

A1 Birtley to Coal House

Scheme Number: TR010031

Applicant's Responses to ExA's Second Written Questions - Appendix 2.0D - Structure Options Report 3 - Allerdene Railway Underbridge

Planning Act 2008

Rule 8(1)(b)

Infrastructure Planning (Examination Procedure Rules) 2010



Infrastructure Planning

Planning Act 2008

**The Infrastructure Planning
(Examination Procedure Rules)
2010**

A1 Birtley to Coal House
Development Consent Order 20[xx]

**Applicant's Response to ExA's Second Written Questions
- Appendix 2.0D - Structure Options Report 3 - Allerdene
Railway Underbridge**

Rule number:	Rule 8(1)(b)
Planning Inspectorate Scheme Reference	TR010031
Application Document Reference	N/A
Author:	A1 Birtley to Coal House Project Team, Highways England

Version	Date	Status of Version
Rev 0	20 April 2020	Application Issue

A1

Birtley to Coal House

Structure Options Report 3

Allerdene Railway Underbridge

Structure no. (/A1//443.00//Q)

STKEY 8880

A1 BIRTLEY TO COAL HOUSE
PCF STAGE 3 (PRELIMINARY DESIGN)
STRUCTURE OPTIONS REPORT 3
ALLERDENE RAILWAY UNDERBRIDGE

Highways England

Date: March 2018

Project no:

HE PIN: 551462
WSP Ref: 70015226

Prepared for:

Highways England

Lateral
8 City Walk
Leeds
West Yorkshire
LS11 9AT



Three White Rose Office Park
Millshaw Park Lane
Leeds
LS11 0DL

Tel: +44 (0) 113 395 6200
Fax: +44 (0) 113 395 6201
www.wsp.com

QUALITY MANAGEMENT

ISSUE/REVISION SUITABILITY	FIRST ISSUE P01	REVISION 1	REVISION 2	REVISION 3
Remarks	Issued for Comments	Final Issue - Incorporating Highways England comments	Final Issue – End of Stage 3 – Preliminary Design	
Date	08/05/2017	09/06/2017	08/03/2018	
Prepared by	Hitan Mistry	Hitan Mistry	Giovanna Brunetti Barchetta	
Signature	HM	HM	GBB	
Checked by	Steve Denton	Steve Denton	Hitan Mistry	
Signature	SD	SD	HM	
Authorised by	Nigel Rawcliffe	Nigel Rawcliffe	Nigel Rawcliffe	
Signature	NR	NR	NR	
Project number	PIN: 551462 WSP ref: 70015226			
Report number	HE551462-WSP-SBR-BCH-RP-S-1700-048			
File reference	HE551462-WSP-SBR-BCH-RP-S-1700-048_P03			

PRODUCTION TEAM

CLIENT (HIGHWAYS ENGLAND)

Major Projects Senior Responsible
Owner Patrick Moran

Major Projects Programme Manager Patrick Moran

Major Projects Project Manager Nicola Wilkes

RIS Area 14 Coordinator Graeme Watt

Senior User Representative Simon Brown

WSP

RIS Area 14 Programme Director Darren Powell

RIS Area 14 Programme Manager TBA

Project Director Darren Powell

Project Manager Nigel Rawcliffe

TABLE OF CONTENTS

EXECUTIVE SUMMARY	8
1. INTRODUCTION.....	10
2. EXISTING STRUCTURE	13
3. ALIGNMENT OPTIONS.....	16
4. GROUND INVESTIGATION	19
5. STATUTORY UNDERTAKERS INFORMATION.....	22
6. INITIAL STRUCTURAL FORMS CONSIDERED	25
7. LIAISON WITH KEY INTERNAL AND EXTERNAL STAKEHOLDERS	32
8. REFINEMENTS TO THE PREFERRED STRUCTURAL FORM	35
9. CONCLUSION & RECOMMENDATION	42

APPENDICES

A P P E N D I X A INDICATIVE SCHEMATIC PLANS

APPENDIX A-1 HIGHWAY ALIGNMENT OPTION 1

APPENDIX A-2 HIGHWAY ALIGNMENT OPTION 2

A P P E N D I X B LOCATION PLAN

APPENDIX B-1 ALLERDENE BRIDGE LOCATION PLAN

A P P E N D I X C ALLERDENE BRIDGE EXISTING AS BUILT RECORDS

APPENDIX C-1 EXISTING GA & STRENGTHENING DETAILS

A P P E N D I X D A1BSCH GENERAL SERVICES PLANS (SHEET 1 OF 3 CONTAINS ALLERDENE BRIDGE)

APPENDIX D-1 A1B2CH SERVICES PLANS

A P P E N D I X E MINUTES TO MEETING – NGN/WSP PB

APPENDIX E-1 MINUTES TO MEETING - NGN/WSP PB

A P P E N D I X F NWR OUTLINE REQUIREMENTS – THIRD PARTY WORKS

APPENDIX F-1 NWR OUTLINE REQUIREMENTS – THIRD PARTY WORKS

A P P E N D I X G OUTLINE GENERAL ARRANGEMENT DRAWINGS – STRUCTURE OPTIONS

APPENDIX G-1 ST001 NETWORK ARCH GA

APPENDIX G-2 ST002 SINGLE SPAN INTEGRAL BRIDGE GA

APPENDIX G-3 ST003 TWO SPAN CONTINUOUS BRIDGE GA

APPENDIX G-4 ST004 THREE SPAN CONTINUOUS BRIDGE GA

A P P E N D I X H COSTAIN BUILDABILITY REVIEW – OPTIONS ST001- ST004

APPENDIX H-1 COSTAIN BUILDABILITY REVIEW – OPTIONS ST001-ST004

A P P E N D I X I

MEETING MINUTES – NWR/HE/WSP PB

APPENDIX I-1 MEETING MINUTES – NWR/HE/WSP PB

A P P E N D I X J RESPONSE TO AONE + ALLERDENE BRIDGE QUERIES

APPENDIX J-1 MEETING MINUTES – NWR/HE/WSP PB

A P P E N D I X K STANTON CROSS BRIDGE DATA SHEET

APPENDIX K-1 STANTON CROSS BRIDGE DATA SHEET

A P P E N D I X L DESIGNERS RISK ASSESSMENT – ALLERDENE BRIDGE

APPENDIX L-1 DESIGNERS RISK ASSESSMENT – ALLERDENE BRIDGE

A P P E N D I X M INDICATIVE CONSTRUCTION SEQUENCE

APPENDIX M-1 INDICATIVE CONSTRUCTION SEQUENCE

A P P E N D I X N UPDATED INTEGRAL BRIDGE GAS

APPENDIX N-1 INTEGRAL BRIDGE OPTION (A) – GIRDER DEPTH 2.0M

APPENDIX N-2 INTEGRAL BRIDGE OPTION (B) – GIRDER DEPTH 2.1M

A P P E N D I X O EXISTING ALLERDENE BRIDGE – MAINTENANCE EXPENDITURE

APPENDIX O-1 ALLERDENE BRIDGE MAINTENANCE EXPEDITURE

APPENDIX O-2 INTEGRAL BRIDGE OPTION (B) – GIRDER DEPTH 2.1M

A P P E N D I X P KEY CORRESPONDENCE

APPENDIX P-1 CLOSE OUT COMMENTS BETWEEN HE / WSP

EXECUTIVE SUMMARY

In December 2014, the government issued its Road Investment Strategy, which included a commitment to upgrade the stretch of the A1 between J65 Birtley and J67 Coalhouse. The improvement will take the form of a dual three lane rural all-purpose road between J65 (Birtley) and J67 (Coal House) with a lane gain / lane drop between each junction (both northbound and southbound).

The existing Allerdene Railway Bridge has a number of inherent design/construction deficiencies which cannot be easily resolved due to the complex structural form (half joints) and site constraints. The intention is the existing Allerdene Bridge shall be replaced as part of the A1 Birtley to Coalhouse Improvement scheme.

Three options were identified at PCF Stage 1 (Option Identification), maintaining the same alignment and cross section between J66 (Eighton Lodge) and J65 (Birtley), where widening of existing structures is possible. However, it has been determined that online widening is not possible at Allerdene Railway Bridge. Existing maintenance issues dictate that the existing structure has to be replaced. The two proposed options are:

- Option 1A (previously referred to as Option 2) Replacement of Allerdene Railway Bridge as close as possible to the existing structure to enable the retention of Coal House interchange.
- Option 1B (previously referred to as Option 1) Widening/Replacement of Allerdene Railway Bridge with a wider structure in its existing location and retention of Coal House Interchange and the existing alignment as far as is possible.

The successful delivery of the scheme is dependent on the works to replace the existing Allerdene Bridge with a new offline structure.

This Structures Option Report has been prepared to assess the constraints/challenges associated with the replacement of the existing Allerdene Railway Bridge. The report was brought forward from Stage 3 to Stage 2 to provide more assurance about the scheme and ensure any potential issues are identified/ addressed before they have a significant impact.

The report has been drafted to reflect the logical sequence and development of the study. Details within this report shows how the study evolved prior to a recommendation being provided on the final proposal for the replacement of Allerdene Bridge.

The study has shown Option 1A to be the preferred route based on programme and cost benefits in addition to improved buildability.

Various structural forms and span configurations were assessed for the off-line replacement of Allerdene Bridge. The preliminary analysis has demonstrated that a 62m integral bridge form is a viable option for the off-line replacement of Allerdene Bridge. An integral bridge would provide a robust cost effective bridge solution with significant long-term maintenance benefits.

The estimated construction cost of a 62m integral bridge option would be £12-13 million.

Further liaison with key stakeholders such as Statutory Undertakers/Network Rail and the HE Abnormal load team is required to formally approve and sign off the integral bridge proposal for further development at detailed design.

Based on the studies to date, it is recommended that the off-line replacement of Allerdene Bridge be further developed.

The following should be undertaken to further validate the integral bridge recommendation made in this report.

- Further Liaison with Statutory Undertakers – confirm diversion to undertake the works
- Further Liaison with Network Rail including submission of draft technical approval documents (AIP/Form A for the integral bridge design and OLE works) for formal approval.
- Liaison with the HE Abnormal Load team to confirm abnormal loading design requirements prior to detailed design.

The above would provide clarity on the constraints to be considered for the off-line bridge design and ensure abortive works are negated at detailed design stage whilst satisfying the Highways England Client Scheme Requirements.

1. INTRODUCTION

1.1 SCHEME OVERVIEW

The scheme forms part of the Newcastle Gateshead Western Bypass (NGWB) which is located on the A1 between J65 (Birtley) and J80 (Seaton Burn). It is part of Highways England's strategic road network serving the metropolitan area of Tyne and Wear.

The scheme is located between J65 (Birtley) and J67 (Coal House) and is approximately 4.2km in length. The existing carriageways comprise:

- Southbound: Two lanes between J67 (Coal House) and J66 (Eighton Lodge) with an additional climbing lane between Smithy Lane Overbridge and J66 (Eighton Lodge) and three lanes between J66 (Eighton Lodge) and J65 (Birtley). The existing speed limit is 50 mph between J67 (Coal House) and Smithy Lane Overbridge and 70 mph thereafter.
- Northbound: Two lanes with a lane gain/lane drop between J65 (Birtley) and J66 (Eighton Lodge) and two lanes between J66 (Eighton Lodge) and J67 (Coal House). The existing speed limit is 50 mph throughout.



Figure 1 - Scheme Location Plan

A Feasibility Study was undertaken in 2014 to determine the existing issues on the route and prioritise the sections which most urgently need attention. A Strategic Outline Business Case (SOBC) was produced for the options which performed well at the Options Assessment Stage, as follows:

- J65 (Birtley) - J67 (Coal House) A1 Birtley to Coal House (including Allerdene Railway Bridge)
- J74 (Scotswood) - J79 (North Brunton) A1 Scotswood to North Brunton

Both schemes were announced in the Autumn Statement in December 2014 as schemes that should be taken forward into the Roads Investment Strategy (RIS), for delivery in the current roads period. The completion of the Feasibility Study concluded PCF Stage 0 (Strategy, Shaping and Prioritisation) for both schemes.

1.2 PROGRESS TO DATE – PCF STAGES

PCF Stage 1 (Option Identification) concluded in April 2016 and the A1 Birtley to Coal House scheme has now progressed to PCF Stage 2 (Option Selection).

Based on the current traffic data, the improvement will take the form of a dual three lane rural all-purpose road between J65 (Birtley) and J67 (Coal House) with a lane gain / lane drop between each junction (both northbound and southbound). The carriageway cross section will be to standard in accordance with TD 27/05.

Three options were identified at PCF Stage 1 (Option Identification) with the same alignment and cross section between J66 (Eighton Lodge) and J65 (Birtley), where widening of existing structures is possible. However, it has been determined that online widening is not possible at Allerdene Railway Bridge. Existing maintenance issues dictate that the existing structure has to be replaced. The three proposed options were:

- Option 1a (previously referred to as Option 2) Replacement of Allerdene Railway Bridge as close as possible to the existing structure to enable the retention of Coal House interchange.
- Option 1b (previously referred to as Option 1) Widening/Replacement of Allerdene Railway Bridge with a wider structure in its existing location and retention of Coal House Interchange and the existing alignment as far as is possible.
- Option 3 Replacement of Allerdene Railway Bridge approximately 150m south of the existing location with an improved mainline alignment and new interchange at Coal House.

PCF Stage 1 (Option Identification) concluded that Option 3 should be omitted from further assessment as the scheme is deemed unaffordable after an Order of Magnitude was calculated for the option in PCF Stage 1 (Option Identification).

The costs for Option 3 were significantly higher than option 1a and 1b, in addition more land would be required and there would be a greater impact on the surrounding environment, however the benefits achieved on all the options would be very similar. Therefore option 3 was deemed to not offer good value for money and so was discounted.

Refer to Appendix A for schematic plans for route Option 1A and 1B.

1.3 REPORT OBJECTIVES

The successful delivery of the scheme is dependent on the works to replace the existing Allerdene Bridge with a new offline structure.

This Structures Option Report has been prepared to assess the constraints/challenges associated with the replacement of the existing Allerdene Railway Bridge. The report has been brought forward from Stage 3 to Stage 2 to provide more assurance about the scheme and ensure any potential issues are identified/ addressed before they have a significant impact. One of the key issues addressed as part of this report is early liaison with Network Rail to identify potential constraints that would impact the structural form and buildability.

The report has been drafted to reflect the logical sequence and development of the study. Details within the report shows how the study evolved prior to a recommendation being provided on the final proposal for the replacement of Allerdene Bridge.

Upon completion and sign off, this report shall provide Highways England with sufficient information/justification for seeking approval/funding to progress the works as the scheme progresses.

2. EXISTING STRUCTURE

2.1 GENERAL DESCRIPTION

Allerdene Railway Bridge is located on the southern outskirts of Gateshead at OS Grid Reference 425480E, 558489N. It carries the A1 dual two lane all-purpose trunk road over the London to Edinburgh East Coast Main Line (ECML) high speed railway. Refer to Appendix B for plans showing the location of Allerdene Bridge relative to adjacent infrastructure.

The bridge was constructed at a slew of 45 degrees to the railway and comprises two parallel three span structures, each carrying two lanes of traffic, supported on bank seats and leaf piers common to both superstructures.

The total length of the bridge is approximately 80m consisting of a central railway span of 44m and two side spans of 18m.

The two side spans are formed from reinforced concrete decks supported on cast in-situ reinforced concrete beams which cantilever over the reinforced concrete leaf piers at the railway boundary.

The central (railway) span consists of a reinforced concrete deck acting compositely with weathering steel girders. The internal steel girders are in the form of fabricated I sections while the external girders comprise fabricated box sections.

The centre span of the bridge is simply supported over the railway by half joint nibs protruding from the lower halves of the ends of the reinforced concrete side span beam cantilevers. This form of deck is commonly referred to as a suspended span.

The deck is supported on mechanical bearings over the bank seats and piers. The suspended central span is supported on mechanical bearings at the concrete half joints. The purpose of the bridge bearings is to aid the transfer of loads and movements from the deck to the substructure and foundations.

Refer to the general arrangement drawing in Appendix C for details.

2.2 DESIGN & CONSTRUCTION ISSUES

The bridge was constructed circa 1974. As works were nearing completion cracks were identified at the half joints that concerned the bridge promoters at the time, Durham County Council, to the extent that they designed and installed retrospective strengthening works as a matter of urgency.

The half joints to the reinforced concrete cantilever spans were strengthened by the installation of secondary structural steel members in and around the side spans beams (encased in concrete). The objective of the steelwork was to relieve the imposed load on the existing concrete half joints and provide an alternative load path into the beams and back into the substructure and foundations. Refer to Appendix C for details of the strengthening works.

Further special inspections and studies over the last 10 years have indicated potential workmanship/detailing issues that have resulted in deficiencies in the reinforcement design and detailing of the half joints.

Surveys by the Aone+ MAC, circa April 2015, indicate further deficiencies in the cover to reinforcement and the deck thickness (reduced in comparison to the thickness shown on archive drawings).

In addition to the above, there are also issues relating to the existing geometric highway design. The speed limit on the A1 Allerdene Railway Bridge has been reduced from 70mph to 50mph circa 2010. The curvature of the existing A1 over Allerdene Bridge is approximately 675m and the current super elevation is approximately 3.33%. Based on current standards this combination of values shows the current alignment is not fully to standard for the design speed of 85kph (50mph).

2.3 CURRENT LOAD BEARING CAPACITY

The bridge was last assessed in 2013 and was certified as having the following capacity.

- Able to sustain Dead and Superimposed Loading
- Able to sustain 40T Assessment Live Load (ALL) in accordance with BD21/01

The bridge has no abnormal load capacity and therefore all abnormal load movements are currently diverted to alternative routes to avoid passing over the bridge. The restriction on abnormal loads movement is currently causing problems to the local network further adding to the congestion issues in this area.

Monitoring regime in accordance with BD79/06 is currently being implemented on the bridge.

2.4 EXISTING MAINTENANCE ISSUES

The structural form and construction issues have also contributed to some of the defects/maintenance issues associated with the existing structure, details of which are discussed below.

HALF JOINTS

Half-joints such as those at Allerdene were introduced into bridge decks as a means of simplifying design and construction operations. However this form of joint is vulnerable to deterioration in the event of deck expansion joint failure, where chloride rich (carriageway de-icing salts) seepage through the joint can cause concrete deterioration and corrosion of the reinforcement. Loss of reinforcement section through corrosion and associated concrete spalling can induce higher stresses and significantly reduce the safety margins expected of serviceable structures. Half joints are a particular concern because they are not easily accessible for inspection or maintenance.

In the case of Allerdene, the risk associated with the deterioration of the half joint is mitigated by the retrospective steel work strengthening to the joints which was installed during construction. To ensure the safe operation of the bridge, it is critical that the structural integrity and condition of the steelwork strengthening to the half joints is maintained.

The secondary steelwork sections supporting half joints are encased in concrete which restricts access for inspection and maintenance. This gives rise to an increased risk associated with the unknown condition/integrity of these hidden critical structural elements.

CONCRETE DEFECTS

Extensive concrete investigation and inspection works have been undertaken over the past 10 years on the approach and central span deck elements. The results showed a particularly

prominent area of delamination/spalling and corrosion to the deck reinforcement of the central (railway) span deck. Repair works have been ongoing over the last 10 years.

Liaison with the Aone+ MAC highlighted that a crash deck has been installed under both the central span decks to carry out the repair works and to prevent materials falling on the railway line. This minimises the safety risk associated with falling debris and the cost implication associated with disruption to the rail service.

BEARING DEFECTS

The detailed investigation of the bearings in 2010 indicated that all the bearings suffer from moderate to extremely severe corrosion. The extent of the corrosion suggests the bearings may not be functioning in line with their design capacity.

The non-movement of the bearings is most likely inducing stresses into the adjacent structural components and is possibly responsible for some of the structural cracking and concrete failures at these locations.

MAINTENANCE COST TO DATE

In the last ten years approximately £8million to £10 million pounds has been expended in maintenance works, related studies and surveys. Refer to Appendix O for details.

As the residual life of the structure further reduces, it is anticipated that the maintenance cost to keep the bridge serviceable will only increase.

The access issues and constraints associated with limiting the disruption to both traffic over the bridge and railway operation under the bridge, results in a significant increase in the cost/time and complexity associated with critical maintenance work.

2.5 APPROVAL TO REPLACE THE EXISTING ALLERDENE BRIDGE

The review of previous studies to Allerdene Railway Bridge has shown the existing structure to have a number of inherent design/construction deficiencies which cannot be easily resolved due to the complex structural form (half joints) and site constraints. The maintenance costs to keep the structure in service are now considerable and will most likely increase as the residual life of the structure reduces.

Liaison with the Highways England Operations Directorate has confirmed that more money is to be spent by 2023/24 to maintain the existing structure if it is not replaced.

Based on the above it has been agreed that Allerdene Bridge should be replaced as part of any long term A1 Birtley to Coalhouse improvement scheme, irrespective of the preferred route option.

3. ALIGNMENT OPTIONS

3.1 EXISTING A1 ALIGNMENT

The existing A1 crosses the East Coast Mainline via the Allerdene Bridge. At this location the existing A1 is a 2 lane All-Purpose Dual Carriageway and subject to a 50mph speed limit. The alignment carries an approximate 675m radii right hand bend (from west to east) which is broadly comparable with the speed limit.

There are several constraints due to Highways England and Network Rail requirements, and features in the vicinity of the existing Allerdene Bridge, which constrain any highway re-alignment associated with a replacement Allerdene Bridge. These are:

- Existing Allerdene Bridge – As the demolition of the existing Allerdene Bridge is expected to be complex, if the bridge is required to be demolished prior to the completion of the proposed New Allerdene Bridge and A1, this would incur a reasonable delay and increased risk of further delay to the opening of the scheme.
- East Coast Mainline requirements – Network Rail's Horizontal and Vertical Clearance requirements for the East Coast Mainline constrain the position and alignment of the replacement Allerdene Bridge.
- Kingsway Viaduct – Comprises a six span steel composite structure approximately 400m west of the existing Allerdene Bridge. This carries the A1 over the Junction 67 (Coal House) roundabout. Any works required to the viaduct beyond at-grade asymmetric widening are likely to incur significant additional cost; this constrains the alignment on approach to the replacement Allerdene Bridge.
- Operational requirements during construction – It is a Highways England requirement that the A1 should not be reduced below 2 lanes northbound and southbound, throughout construction during peak hours.
- Gas Distribution Plant – A gas distribution plant is located to the northwest of the existing Allerdene Bridge, adjacent to the A1. Land take in this location which requires the demolition and reconstruction of part or all of the gas distribution plant is likely to incur significant additional cost. Impacts of services are discussed in more detail within Section 4 of the report.
- Smithy Lane Overbridge – Smithy Lane Overbridge is an existing 3 span structure approximately 300m southeast of the existing Allerdene Bridge, which carries Smithy Lane over the existing A1. Any amendments to the bridge are likely to require full demolition and reconstruction and incur a reasonable cost; this constrains the alignment on approach to the replacement Allerdene Bridge.
- Junction 67 (Coal House) west facing slips – The Junction 67 (Coal House) southbound merge and northbound diverge are located to the west of, and in close proximity to, the existing Allerdene Bridge. Realignment of the mainline may result in the slips being unable to connect into the existing Junction 67 (Coal House) roundabout, which would require an elongation to the roundabout. This is likely to require diversions of existing Statutory Undertaker Equipment, extension of existing culverts, and incur a reasonable cost.

3.2 PROPOSED ALIGNMENT OPTIONS

Two options have been developed which provide differing alignments for the proposed replacement of Allerdene Bridge over the East Coast Mainline. A number of design parameters common to both options in this location, are as follows:

- 85kph design speed
- 50mph speed limit
- Urban All-Purpose Dual Carriageway cross section; and
- 3 lanes plus lane gain / drop for in both the northbound and southbound carriageways
- Minimise impact on the adjacent structures as far as reasonably practical

The Options are described in more detail below.

3.3 ALIGNMENT OPTION 1A (PREVIOUSLY REFERRED TO AS OPTION 2)

Option 2 proposes a realignment of the A1 to the south of the existing Allerdene Bridge, between Junction 67 (Coal House) and Smithy Lane Overbridge. This alignment allows for a fully offline Allerdene Bridge replacement.

The option's performance, in terms of the identified constraints, is as follows:

- Existing Allerdene Bridge – The highway alignment and proposed Allerdene Bridge could be constructed without requiring demolition of the existing Allerdene Bridge.
- Kingsway Viaduct – The highway alignment connects horizontally and vertically into the existing alignment prior to Kingsway Viaduct which would only require at grade asymmetric widening.
- Operational requirements during construction – As the bridge can be constructed off-line, the existing A1 can remain open over the existing Allerdene Bridge until traffic can be re-routed onto the proposed Allerdene Bridge.
- Gas Distribution Plant – The highway alignment is proposed off-line to the south and would not require land take from the gas distribution plant.
- Smithy Lane Overbridge – The highway alignment fits horizontally within the existing Smithy Lane Overbridge, and is close to the existing vertical. However, further information and design development are required to confirm whether Smithy Lane Overbridge can be retained without amendment.
- Junction 67 (Coal House) west facing slips – The requirement of works to the Junction 67 (Coal House) roundabout is subject to on-going design development.

3.4 ALIGNMENT OPTION 1B (PREVIOUSLY REFERRED TO AS OPTION 1)

Option 1 proposes an on-line replacement of the A1 and existing Allerdene Bridge, between Junction 67 (Coal House) and Smithy Lane Overbridge. This alignment would require temporary offline bridges.

The option's performance, in terms of the identified constraints, is as follows:

- Existing Allerdene Bridge – The highway alignment would require the demolition of the existing Allerdene Bridge to allow construction of the replacement Allerdene Bridge.
- Kingsway Viaduct – The highway alignment connects horizontally and vertically into the existing alignment prior to Kingsway Viaduct which would only require at-grade asymmetric widening.
- Operational requirements during construction – The construction and subsequent removal of temporary bridges would be required to maintain the required levels of traffic on the A1 during the on-line replacement works.
- Gas Distribution Plant – The highway alignment would require land take from the gas distribution plant and would require its demolition and reconstruction.
- Smithy Lane Overbridge – The highway alignment fits horizontally within the existing Smithy Lane Overbridge, and is close to the existing vertical. However further information and design development is required to confirm whether Smithy Lane Overbridge can be retained without amendment.
- Junction 67 (Coal House) west facing slips – The requirement of works to the Junction 67 (Coal House) roundabout is subject to on-going design development.

3.5 PREFERRED ALIGNMENT

The assessment to date shows Option 1A being the preferred route. Reasons favouring this option include;

- De-risking the programme – Based on the demolition of the existing structure no longer being on the critical path the risks associated with NWR interface and possession work are significantly reduced.
- Improved buildability – Sufficient working room can be provided during the construction of the new Allerdene Bridge with improved maintenance benefits incorporated into the design.
- Reduced disruption and impact to traffic - Provision of two lanes of traffic in both directions during construction can be more readily maintained with Option 1A.
- Reduce complex temporary works – The requirements for the installation of complex temporary bridges/retaining structures to maintain the required level of traffic is eliminated.
- Reduced Cost/Programme – High level estimates indicate the overall cost/programme of the scheme would be significantly reduced for Option 1A in comparison to Option 1B.

From this point onwards, all discussion regarding the replacement of Allerdene Bridge is based on Option 1A being the preferred highway alignment.

Details of the geotechnical and statutory services impacting the Offline Allerdene bridge replacement options are discussed in Sections 4 and 5 of this report.

4. GROUND INVESTIGATION

4.1 OVERVIEW OF EXISTING GROUND CONDITIONS

A Geotechnical Design Report is not yet available for the project; this will be prepared defining suitable parameters for the design and acceptable foundations following undertaking of a comprehensive ground investigation at the site. The preliminary choice of foundation solution has been considered appropriate based on the records and findings local to the site, taken from the Preliminary Sources Study Report (PSSR) for the wider Birtley to Coal House Scheme (HA544664-WSP-HGT-S01-RP-GE-0600-P-01).

Historical ground investigation data from British Geological Survey and HA GDMS is available within the vicinity of the proposed bridge locations, and is presented within PSSR. With reference to the PSSR, the following ground conditions are anticipated at the bridge location:

- Made ground: Primarily comprising the existing road earthworks; over,
- Glaciolacustrine deposits: Primarily comprising laminated clays, approximately 25 to 30m thick; over,
- Weathered rock: Primarily comprising silty sand, approximately 5 to 10m thick; over,
- Pennine middle coal measures: Comprising sandstone, mudstone, siltstone, and coal.

No ground investigation records are available post construction of the existing bridge, and the depth and composition of the anticipated Made Ground is unknown at this stage.

Two coal seams are recorded as being worked at shallow depth beneath the site, being the Brass Thill and Hutton seams at approximately 40 to 50, and 55 to 65m below ground level, respectively. It is not known whether any stabilisation measures were undertaken to these seams during construction of the existing road / bridge at the site.

Groundwater is not recorded in available historical borehole records in the vicinity of the proposed bridge; however, potential perched and shallow groundwaters are recorded for the wider site, and are anticipated within Made Ground and Glaciolacustrine Deposits.

4.2 RISKS ASSOCIATED WITH FOUNDATION WORKS

The geotechnical risks for the wider site are presented within the PSSR report. These risks have been reviewed and further assessed in the 'Live' Project Risk Registers (Highways England Risk Register v12, August 2015), as discussed with and presented to Highways England. Pertinent geotechnical risks in relation to the proposed bridge foundations are summarised below:

RISK CAUSE	RISK EVENT	PRIMARY RISK IMPACT	RISK RATING*
Engineering Properties of the Ground	There is a risk that the ground model, and the behaviour of such to the proposed works, is different (worse) from that assumed at this	Construction delays and remedial design requirements, and potential cost and programme implications.	Medium

RISK CAUSE	RISK EVENT	PRIMARY RISK IMPACT	RISK RATING*
	stage.		
Groundwater	There is a risk that the groundwater model is different (worse) from that assumed at this stage.		Medium
Contaminated Soils	There is a risk that the assessment of contaminated soils undertaken at this stage is not accurate.		Medium
Unexploded Ordnance	There is a risk that the existing earthworks at the site are not as stable as assumed at this stage.	Construction delays and requirement for safe deactivation / disposal.	Low
Historical Mining	There is a risk that historical mine working collapse may affect the proposed works.	Construction and operational collapse of the running surface / structures.	High

* Current assessed level based on Highways England PID and Risk Matrix (v12, August 2015).

Table 4.2 Geotechnical Risk

4.3 DETAILS OF ADDITIONAL GROUND INVESTIGATION REQUIRED TO INFORM THE DETAILED DESIGN PROCESS

The PSSR and accompanying Annex A document (HA544664-WSP-HGT-S01-RP-GE-0600-A-02) provides a description of the proposed ground investigation required to inform the detailed design of an entirely off-line road alignment option (Option 3). This alignment option is no longer being considered; however the principles of the investigation remain the same. The proposed ground investigation required to inform the detailed design process is as follows:

- Cable percussion boreholes to rock head to identify ground conditions within the superficial deposits and confirm rockhead levels;
- Rotary cored boreholes to approx. 9m below rockhead to determine rock quality and strength; and,
- Rotary open hole boreholes to approx. 30m below rockhead to confirm the presence of coal seams and historical mining.

Each of the above ground investigation methodologies may be undertaken at the same location / exploratory hole through follow-on methods, i.e. Cable percussion to rockhead; follow-on with rotary core from rockhead to 9m below rockhead; and follow-on with open hole to proposed borehole depth.

It is considered likely that between 11 (eleven) and 15 (fifteen) boreholes shall be required for the development of the design. The final number of boreholes shall be dependent on the proposed Bridge Option taken forward; however (in line with Annex B of BS EN 1997-2) it is anticipated that the following shall be adopted:

- For the approach embankments: boreholes at a spacing of one per 50 to 100m; and,

- For the bridge structure: Minimum two boreholes per foundation.

The ground investigation shall be reported in a Ground Investigation Report (in line with HD 22/08).

At this stage, and dependent on the Bridge Option taken forward, the following significant (i.e. greater than normally encountered during this type of work) potential constraints / restrictions have been identified:

- Investigation works are likely to be undertaken on or immediately adjacent to a live highway and shall therefore require road space bookings and traffic management;
- Investigation works may be required to be undertaken within Network Rail land and shall therefore require possession booking and suitable safe systems of work to be put in place; and,
- Investigation works are likely to come into close proximity to buried and overhead services and, as such, detailed pre-works survey and management of services shall be required.

4.4 REVIEW OF FOUNDATION REQUIREMENTS

The final bridge foundations shall be determined through assessment of the bearing capacity of the founding materials (influenced by the ultimate limit state) and settlement analysis of the foundations (influenced by serviceability limit state).

Initial assessment indicates that shallow foundations are unlikely to be feasible for any of the Bridge Options considered (bearing capacity requirements too high for the assumed ground). It is anticipated that deep, piled, solution shall be required irrespective of the structural form.

Detailed design of any piled solution is likely to be the responsibility of the specialist Piling Contractor (and reported within a Geotechnical Design Report in line with HA 22/08). However, for the benefit of this report an initial feasibility assessment has been undertaken.

Given the potential for loose / soft Made Ground and near surface natural deposits, and the sensitivity of the existing structures at the site to ground movements (existing Allerdene Bridge and the Network Rail infrastructure), it is considered likely that a reinforced concrete bored pile solution will be most suitable for the site. However the use of other piling techniques may also be appropriate for the scheme and may be proposed by the Contractor.

Preliminary assessment of individual pile capacities for various pile diameters and depths indicates that an appropriate pile design would be developed with piles bearing on / into rockhead (socketed to provide fixity). Piles bearing on rock are anticipated to demonstrate minimal (less than 15mm) total settlements for each pile.

For any proposed foundation solution the presence of historical mining at the site is required to be determined, and the risk of collapse of such workings affecting the site appropriately mitigated against (in line with BD 10/97). If encountered / suspected to be present beneath the site, shallow historical mining is likely to be most appropriately mitigated / remediated through a drill and bulk grouting solution. It may be considered appropriate to extend any pile through remediated mined coal seams / broken ground if these are proven to be present near to rockhead / proposed pile toe level.

5. STATUTORY UNDERTAKERS INFORMATION

5.1 GENERAL

C3 budget estimates and consultation has been progressed to date for the scheme. Full details of the C3 consultation process is recorded in the following report, C3 Budget Estimate HA551462-WSP-GEN-BCH-RP-D-0100-012-S2-P4.0.

The table below, extracted from the C3 Budget Estimate report, lists the existing statutory undertaker's equipment within the vicinity of the proposed works for the offline replacement of Allerdene Bridge. Refer to Appendix D for plans showing the location of services tabulated below.

STATUTORY UNDERTAKER	LOCATION REF. NO	EXISTING APPARATUS LOCATION	PROPOSED DIVERSIONARY WORKS	BUDGET ESTIMATES (EX. VAT)*	LEAD TIME*	COMMENTS
British Tele-communications	BT104	Allerdene Railway Bridge. Runs under the bridge along the East Coast Mainline	No existing records could be abandoned	£160,875 (ex. VAT)	3 months	
Northern Power Grid	NP106	Allerdene Railway Bridge. Runs under bridge along the East Coast Mainline	Divert the existing HV underground and associated pilot cables adjacent to East Coast Main Line to allow the construction of the new A1 bridge above	£110,000 (ex. VAT)		
Northern Power Grid	NP107	South of Allerdene Railway Bridge. Crosses carriageway just South of bridge				
Northern Gas	NG104	South of J67 (Coal House). Crosses SB entry slip, main carriageway and NB exit slip				
Northern Gas	NG107	South of J67 (Coal House). Crosses carriageway and also runs long the verge of the NB exit slip		£77,834.82 (ex. VAT)	14 weeks	

A1 Birtley to Coal House Improvement Scheme
PCF Stage 3 – Structure Options Report 3: Allerdene Railway Underbridge

STATUTORY UNDERTAKER	LOCATION REF. NO	EXISTING APPARATUS LOCATION	PROPOSED DIVERSIONARY WORKS	BUDGET ESTIMATES (EX. VAT)*	LEAD TIME*	COMMENTS
Northern Gas	NG108	South of J67 (Coal House). Crosses carriageway and also runs long the verge of the NB exit slip				
Further Works and Budget Indication Received From Northern Gas Networks (April 2017)						
	NG111	Pressure Reduction Station (PRS) located northwest of Allerdene Railway Bridge.	Option 1a – Abandon three mains from PRS which cross the A1 and lay new mains to fit new highway alignment. Existing PRS is to be retained.	£4,655,000 (ex. VAT)	36 weeks	NGN Option 1a
	NG111	Pressure Reduction Station (PRS) located northwest of Allerdene Railway Bridge.	Option 1b – Abandon PRS and the three mains which cross the A1. Relocate PRS on land south of the A1 and lay one medium pressure main across the A1.	£4,677,000 (ex. VAT)	52 weeks	NGN Option 1b
Instalcom	IC101	Allerdene Railway Bridge. Apparatus runs along the East Coast Mainline under the existing bridge	Apparatus is very unlikely to be affected as located below the existing and proposed over-bridges	£60,000 (ex. VAT)		Survey to verify apparatus location. Review in detail at C4 stage
Virgin Media	V103	Allerdene Railway Bridge. Apparatus runs under the bridge along the East Coast Mainline	Unaffected. Cables within rail network.	£167,028.22 (ex. VAT)	26 weeks for completion	Virgin Media lease fibre optics within a third party (Global Crossing) cable.
Vodafone	VF101	Allerdene Railway Bridge. Apparatus under the bridge running along the East Coast Mainline		£4,963 (ex. VAT)	6 weeks	
*Budget Estimates and Lead Times are given for each Statutory Undertaker's Equipment throughout the whole scheme. Table						

Table 5.1 List of Services Impacting the Allerdene Bridge Replacement Works

Advanced discussions are currently ongoing with NGN to confirm the requirements of the diversion works to accommodate the scheme improvement works and also satisfy future aspirations of NGN. Current negotiations indicate all NGN diversion works shall be complete in advance of the start of the main construction works in March 2020. This would ensure no cross over with the NGN infrastructure and proposed Allerdene bridge works. Refer to Appendix E for meeting minutes.

Further consultation will be required with Network Rail to identify track side services that may be impacted by the proposed bridge works. However based on the assumption that the new bridge supports are to be located to ensure a minimum 4.5m lateral clearance from the existing running rail, it is anticipated that the impact on Network Rail based services will be limited.

At this stage it is assumed that all services impacting the proposed bridge replacement works shall be diverted/ protected accordingly to progress the bridge works on site.

6. INITIAL STRUCTURAL FORMS CONSIDERED

6.1 GENERAL

This section provides details of the initial structural forms considered for the offline replacement of Allerdene Bridge.

Below is a list of some of the key constraints/assumptions considered during development of the bridge replacement options:

Network Rail requirements: In the absence of definitive requirements stipulated by Network Rail, the following assumptions were made in accordance with an outline Network Rail guidance paper available during development of this study. Refer to Appendix F for generic NWR new road over rail bridge requirements.

- Headroom – The minimum headroom for any new structure over the railway shall be 5.8m above the track level. This was derived based on interpretation of the following,

“The minimum headroom required is the greater of 5.2m above the existing highest rail or 1.0 above the existing OLE.”

The existing OLE is currently attached to the bridge soffit that is 4.8m above the highest rail. Therefore the minimum headroom was calculated to be 4.8+1.0 to equal 5.8m clearance.

- Lateral clearance – To avoid the designing structures (intermediate supports) for the onerous rail impact loading, a minimum lateral clearance to the nearest running line of 4.5m would be maintained. All structures within 4.5m would need to be designed for rail impact loading.
- Existing overhead line equipment - Assumed would need to be maintained during the works (except during possession working) and OLE apparatus could be attached to the soffit of the new structure similar to the existing condition.
- Works on or near the line (Red Zone Working) - Would only be permitted during pre-arranged NWR possession and isolation works, where the running lines are blocked for train movement. Type of possession works anticipated include:

(1) Rules of the Route Possession (ROR): These are considered to be the least disruptive type of possession available during weekends between 23:00 Saturday night until 06:30 Sunday morning. These require a 12-18 week booking period.

(2) Disruptive Possession: These are a complete weekend closure of the train line to enable continuous access and working over a weekend period. For the ECML this type of possession is generally available over the Christmas period (25th/26th December) and requires up to a 104 week booking period.

- Green zone working (Working adjacent to live rails): Work adjacent to live rails would be permitted on the assumption that a rigid fence is put up between the site of work and nearest open line. The distance between the running line and fence is expected to be a minimum of 3m.
- Future expansion of the railway: Based on experience on other road over rail design schemes, the capacity to increase track capacity in the future was accommodated where possible.

Proposed cross section for the new Allerdene Bridge - The current proposed cross section for the replacement of Allerdene bridge comprises an all-purpose dual 4 lane carriageway with the following dimensions:

- Verge: 2.50m
- Hard strip: 1.00m
- Lane 1: 3.65m
- Lane 2: 3.70m
- Lane 3: 3.70m
- Lane 4: 3.60 m
- Hard strip: 1.00 m
- Central reserve: 2.50 m total

Minimise disruption to the traffic on the existing A1 Highway alignment and Network Rail Infrastructure as much as reasonably practical

Provision of functional/cost effective/easily maintained bridge design solution is required. Iconic aesthetically enhanced land mark structures is assumed to not be a critical requirement due to the scheme budget constraints

Piled foundations would be required to all substructure elements – refer to Section 4 for details

Services would be diverted to accommodate the new bridge construction as required – refer to Section 5 for details

Bridge design loading: New bridge to be designed to sustain the SV196 abnormal load vehicle as defined in UK NA to BS EN 1991-2:2003 (equivalent to 196t abnormal loading)

6.2 STRUCTURAL FORMS

The table below provides details of the structural forms considered for the off-line replacement of Allerdene Bridge.

STRUCTURE REF	STRUCTURE TYPE	DESCRIPTION	DRAWING REF
ST001	Network Arch bridge	134m single span tied arch type structural form where some of the hangers cross each other at least twice. The arches comprise fabricated weathering steel box	Refer to Outline GA Drawing 1 of 4 in Appendix G for details

A1 Birtley to Coal House Improvement Scheme
PCF Stage 3 – Structure Options Report 3: Allerdene Railway Underbridge

STRUCTURE REF	STRUCTURE TYPE	DESCRIPTION	DRAWING REF
		sections with a concrete/steel composite deck. The bridge would comprise 2No. independent arch structures to support the A1 northbound and southbound carriageway respectively. End supports would comprise reinforced concrete bankseats on piled foundations.	
ST002	Single Span Integral Bridge	2No. single span portal structures, each carrying a separate carriageway of the A1. Each portal comprises a steel composite deck acting integrally with reinforced concrete abutment walls on piled foundations. The span of both decks is 58m with a 30deg skew.	Refer to Outline GA Drawing 2 of 4 in Appendix G for details
ST003	2 Span Continuous Structure	Total 83m 2 span structure (main railway span 60m and a side span 33m) with a 45deg skew. Comprise 2No. separate decks carrying the Northbound and Southbound carriageway respectively. Each bridge comprises a steel composite deck with a central reinforced concrete leaf pier and end cantilever abutment walls both supported on piled foundations.	Refer to Outline GA Drawing 3 of 4 in Appendix G for details
ST004	3 Span Continuous Structure	Total 116m 3 span continuous structure (main span 50m and side spans 33m). Comprise 2No. separate decks carrying the Northbound and Southbound carriageway respectively. Each bridge comprises a steel composite deck with reinforced concrete intermediate leaf piers and end cantilever abutment walls supported on piled foundations.	Refer to Outline GA Drawing 3 of 4 in Appendix G for details
The above is based on high level preliminary design calculation and reference to similar type structures on previous schemes.			

Table 6.2 Details of the Structural Forms Considered for the Replacement of Allerdene Bridge

The flared alignment of the rail track configuration at the position of crossing has resulted in consideration being given to skew deck structures for some of the options (ST002/003/004) in order to minimise the overall span and subsequent structure foot print and material costs.

Structure Ref ST001: Network Arch Bridge

ST001 was developed to provide a bridge that completely spans the Network Rail infrastructure thereby limiting the impact of constraints imposed by Network rail during construction and the service life of the bridge. The spanning of the structure beyond the Network Rail boundary would also future proof the bridge in relation to aspirations to increase track capacity at this location. A square span was proposed to simplify the design/construction of long span bridge decks.

The extended span inclines towards a network arch type structure on the basis this would provide a structurally efficient form in comparison with a tied arch with straight forward vertical hangers. Outline details of the Network Arch proposal was based on a recently completed network arch bridge design by WSP|PB for the Northern Hub Ordsall Chord bridge scheme. Refer to the following link for details Ordsall Chord, Manchester: design of the UK's first network arch bridge.

The network arch structure form would also provide a more aesthetically enhanced structure. However due to the size and buildability complexities associated with fabrication/logistics/launching/temporary works etc., the construction and programme implications would be significantly greater in comparison to the other more traditional forms of bridge construction.

Structure Ref ST002: Single Span Integral Bridge

Whilst ST001 was developed to minimise interface with Network rail as much as reasonably practicable, ST002 was developed to provide the shortest optimum span with reduced long term maintenance liabilities. The use of weathering steel girders and integral forms of construction would eliminate all long term major maintenance works (maintenance painting/bearing replacement) that requires track side access.

The reduced overall footprint of the structure combined with the simplified form of construction would also significantly reduce the cost and programme risks during construction.

The reduced span results in the bridge being located within the Network Rail boundary which would require land take negotiations between the HE/Network Rail. In addition there would also be limited clearance for future rail track expansion of the East Coast Mainline.

For further information, the clearance of the proposed new bridge is no worse than what is currently provided by the existing Allerdene Bridge to be replaced. Also to the north of Allerdene Bridge is Chowdene Bank Bridge (HE owned) which in its current form would constrain any proposed rail track expansion.



Figure 1 - Photograph of Chowdene Bank Bridge – located north of the existing Allerdene Bridge

Structure Ref ST003 & 004: Two and Three Span Continuous Structures

These options were developed as a compromise between providing sufficient capacity for future rail track expansion and also limiting the size and complexity of the structure to reduce construction cost.

Continuous forms of construction were proposed to reduce the construction depth and size (weight) of girders thereby reducing material cost and minimising risk associated with the lifting and installation of heavy girders.

ST003 provides an opportunity for rail track expansion to one side only. Alternatively ST004 provides flexibility to increase capacity on both sides via the provision of new tracks through the side spans.

The disadvantage associated with these options is that part of the structure is within Network Rail land requiring land take negotiations. Also the footprint of the structure is bigger compared with STE002 thereby increasing construction cost. The introduction of bearings also increases long term maintenance liability over the service life of the structure.

Some of the key buildability issues associated with the four structure options are recorded in a high level review undertaken by the Support Contractor (Costain). Refer to Appendix H for details.

6.3 ESTIMATED MATERIAL QUANTITIES AND CONSTRUCTION COST

The table below provides a high level comparison of the material quantities and estimated construction cost of the four structural options considered.

	ST001 NETWORK ARCH BRIDGE	ST002 SINGLE SPAN INTEGRAL BRIDGE	ST003 TWO SPAN BRIDGE	ST004 THREE SPAN BRIDGE
Structural Steel (t)	3300	1000	1400	1900
Concrete (m3)	7500	3000	4750	5900
Reinforcement (t)	1500	750	1300	1500
Bearings	8	0	48	64
Cost (£m)*	£40-45	£10-12	£12-15	£15-20

Indicative Construction Cost based on previous similar type schemes. The HE Cost Estimating Team has not been consulted for any costing information for this study.

Table 6.3 Estimated Material Quantities and Construction Cost

6.4 COMPARISON OF STRUCTURAL OPTIONS (ST001-ST004)

The initial structure options (ref ST001-ST004) were compared based on the following;

- Initial Capital Cost
- Programme
- Buildability
- H&S/Risks
- Future Expansion (additional railway tracks)
- NWR land/access requirements
- Sustainability
- WLC/Maintenance

These factors have been scored on a scale of 1-3. A score of 1 represents a poor performance, 2 average and 3 represents the best performance on a given factor.

The option with the highest cumulative score is considered to be the most viable solution.

6.5 RANKING TABLE

The table below sets out the scores attributed to the key factors assessed and compared for each of the options.

	ST001 NETWORK ARCH BRIDGE	ST002 SINGLE SPAN INTEGRAL BRIDGE	ST003 Two SPAN BRIDGE	ST004 THREE SPAN BRIDGE
Initial Capital Cost	1	3	2	1
Programme	1	3	2	1
Buildability	1	3	2	2
H&S/Risk	1	3	2	2
Future Expansion	3	1	2	3
NWR land/access requirement	3	1	1	1
Sustainability	1	3	2	1
WLC/Maintenance	1	3	2	1
Total scores	12	20	15	12

Table 6.5 Ranking Table for Structure Options ST001-ST004

The rationale behind the scoring is as follows:

- Initial Capital Cost – ST002 received the highest score, as this option is considered to be the most cost effective. In comparison ST001 and ST004 received low scores due to the excessive comparative construction cost.
- Construction Programme – ST002 received the highest score, as the estimated construction programme is expected to be shorter in comparison with the other options due to the simplicity of the structural form and the limited overall footprint.
- Buildability – ST002 scored the highest of the four options due to the limited size and the simplicity of the bridge form.
- H&S/Risk – ST002/ST003/ and ST003 scored favourably in comparison with ST001. This was based on the assumption that competent Contractors would be familiar with construction techniques associated with integral or continuous structures. The scale of ST001 and the associated complex launching techniques and temporary works would increase the risks during construction and therefore this option was allocated a low score.
- Future Expansion– ST001 scored the highest as this option can readily accommodate any future expansion of the railway compared with the other options. ST002 scored the lowest as the reduced span limited the opportunity for future track expansion.
- NWR land/access requirements – ST001 scored the highest as there was limited negotiation required with NWR regarding land take/access. ST002-ST004 all received equally low scores as they all require negotiation for land take/access for installation of sub structure/foundations within the NWR boundary.
- Sustainability – ST002 scored the highest due to this option requiring the least amount of material processing. In addition reduced material quantities would also result in reduced haulage and CO2 emissions.

- WLC/Maintenance – ST002 scored the highest as an integral structural form with weathering steel girders would have the least long term maintenance liabilities. ST001 was allocated a low score due the complex inspection/maintenance regime associated with the hangers. In addition bearings would need to be replaced during the structure service life. ST002/ST003 also has greater maintenance liabilities in comparison with ST002 due to the extensive number of joints/bearings needing maintenance during the bridge service life.

Based on the scores above, ST002; Single Span Integral Bridge is considered the most favourable option for the replacement of Allerdene Bridge. Formal approval of the structural form, assumed working constraints and proposed clearances is required from Network rail prior to development at detailed design.

Liaison with NWR and other key internal stakeholders (HE Abnormal Load team/Aone+) is currently on going. Details of how these discussions have affected the preferred structural form (ST002: Single Span Integral Bridge) are discussed in Section 7 of this report.

7. LIAISON WITH KEY INTERNAL AND EXTERNAL STAKEHOLDERS

7.1 GENERAL

The proposed off-line replacement of Allerdene Bridge with single span integral bridge decks was presented to the following stakeholders for comment;

- HE Abnormal Load team (via HE PTS)
- Network Rail Third Party works
- Area 14 MAC Aone+

Implications of the above discussion are discussed below.

7.2 HE ABNORMAL LOAD TEAM

Based on initial correspondence with the HE, the new integral bridge design was developed on the understanding that abnormal loading up to 196t (SV196) would provide sufficient capacity to regulate the movement of abnormal loading along the A1.

Upon further review, the HE Abnormal Load team advised that abnormal load movements between the north and south at this location has historically meant any loads of 160t and above being routed via the A194(M) and the A184. This route is not ideal for large and or long abnormal loads, as it contains numerous roundabouts and passes through Gateshead Town Centre. The Abnormal Load team believes it would be desirable if large and heavy abnormal loads could stay on the Strategic Road Network i.e. the A1.

Based on the above, the HE Abnormal Load team requested consideration be given to ensuring all structures that carry the A1 on the proposed A1B2CH scheme, including the replacement Allerdene Bridge, have SOV 350 model load capacity (up to 350t) in their future permanent condition.

7.3 NETWORK RAIL THIRD PARTY WORKS TEAM

Refer to Appendix I for formal meeting minutes between Network Rail/Highways England and WSP|PB.

In summary, the meeting provided some clarification on the following critical assumptions made during development of the structural forms discussed in Section 6;

- Headroom: The minimum headroom between the top of rail and bridge soffit is 6.7m. This is to future proof the clearance envelope for the movement of high speed trains
- OLE: The fixing of OLE to the bridge soffit (similar to the existing situation) is prohibited. Therefore OLE will need to be supported via free standing masts. The minimum vertical clearance from the rail to the contact wire should be 4.7m. Network Rail also requested an additional 1m clearance from the top of the mast (generally 1m above the contact wire level) to the deck soffit.

- Lateral clearance: Network Rail were amenable to the proposal to position bridge supports within the Network Rail boundary, provided a minimum 4.5m clearance is maintained from the face of the supports to the nearest running rail. Network Rail also confirmed it would be the responsibility of the bridge designer/contractor to ensure no plant or equipment fall/collapse and land within 3m of any Network Rail plant or apparatus.
- Future expansion of the track: Network Rail did not have any reservations/concerns regarding the proposed cross section/clearance envelope provided by the preferred integral bridge proposal.

7.4 AREA 14 MAC – AONE+

In March 2017, Representative from Aone+ was invited to attend a progress meeting regarding the A1B2CH scheme. During the meeting Aone+ raised the following:

- Feasibility for a hybrid alignment to be developed where one of the Allerdene Bridge decks is constructed off-line whilst the other is constructed on-line.
- Feasibility of re-using the existing Allerdene Bridge substructure elements

Aone+ considered the perceived benefits from the above was a reduction in bridge construction costs and the extent of the ground stabilising works. This was based on only one deck being constructed off-line. The other deck would remain on the current A1 alignment upon which ground stabilising works are believed to have already been completed.

Upon further review, consideration to a hybrid option and re-use of existing sub structure elements was ruled out based on increased programme/construction and buildability risks. In addition the hybrid option does not align itself to providing a robust bridge design with reduced long term maintenance liabilities.

Refer to the memo that was issued to the HE, a copy of which is included within Appendix J, for full details of the issues associated with a hybrid alignment.

7.5 IMPLICATIONS OF THE STAKEHOLDER LIAISON

In light of the stakeholder liaison, the initial proposal for the off-line replacement of Allerdene Bridge was reviewed/updated to confirm that the single span integral bridge remained a feasible option for further development. The table below summarises some of the key factors considered in the additional analysis undertaken.

	INITIAL ASSUMPTION	CONFIRMED REQUIREMENT
Headroom	5.8m	6.7m
OLE	Can be fixed to the deck soffit	OLE to be supported on free standing masts. Fixing to the bridge is prohibited
Lateral clearance	Acceptable to have bridge end supports within NWR land	No objection raised by NWR, initial assumption remain valid

	INITIAL ASSUMPTION	CONFIRMED REQUIREMENT
Future proofing the structure for additional tracks	Integral bridge span proposed, limited clearance for expansion	No objection raised by NWR, initial assumption remain valid
Design Loading	Based on SV196 (equivalent to 196t loading)	Review feasibility of designing bridge to sustain SOV350 loading (>350t)

Table 7.5 Clarity on the new bridge design requirements

Section 8 provides details of the additional analysis undertaken to confirm the viability of the integral bridge proposal based on the above constraints. Details of the additional refinements to the structural form/geometry to improve buildability are also discussed.

8. REFINEMENTS TO THE PREFERRED STRUCTURAL FORM

8.1 BUILDABILITY IMPROVEMENTS

Upon review of the stakeholder requirements and further discussion with the Support Contractor (Costain) regarding buildability, the following potential risk and buildability complications were identified with the original integral bridge proposal ST002 (Refer to GA Sheet 2 of 4 in Appendix G):

- The structure footprint was embedded deep within the existing A1 embankment at the North East corner in particular. This would result in approx. 10m high retaining structures being required to construct the new bridge.
- Potential difficulties maintaining the lateral clearance to OLE equipment/masts
- Restricted access for construction of the abutment pile cap without compromising the minimum lateral clearance to Network Rail infrastructure and the track support zone.

Based on the above, the highway alignment/bridge design was reviewed and the position/geometry of the new Allerdene Bridge was adjusted so that it could be positioned further south prior to crossing of the railway whilst also maintaining the 6.7m headroom clearance. The changes to the position and geometry of Allerdene Bridge provide the following benefits;

- The lateral clearance between the existing and new bridge increases from 6m to 13m thereby providing greater confidence that the work to install the offline bridge would not disrupt traffic travelling over the existing Allerdene Bridge
- The deck at the north east corner is now located near the bottom of the A1 embankment reducing the retained height of any temporary works from 10m to approx. 2-3m, allowing for simpler cost effective solutions (e.g. sheet piles) to be considered
- The lateral clearance of the support face to the nearest running rail has increased from 4.5m to approx. 8m. This allows for the 3m clearance between the OLE to the running rail and a further 3m safety zone from the back of the OLE to the fence line to be maintained. In addition, a further 2m space is available behind the safety fence to allow construction of the bridge piles/pile cap
- The orientation/alignment of the bridge was amended to reduce the skew effects from 30 to 25 degrees. However, the improved clearance has resulted in the clear skew span increasing from 58m to 60m, the effects of which are discussed in Section 8.2

The revised position/span configuration of the integral bridge crossing has improved and de-risked the works in relation to simplified temporary works and improved access/clearance during construction.

Refer to Appendix N for updated General Arrangement drawings for the integral bridge proposal incorporating the geometric/spatial changes noted above.

Below are details of some of the other key design features considered to improve buildability and minimise risk during construction;

- Girder configuration is such that they can be lifted in pairs to improve stability during lifting and installation
- Girders shall be cut and spliced on site (points of contraflexure) to simplify transport to site
- Girders shall be lifted in pairs with permanent GRP formwork in place. This minimises Network Rail interface risks and the requirement for possession during casting of the in situ deck slab
- Cantilever parapet plinths to be avoided, simplifying design and construction of these elements. The removal of the edge cantilever results in the design for onerous accidental wheel loads being avoided, reducing cost associated with casting complex cantilever sections
- Design of the outer pair of girders to consider loads associated with fixing the temporary edge protection (Paraslim) in place prior to lifting. This will avoid additional possession works to install temporary working platforms to cast the deck edge/parapet plinth, see indicative illustration below:

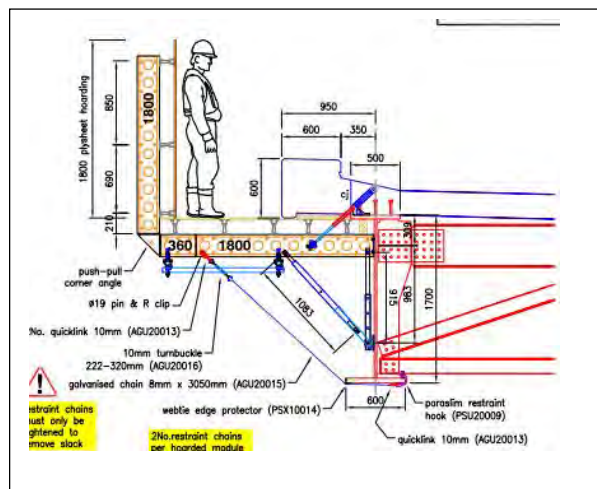

Figure 8.1 – Indicative Temporary Edge Protection

A similar sequence was successfully designed/applied on the recent Stanton Cross Bridge development scheme, a curved steel composite bridge construction. Refer to Appendix K for details.

- Abutments shall be designed to be cast in stages to minimise the height of formwork and reduce the risk of elements falling and landing within 3m of the railway infrastructure

Refer to Appendix L for the Designers Risk Assessment prepared to date for the design/construction of Allerdene Bridge.

Details of how the OLE equipment shall be accommodated during construction and in the permanent situation is recorded in a Form A document (AIP equivalent document in accordance with Network Rail procedures). This document has been prepared by WSP|PB specialist in-house OLE team and shall be submitted to Network Rail for review and approval.

Further review shall be required at detailed design to determine the extent of enabling works design to facilitate construction of the bridges. To date the key enabling works identified include:

- Embedded retaining wall structures around the perimeter of the abutment piles cap. Anticipate sheet piles will be adequate.
- Embedded retaining wall structure at the NE corner to enable construction of the bridge substructure (wingwalls) at this location. Anticipate sheet piles will be adequate.
- Foundation required to support the new OLE masts provision. Anticipate helical screw piles foundation will be sufficient

Refer to Appendix M for details of an indicative construction sequence demonstrating how the new integral bridge decks could be installed and existing Allerdene Bridge demolished. The construction sequence shall be finalised based on completion of the design and appointment of a Principal Contractor.

8.2 EFFECTS OF THE SPAN INCREASE ON THE INTEGRAL BRIDGE PROPOSAL

The design of integral bridges was previously in accordance with BA42/96 Design of Integral Bridges. However reference to IAN124/11 Annex C1 states that BA42 should no longer be referred to and alternative guidance such as PD6694-1 2011 Recommendations for the Design of Structures Subject to Traffic Loading to BS EN 1997-1:2004 should be used instead.

BA42/96 specifically stated that integral bridges are limited to spans up to 60m and a maximum skew of 30 degrees. PD6694-1 Clause 9 Integral Bridges makes reference to the skew being limited to 30 degrees (similar to BA42/96) to avoid significant plan rotation of the deck and twisting of the tops of the abutments but does not specify a limiting span requirement. Specific reference is now made to ensuring the thermal movement (function of the span) of the deck ends does not exceed 40mm.

IAN124/11 also makes reference to BD57/01 Design for Durability. Clause 2.3 of this standard state “In principle, bridges with overall lengths not exceeding 60m and skews not exceeding 30 degrees should be designed as integral bridges.” Our interpretation of this statement is that this is not a mandatory requirement and engineering judgement can be applied to determine whether a greater span length can be accommodated within acceptable limits of thermal movement.

For the proposed new integral bridge design for Allerdene Bridge, the effective span is now 62.6m with a max skew of 25 degrees. Based on the above, we considered that a departure from standard would not be required. Initial correspondence with the HE PTS during the study indicated they were in agreement with the above principles, subject to sufficient analysis being undertaken to demonstrate that a single span integral bridge in excess of 60m would provide a feasible solution.

Details of the initial preliminary analysis undertaken to confirm the viability of a 62m integral bridge proposal for the offline replacement of Allerdene Bridge is provided in Section 8.3.

8.3 DETAILS OF PRELIMINARY ANALYSIS

The preliminary analysis was based on the details of the integral bridge decks (Option A) provided in the general arrangement drawings within Appendix N. Key geometric information includes:

- Effective Skew Span: 62.6m (clear span between abutments 60.6m)
- Deck Width: 21.05m
- Carriageway width (between kerb lines): 16.75m
- Skew: 25 degrees
- Girder spacing: 2.75m
- No. of beams: 8

The wider of the two independent structures (southbound bridge) was considered for the preliminary analysis. This yielded conservative results that allowed for engineering judgement to be applied confirming the adequacy of the smaller northbound bridge deck.

During the preliminary analysis, the critical deck elements were checked in detail. This was important to demonstrate that the deck could work structurally for the applied loading without compromising the 6.7m clearance which had to be maintained. The abutment walls are not as constrained and therefore these elements can be more readily modified to sustain the applied load effects due to earth pressures and surcharge.

Initial high level checks showed the proposed 2.5m thickness for the abutment walls would be adequate for applied load effects without reinforcement congestion issues. It is expected that the abutment design will be refined at detailed design to ensure the substructure is strong enough to resist lateral pressures yet flexible enough to accommodate movement.

The deck was initially analysed taking into account all construction stages. Initial stresses in the simply supported beams were calculated using elastic theory taking into account the following steps:

- Stresses in beams under self-weight
- Stress in beams under self-weight + wet concrete deck slab

On the assumption that the beams are then installed and connections between the beams and the abutments have achieved full strength, the bridge was analysed as a portal frame structure. The portal frame was analysed using a space frame created in MIDAS. In the absence of detailed pile analysis the abutment were assumed to be founded on rock.

The soil loading behind the abutment wall was derived in accordance with the earth pressure distribution for frame abutments given in document PD 6694-1 : 2011 – Recommendations for the design of structures subject to traffic loading to BS EN 1997-1 : 2004.

Within the design of the composite section, the following stresses were considered:

- Stresses in beams with fixture and fittings (e.g. waterproofing, steel parapet)
- Stresses in beam with super imposed dead load
- Live loading
- Differential settlements
- Stresses due to temperature expansion and contraction with k^* pressure
- Stresses due to temperature gradient
- Creep and shrinkage (short / long term)

Loading was applied on the deck in accordance with the Eurocodes. The live loading application was based on a number of notional lanes appropriate to the available width from kerb to kerb.

Some of the key structural checks to confirm the feasibility of the integral deck design included:

- Internal stability checks during construction
- Bending (sagging) at midspan
- Bending (hogging) at support
- Deck slab transverse bending effects – Local effects
- Deck slab punching shear – Local effects
- Thermal Movement
- Deflection limits

8.4 RESULTS OF PRELIMINARY ANALYSIS

In accordance with GA sheet 1 of 2 in Appendix N, the preliminary analysis was based on a typical girder with the following dimensions.

	WIDTH (DEPTH IN RELATION TO WEB)	THICKNESS
Top Flange(mm)	650	50
Bottom Flange(mm)	750	60
Web(mm)	1890	25
Area (mm ²)		124750

The results of the preliminary deck analysis were as follows:

- Able to sustain SV196 with associated LM1 loading in adjacent lanes

- Fails to sustain SOV350 with associated LM1 loading in adjacent lanes
- Able to sustain SOV350 alone when passing over lanes 1, 2 or 3 (located centrally). Considering abnormal loads tend to travel in the slower lanes (lane 1) this is not envisaged to be a significant constraint.

The governing criteria limiting the capacity of the deck were the applied bending effects to the inner edge beam at the central reserve location. This was due to the limited distribution of loading due to the higher stiffness of the edge beam attracting more load and also the close proximity of the applied loading within lane 4.

In comparison, the applied load effect on the outer edge beam (verge side) was less due to the increased verge width resulting in the loading in lane 1 being further away from the edge beam. This promotes greater distribution of loading to the adjacent intermediate beams.

The anticipated bridge beam deflections were;

- 210mm under permanent load
- 40mm under live load

The deck would be precambered such that the required 6.7m headroom is maintained taking into account the deflections noted above.

Thermal expansion/contraction of the deck was determined in accordance with BS EN 1991-1-5:2003 General Actions – Thermal Actions by simple hand calculation based on a 62m span length (L), Consideration of a temperature differential of 40 degrees Celsius and a coefficient of linear thermal expansion of 12×10^{-6} per degree Celsius showed the total expected movement to be 30mm. This correlated well with the movement calculated via the analysis model of +/-15mm (total 30mm).

Integral bridges in the UK generally have simple asphaltic plug joints at the transition between the bridge deck and the pavement beyond the bridge. The total movement range for such joints as stated in BD33/94 is 40mm. Therefore the anticipated thermal movement of the proposed 62m integral bridge is within the limits of an asphaltic joint provision.

The analysis has shown that a 62m integral bridge with 2m deep girders at 2.75m spacing would be able to accommodate the SOV350 loading if regulated to travel alone over the bridge in lanes 1-3 (away from lane 4). This restriction would need to be discussed and confirmed with the HE abnormal load team. Taking into account the assumed limited frequency of this abnormal load movement and the reduced probability of this load travelling in lane 4 (fast lane). It is reasonable for a proposed restriction for SOV350 to travel alone to be considered.

The alternative to abnormal load restrictions would be modifications to the girder configuration to improve the resistance to the critical bending effects.

The mode of failure/limiting capacity is governed by the inner edge beam (central reserve) bending capacity directly adjacent to lane 4. The provision of a greater number of beams at closer beam centres to increase load distribution is not considered to provide a cost effective solution. This is due to the loading currently being positioned almost directly over the edge beam such that distribution to adjacent beams would be limited, unless the beams are so closely spaced it becomes both impractical and uneconomical.

The most cost effective solution would be the increase in girder depth by approx. 100mm and also increasing the thickness of flange and webs as per the table below. Refer to GA Option B in Appendix N.

	WIDTH (DEPTH IN RELATION TO WEB)	THICKNESS
Top Flange(mm)	650	50
Bottom Flange(mm)	900	80
Web(mm)	1970	25
Area (mm ²)		151250

The result of the preliminary deck analysis based on the revised girder configuration was as follows.

- Able to sustain SV196 with associated LM1 loading in adjacent lanes
- Able to sustain SOV350 (any lane) with associated LM1 loading in adjacent lanes

Further assessment of the alignment would need to be undertaken by the Highways discipline to confirm that the bridge can sustain the required 6.7m clearance and vertical alignment over the bridge for the increased construction depth.

The preliminary analysis based on the information to date has demonstrated that the replacement of Allerdene Bridge with a 62m integral bridge form is a viable option for the off-line replacement of Allerdene Bridge. An integral bridge would provide a robust cost effective solution with significant long-term maintenance benefits.

The estimated construction cost of a 62m integral bridge option would be £12-13 million. (Note the HE Cost Estimating Team has not been consulted for any costing information for this study).

9. CONCLUSION & RECOMMENDATION

9.1 CONCLUSION

The existing Allerdene Railway Bridge has a number of inherent design/construction deficiencies which cannot be easily resolved due to the complex structural form (half joints) and site constraints. Therefore it shall be replaced as part of the A1 Birtley to Coalhouse Improvement scheme.

Two alignment options are currently being assessed for the replacement of Allerdene Bridge. These are;

- Option 1: Promotes the online replacement of the A1 and existing Allerdene Bridge, between Junction 67 (Coal House) and Smithy Lane Overbridge. This alignment would require temporary off-line bridges.
- Option 2: Promotes the realignment of the A1 to the south of the existing Allerdene Bridge, between Junction 67 (Coal House) and Smithy Lane Overbridge. This alignment allows for a fully off-line Allerdene Bridge replacement.

The assessment to date inclines towards Option 2 (also referred to as Option 1a) being the preferred route based on programme and cost benefits in addition to improved buildability.

Various structural forms and span configurations were assessed for the off-line replacement of Allerdene Bridge. The preliminary analysis has demonstrated that a 62m integral bridge form is a viable option for the off-line replacement of Allerdene Bridge. An integral bridge would provide a robust cost effective solution with significant long-term maintenance benefits.

The estimated construction cost of a 62m integral bridge option would be £12-13 million.

Further liaison with key stakeholders such as Statutory Undertakers/Network Rail/ HE Abnormal Load team is required to formally approve and sign off the integral bridge proposal for further development at detailed design.

9.2 RECOMMENDATION

Based on the studies to date, it is recommended that the off-line replacement of Allerdene Bridge be further developed.

The following should be undertaken to further validate the integral bridge recommendation made in this report.

- Liaison with Statutory Undertakers – confirm diversion to undertake the works
- Liaison with Network Rail including submission of draft technical approval documents (AIP/Form A for the integral bridge design and OLE works) for formal approval.
- Liaison with the HE abnormal load team to confirm abnormal loading requirements prior to detailed design

The above would provide clarity on the constraints to be considered for the offline bridge design and ensure abortive works are negated at detailed design stage.

Appendix A

INDICATIVE SCHEMATIC PLANS

Appendix A-1

HIGHWAY ALIGNMENT OPTION 1

DO NOT SCALE

Millimetres
0 10 100

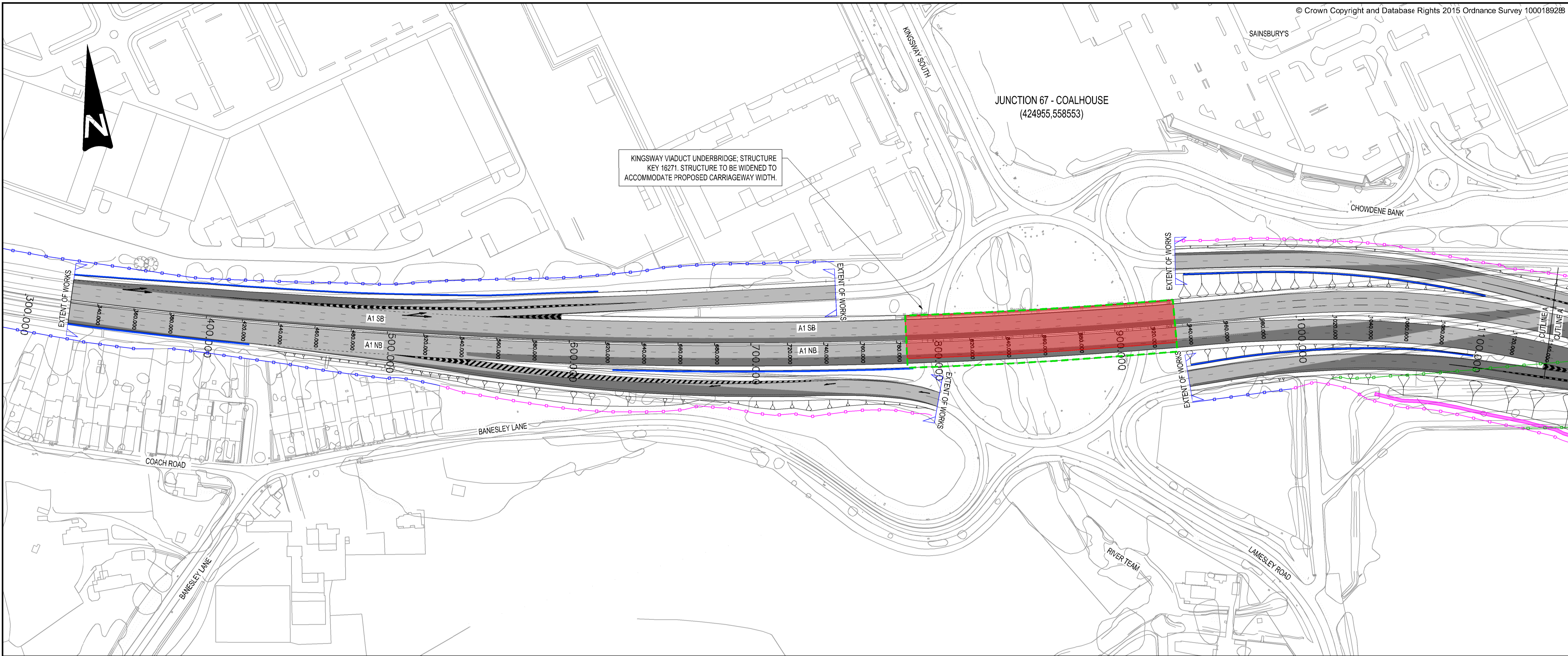

KEY

- EXISTING STRUCTURE
- PROPOSED STRUCTURE
- PROPOSED RETAINING WALL
- PROPOSED HIGHWAYS FENCE LINE
- RETAINED EXISTING HIGHWAYS FENCE LINE
- REMOVED EXISTING HIGHWAYS FENCE LINE
- NEW CARRIAGEWAY CONSTRUCTION
- EXISTING CARRIAGEWAY TO BE RETAINED
- PROPOSED DRAINAGE DITCH
- NETWORK RAIL LAND BOUNDARY

A1

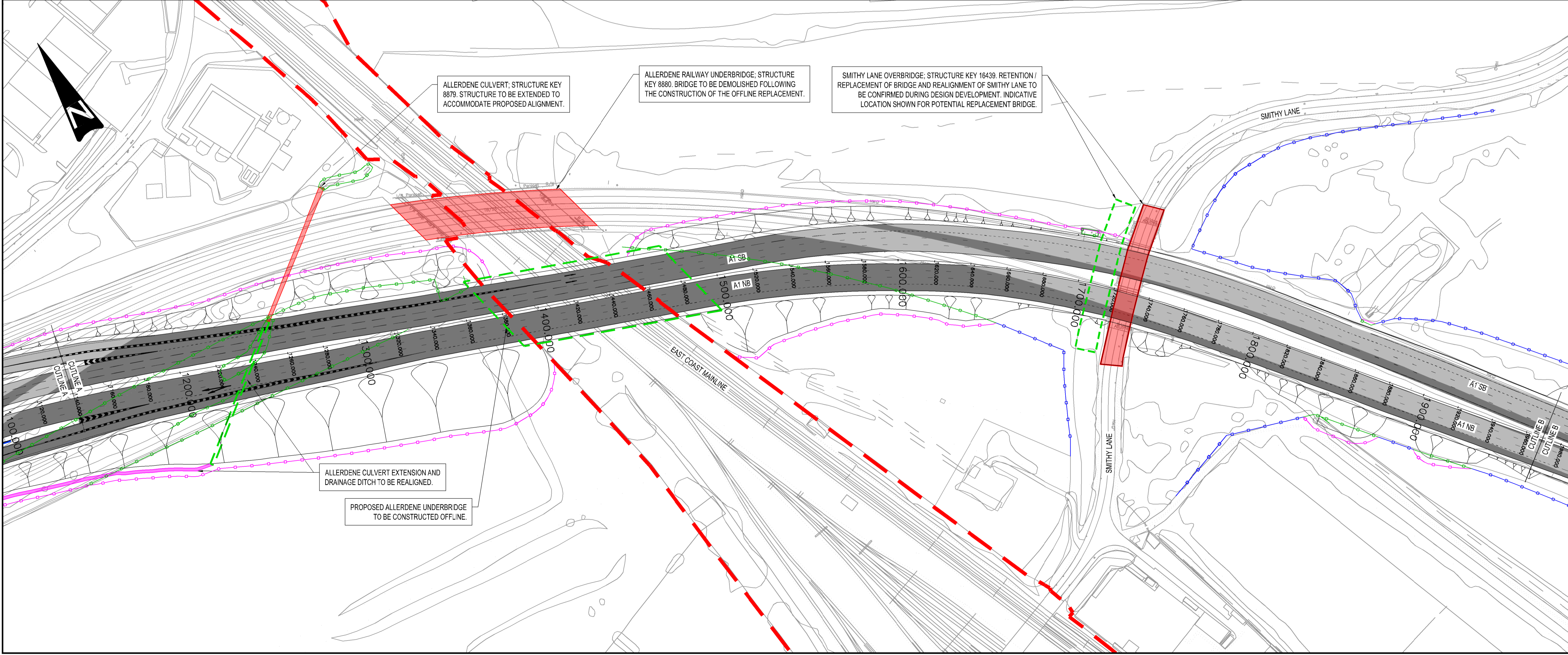

P01	05/09/16	FOR INFORMATION	JAC		
P02	07/09/16	MINOR AMENDMENTS TO BMS & STRUCTURES CHANGE ADDD	JWL	CP	NGR
P03	07/09/16	ISSUED FOR PUBLIC CONSULTATION	JWL	SG	NGR
P04	10/02/17	DESIGN DEVELOPMENT POST PUBLIC CONSULTATION	JWL	SG	NGR
Rev.	Date	Description	By	Chkd	Appd

WSP Three White Rose Office Park,
Millshaw Park Lane,
Leeds, LS11 0DL
Tel: +44 (0)113 395 6200

PARSONS BRINCKERHOFF

© WSP UK Ltd www.wsp-pb.com

Client **Working on behalf of**

highways england

Project Title **A1 BIRTLEY TO COALHOUSE**

Drawing Title **OPTION 1A - OFFLINE REPLACEMENT OF ALLERDENE RAILWAY BRIDGE WITH RETENTION OF COAL HOUSE JCT GENERAL ARRANGEMENT SHEET 1 OF 3**

Scale	1:1250	Drawn	J.Longmore	Checked	S.Ghosh	Approved	N.Rawcliffe	Authorised	---
Original Size	A1	Date	10/02/17	Date	10/02/17	Date	10/02/17	Date	---

Drawing Status **INITIAL STATUS OR WIP** S0

Drawing Number	HE551462	Project	BCH	Originator	WSP	Volume	HGN	Project Ref. No.	
Location	DR	Type	D	Role	10004	Number		Revision	P04

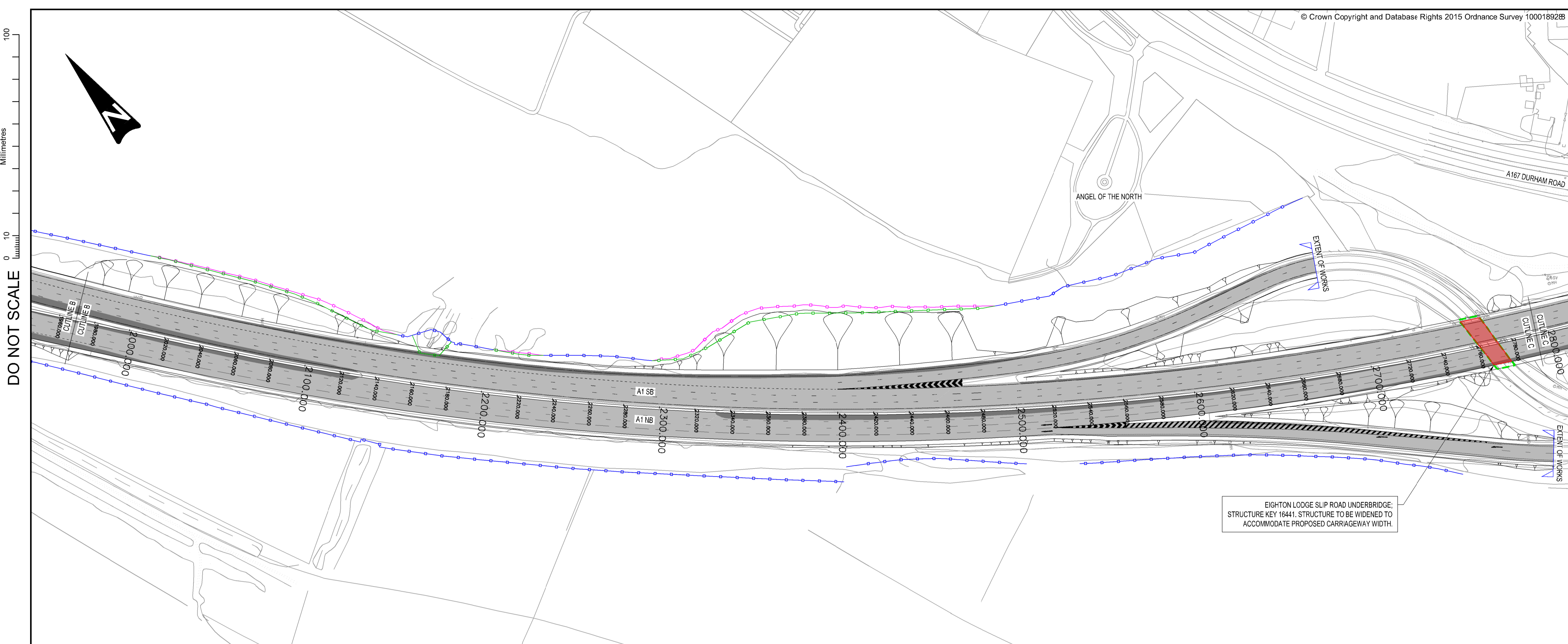

KEY

- EXISTING STRUCTURE
- PROPOSED STRUCTURE
- PROPOSED HIGHWAYS FENCE LINE
- EXISTING HIGHWAYS FENCE LINE
- REMOVED EXISTING HIGHWAYS FENCE LINE
- NEW CARRIAGEWAY CONSTRUCTION
- EXISTING CARRIAGEWAY TO BE RETAINED
- PROPOSED FOOTPATH DIVERSION
- EXISTING FOOTPATH
- PROPOSED SIGNAL
- EXISTING SIGNAL

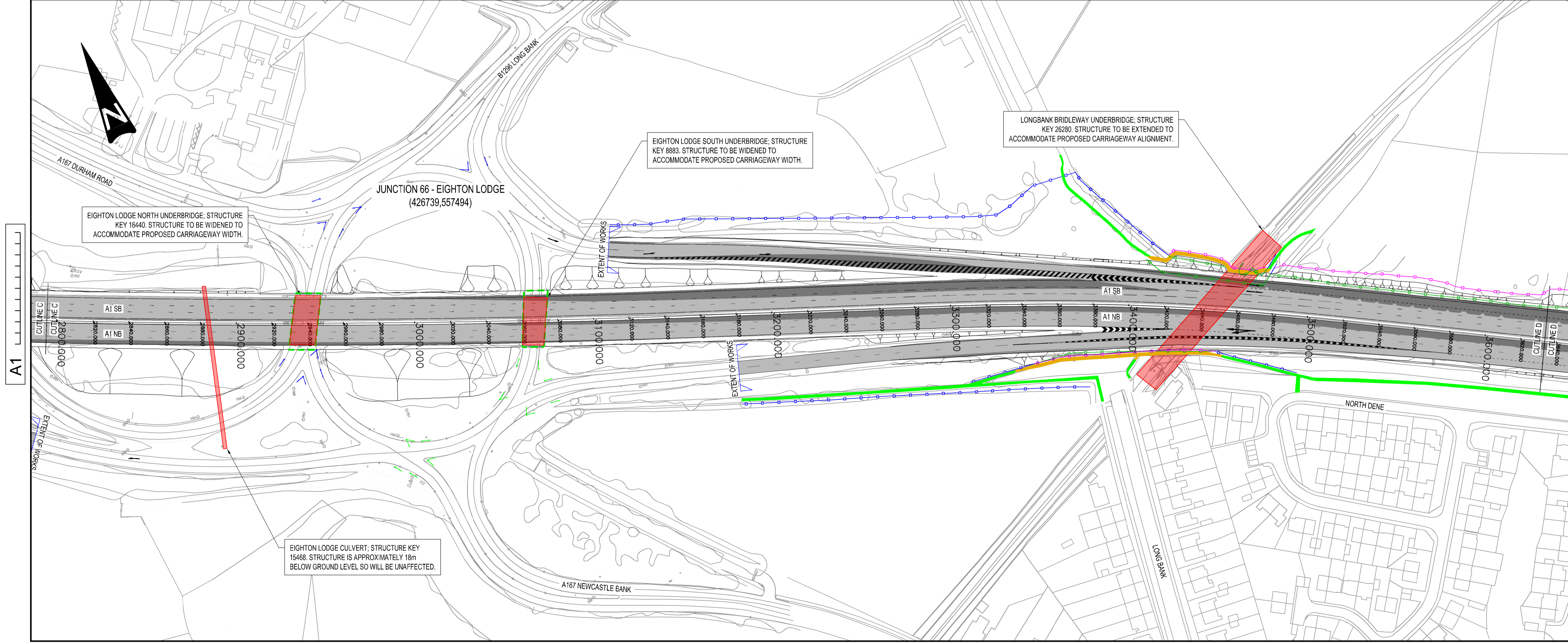

PO1	05/09/16	FOR INFORMATION	JAC		
PO2	07/09/16	MINOR AMENDMENTS TO DWGS & STRUCTURES. CHANGE ADDED	JWL	CP	NGR
PO3	07/09/16	ISSUED FOR PUBLIC CONSULTATION	JWL	SG	NGR
PO4	10/02/17	DESIGN DEVELOPMENT POST PUBLIC CONSULTATION	JWL	SG	NGR
Rev.	Date	Description	By	Chkd	Appd

WSP Three White Rose Office Park, Millshaw Park Lane, Leeds, LS11 0DL. Tel: +44 (0)113 395 6200

PARSONS BRINCKERHOFF

© WSP UK Ltd www.wsp-pb.com

Client **Working on behalf of**

highways england

Project Title **A1 BIRTLEY TO COALHOUSE**

Drawing Title **OPTION 1A - OFFLINE REPLACEMENT OF ALLERDENE RAILWAY BRIDGE WITH RETENTION OF COAL HOUSE JCT GENERAL ARRANGEMENT SHEET 2 OF 3**

Scale	1:1250	Drawn	J.Longmore	Checked	S.Ghosh	Approved	N.Rawcliffe	Authorised	---
Original Size	A1	Date	10/02/17	Date	10/02/17	Date	10/02/17	Date	---
Drawing Status	INITIAL STATUS OR WIP								S0

Drawing Number	HE551462	Originator	WSP	Volume	HGN	Project Ref. No.	
BCH	DR	D	10005			Revision	P04
Location		Type		Role			

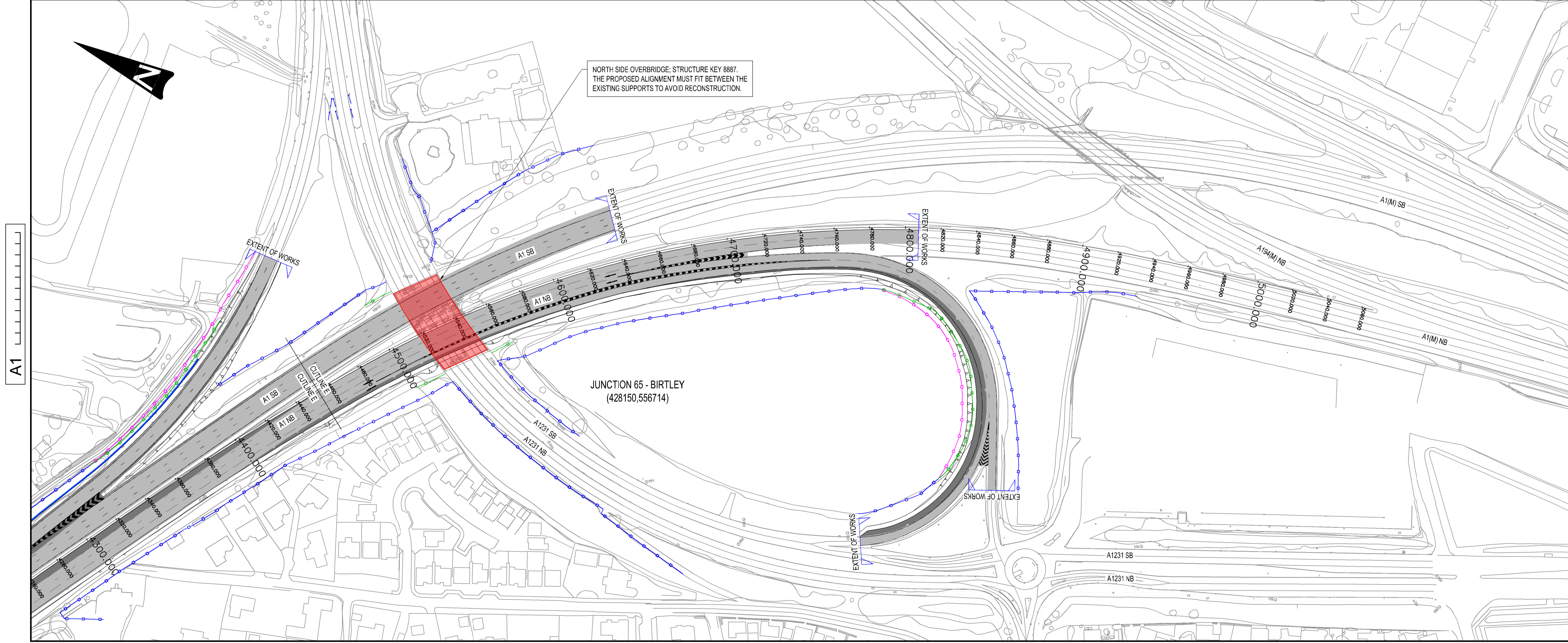
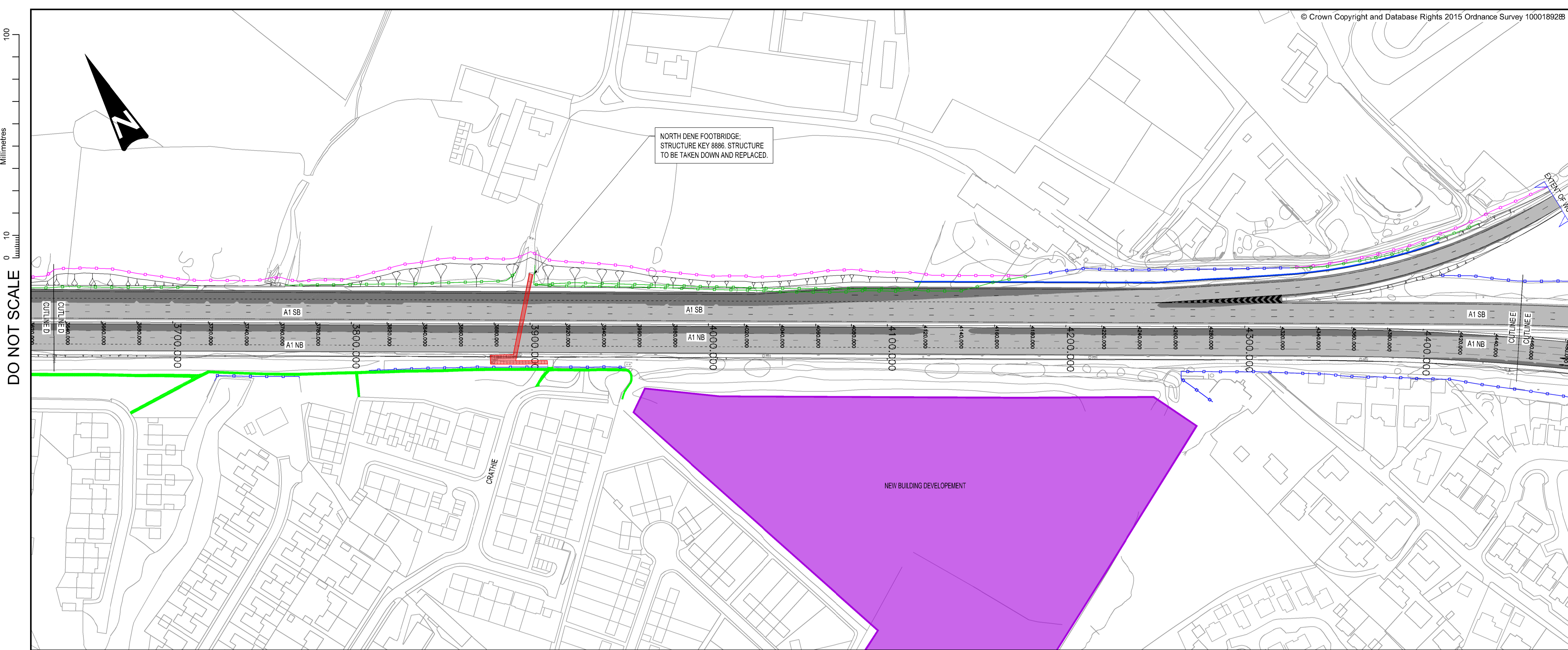

KEY

- EXISTING STRUCTURE
- PROPOSED RETAINING WALL
- PROPOSED HIGHWAYS FENCE LINE
- EXISTING HIGHWAYS FENCE LINE
- REMOVED EXISTING HIGHWAYS FENCE LINE
- NEW CARRIAGEWAY CONSTRUCTION
- EXISTING CARRIAGEWAY TO BE RETAINED
- PROPOSED FOOTPATH DIVERSION
- EXISTING FOOTPATH
- PROPOSED SIGNAL
- EXISTING SIGNAL

DO NOT SCALE

A1

Rev.	Date	Description	By	Chkd	Appd
P01	05/09/16	FOR INFORMATION	JAC		
P02	07/09/16	MINOR AMENDMENTS TO DWGS & STRUCTURES CHANGE ADDED	JWL	CP	NGR
P03	07/09/16	ISSUED FOR PUBLIC CONSULTATION	JWL	SG	NGR
P04	10/02/17	DESIGN DEVELOPMENT POST PUBLIC CONSULTATION	JWL	SG	NGR

WSP Three White Rose Office Park,
Millshaw Park Lane,
Leeds,
LS11 0DL
Tel: +44 (0)113 395 6200

PARSONS BRINCKERHOFF

© WSP UK Ltd www.wsp-pb.com

Client **Working on behalf of**
highways england

Project Title **A1 BIRTLEY TO COALHOUSE**

Drawing Title **OPTION 1A - OFFLINE REPLACEMENT OF ALLERDENE RAILWAY BRIDGE WITH RETENTION OF COAL HOUSE JCT GENERAL ARRANGEMENT SHEET 3 OF 3**

Scale	1:1250	Drawn	J.Longmore	Checked	S.Ghosh	Approved	N.Rawcliffe	Authorised	---
Original Size	A1	Date	10/02/17	Date	10/02/17	Date	10/02/17	Date	---

Drawing Status **INITIAL STATUS OR WIP** Suitability **S0**

Drawing Number	HE551462	Originator	WSP	Volume	HGN	Project Ref. No.	
Location	BCH	Type	DR	Role	D 10006	Revision	P04

Appendix A-2

HIGHWAY ALIGNMENT OPTION 2

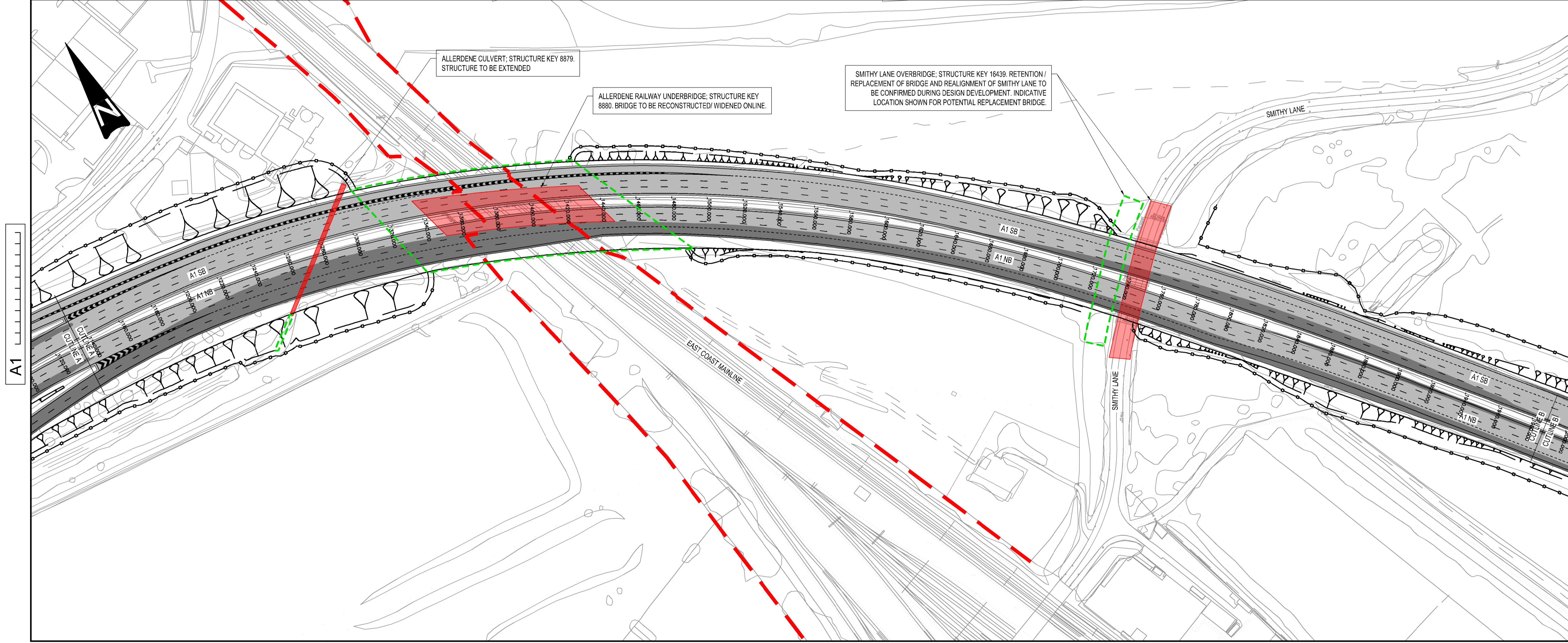
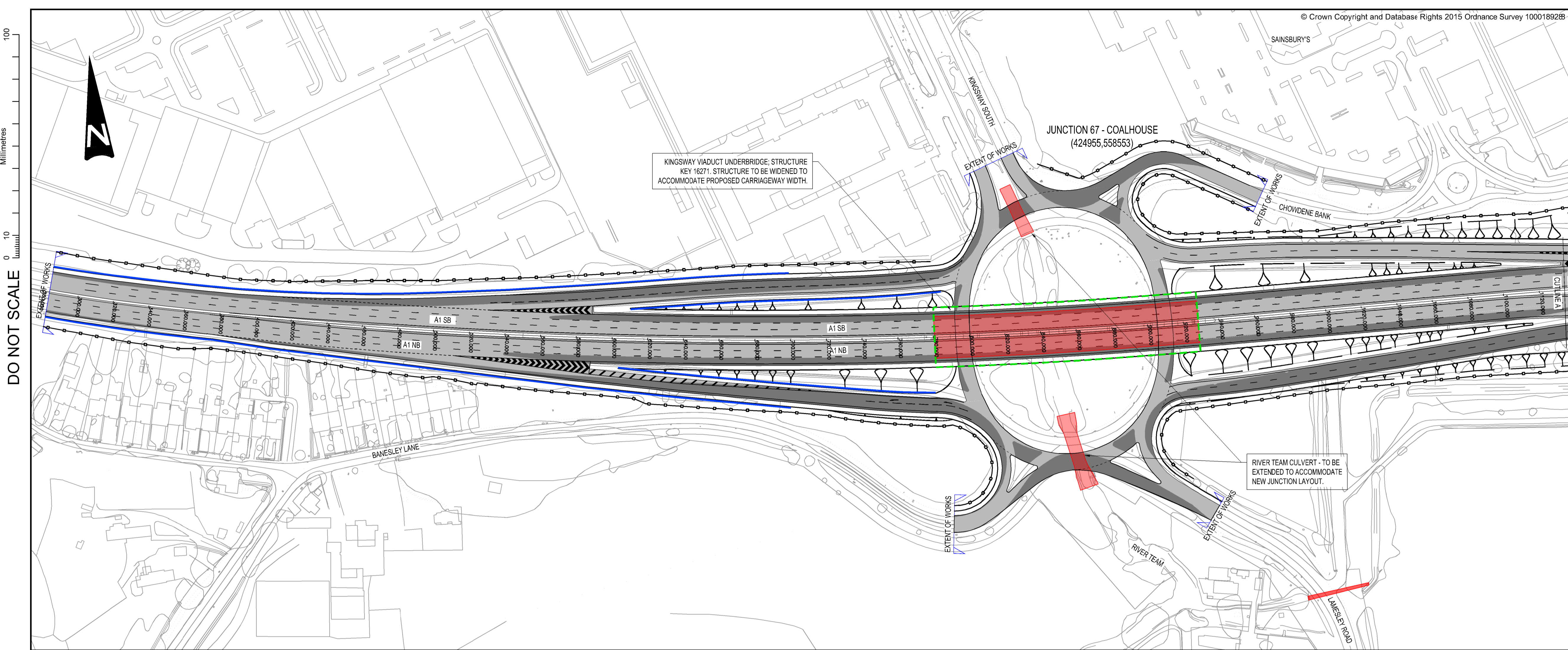

KEY

- EXISTING STRUCTURE
- PROPOSED STRUCTURE
- PROPOSED RETAINING WALL
- PROPOSED HIGHWAYS FENCE LINE
- NEW CARRIAGEWAY CONSTRUCTION
- EXISTING CARRIAGEWAY TO BE RETAINED
- PROPOSED DRAINAGE DITCH
- PROPOSED FOOTPATH DIVERSION
- NETWORK RAIL LAND BOUNDARY
- PROPOSED SIGNAL
- EXISTING SIGNAL

DO NOT SCALE

A1

P01.2	14/06/16				
Rev.	Date	Description	By	Chkd	Appd

WSP Three White Rose Office Park, Millshaw Park Lane, Leeds, LS11 0DL. Tel: +44 (0)113 395 6200

PARSONS BRINCKERHOFF

© WSP UK Ltd www.wsp-pb.com

Client **Working on behalf of**

highways england

Project Title **A1 BIRTLEY TO COALHOUSE**

Drawing Title **OPTION 1B - ONLINE REPLACEMENT OF ALLERDENE RAILWAY BRIDGE GENERAL ARRANGEMENT SHEET 1 OF 3**

Scale	1:1250	Drawn	---	Checked	---	Approved	---	Authorised	---
Original Size	A1	Date	---	Date	---	Date	---	Date	---
Drawing Status	Initial Status or WIP								S0
Drawing Number	HE551462	Project	BCH	Originator	WSP	Volume	HGN	Project Ref. No.	
Location	DR	Type	D	Role	10001	Number		Revision	P01.2

DO NOT SCALE

Millimetres
0 10 100

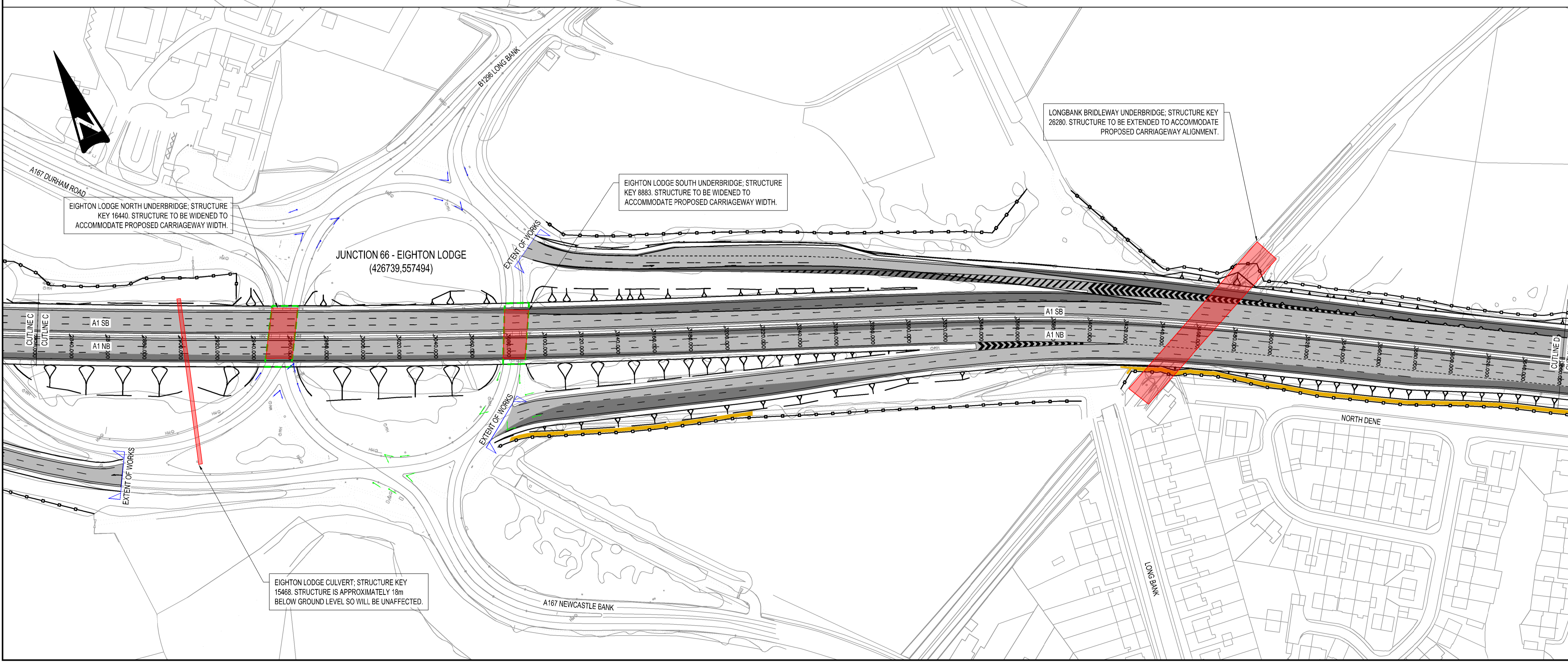
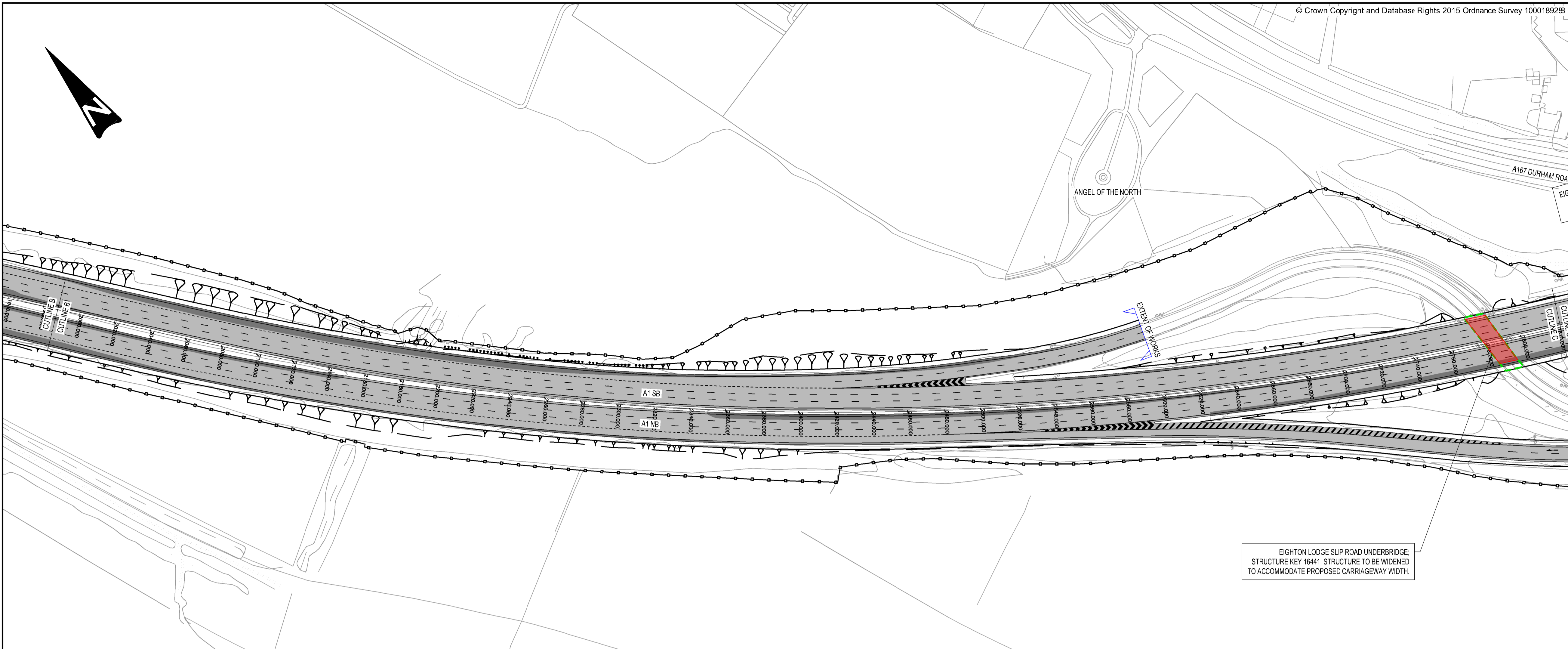

KEY

	EXISTING STRUCTURE
	PROPOSED STRUCTURE
	PROPOSED RETAINING WALL
	PROPOSED HIGHWAYS FENCE LINE
	NEW CARRIAGEWAY CONSTRUCTION
	EXISTING CARRIAGEWAY TO BE RETAINED
	PROPOSED DRAINAGE DITCH
	PROPOSED FOOTPATH DIVERSION
	NETWORK RAIL LAND BOUNDARY
	PROPOSED SIGNAL
	EXISTING SIGNAL

P01.2	14/06/16				
Rev.	Date	Description	By	Chkd	Appd

WSP Three White Rose Office Park, Millshaw Park Lane, Leeds, LS11 0DL. Tel: +44 (0)113 395 6200

PARSONS BRINCKERHOFF

© WSP UK Ltd www.wsp-pb.com

Client **Working on behalf of**

highways england

Project Title **A1 BIRTLEY TO COALHOUSE**

Drawing Title **OPTION 1B - ONLINE REPLACEMENT OF ALLERDENE RAILWAY BRIDGE GENERAL ARRANGEMENT SHEET 2 OF 3**

Scale	1:1250	Drawn	---	Checked	---	Approved	---	Authorised	---
Original Size	A1	Date	---	Date	---	Date	---	Date	---

Drawing Status **Initial Status or WIP** Suitability **S0**

Drawing Number	HE551462	Project	BCH	Originator	WSP	Volume	HGN	Project Ref. No.	
Location		Type	DR	Role	D	Number	10002	Revision	P01.2

DO NOT SCALE
0 10 100
Millimetres

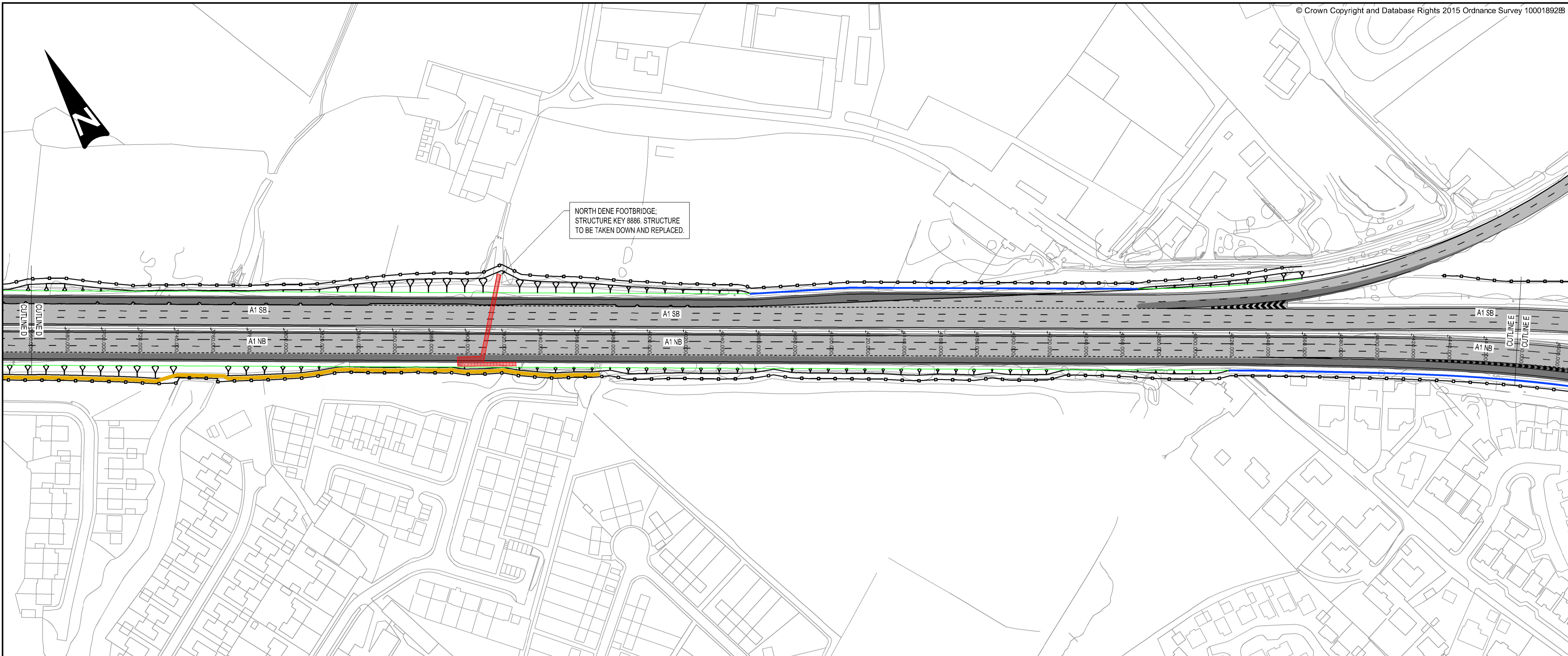

NORTH DENE FOOTBRIDGE:
STRUCTURE KEY 8886. STRUCTURE
TO BE TAKEN DOWN AND REPLACED.

A1

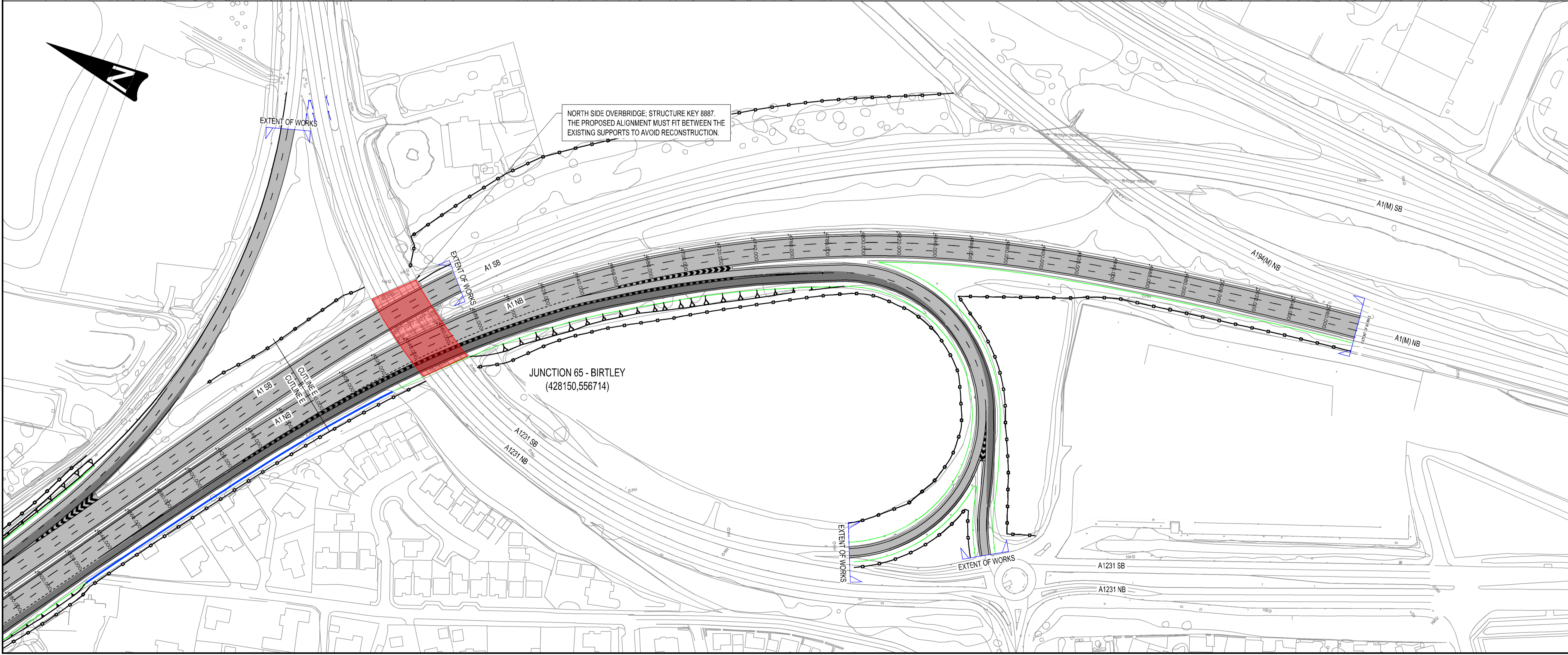

NORTH SIDE OVERBRIDGE: STRUCTURE KEY 8887.
THE PROPOSED ALIGNMENT MUST FIT BETWEEN THE
EXISTING SUPPORTS TO AVOID RECONSTRUCTION.

- KEY**
- EXISTING STRUCTURE
 - PROPOSED STRUCTURE
 - PROPOSED RETAINING WALL
 - PROPOSED HIGHWAYS FENCE LINE
 - NEW CARRIAGEWAY CONSTRUCTION
 - EXISTING CARRIAGEWAY TO BE RETAINED
 - PROPOSED DRAINAGE DITCH
 - PROPOSED FOOTPATH DIVERSION
 - NETWORK RAIL LAND BOUNDARY
 - PROPOSED SIGNAL
 - EXISTING SIGNAL

P01.2	14/06/16				
Rev.	Date	Description	By	Chk'd	App'd

Three White Rose Office Park,
Millshaw Park Lane,
Leeds,
LS11 0DL
Tel: +44 (0)113 395 6200

© WSP UK Ltd www.wsp-pb.com

Client
Working on behalf of

Project Title **A1 BIRTLEY TO COALHOUSE**

Drawing Title
**OPTION 1B - ONLINE REPLACEMENT OF
ALLERDENE RAILWAY BRIDGE
GENERAL ARRANGEMENT
SHEET 3 OF 3**

Scale: 1:1250	Drawn: ---	Checked: ---	Approved: ---	Authorised: ---
Original Size: A1	Date: ---	Date: ---	Date: ---	Date: ---
Drawing Status: Initial Status or WIP				Suitability: S0
Drawing Number: HE551462	Project: BCH	Originator: WSP	Volume: HGN	Project Ref. No.: P01.2
Location: DR	Type: D	Role: 10003	Number: 10003	Revision: ---

Appendix B

LOCATION PLAN

Appendix B-1

ALLERDENE BRIDGE LOCATION PLAN



Gateshead Metro Centre

Team Valley Trading Estate

Team Valley Retail Park

8880 Allerdene Bridge

16271 Kingsway Viaduct



TITLE:
Plan View of Allerdene Bridge and the Surrounding Area
Sheet 1 of 2

FIGURE No:
HA 551462-WSP-SBR-BCH-SK-S-1700-001



Key

- 66kV Overhead Lines
- Network Rail Boundary

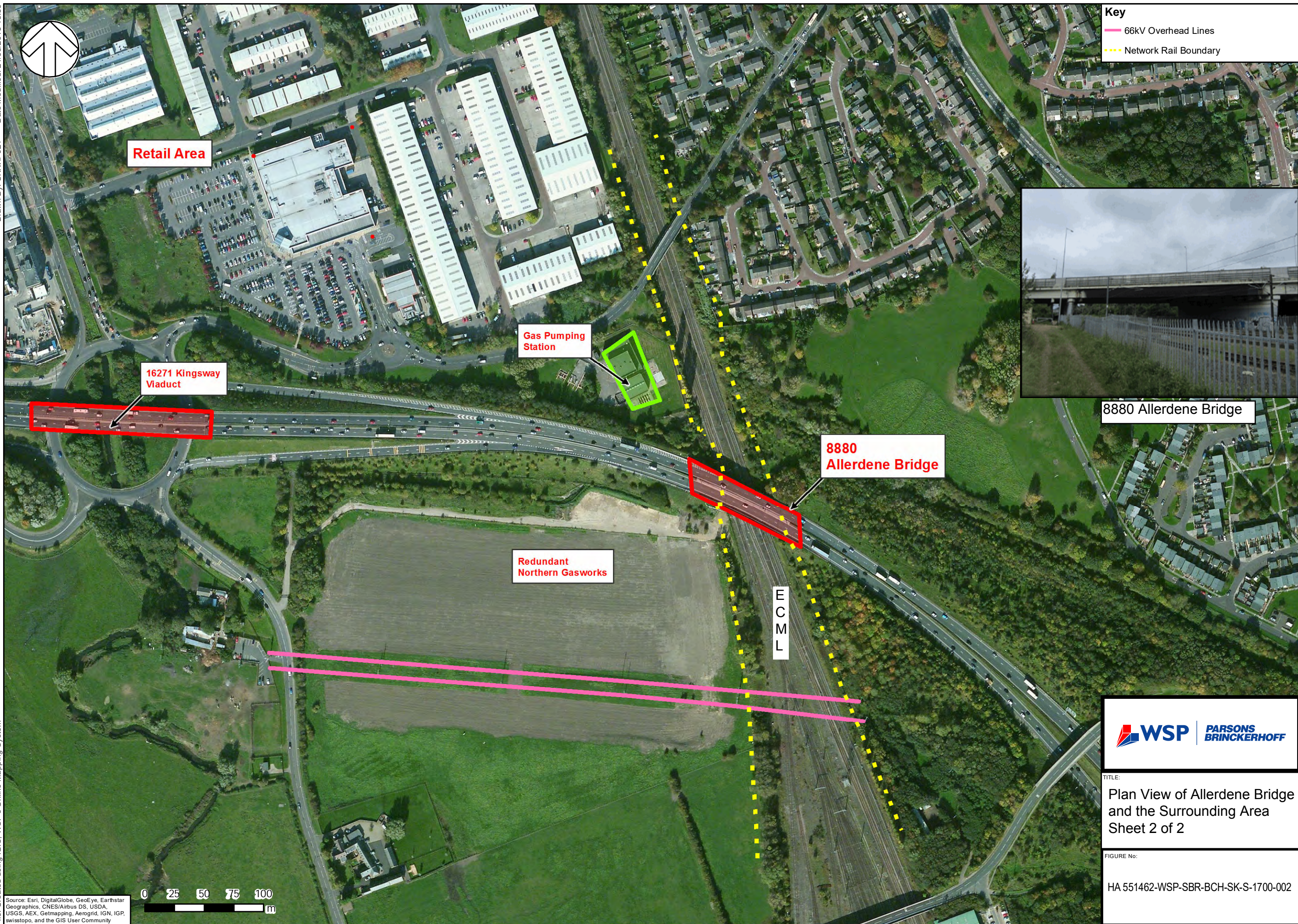

8880 Allerdene Bridge

8880 Allerdene Bridge

Retail Area

16271 Kingsway Viaduct

Gas Pumping Station

Redundant Northern Gasworks

E
C
M
L



TITLE:
Plan View of Allerdene Bridge
and the Surrounding Area
Sheet 2 of 2

FIGURE No:
HA 551462-WSP-SBR-BCH-SK-S-1700-002

Appendix C

ALLERDENE BRIDGE EXISTING AS BUILT RECORDS

Appendix C-1

EXISTING GA & STRENGTHENING DETAILS

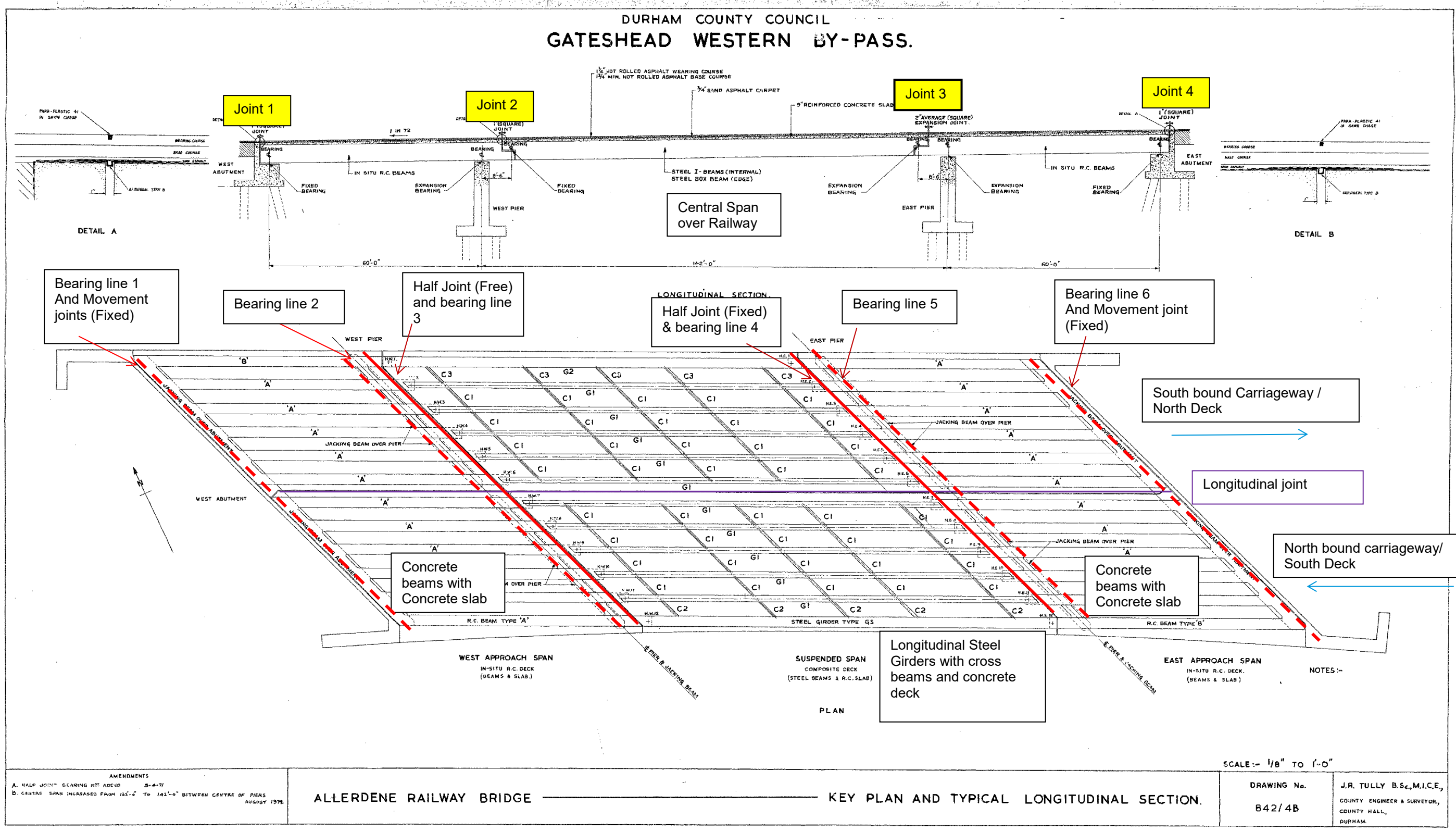
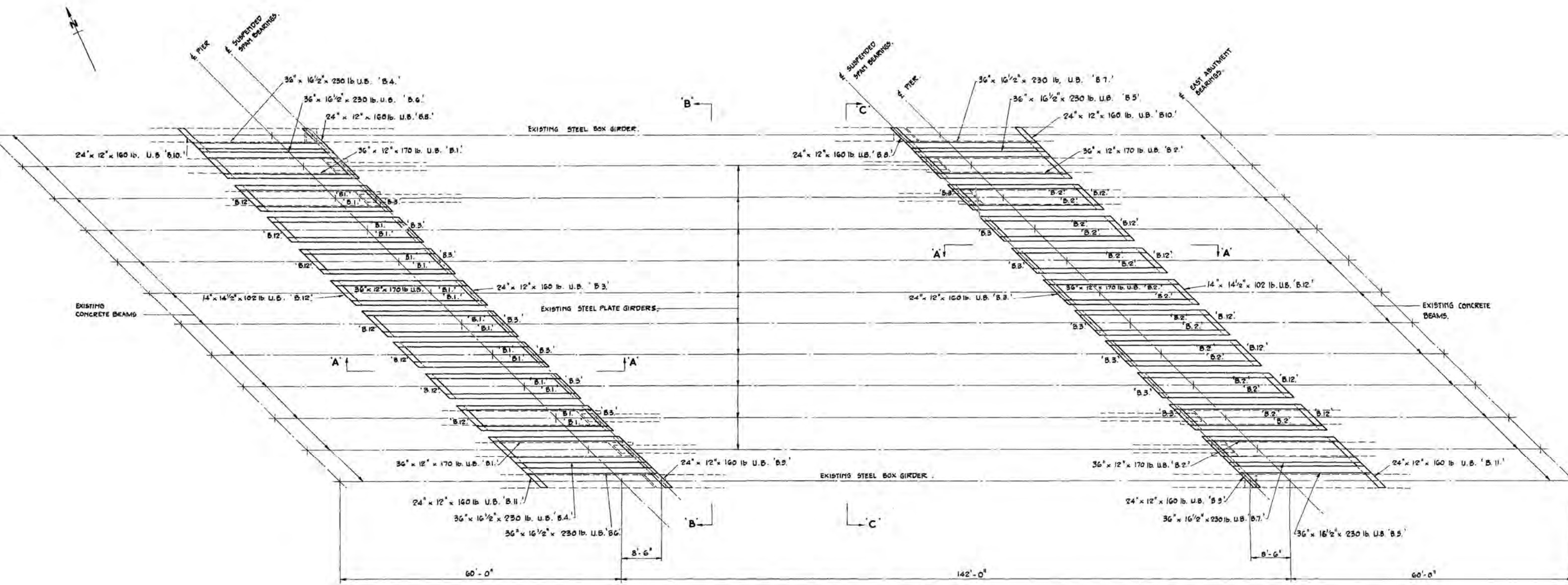
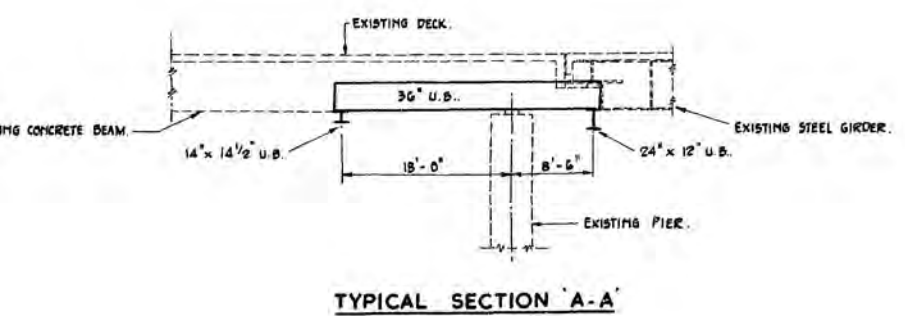

Figure 1: Drawing showing the General Arrangement of the Bridge.

DURHAM COUNTY COUNCIL GATESHEAD WESTERN BY-PASS



MARKING PLAN OF ADDITIONAL SUPPORT STEELWORK.



TYPICAL SECTION A-A

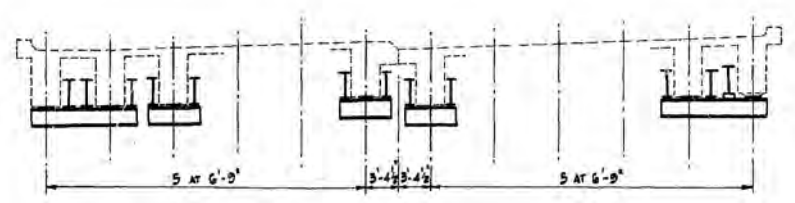

**SECTION B-B
('C-C' OPPOSITE HAND)**

NOTES:-
1. ADDITIONAL SUPPORT STEELWORK TO BE CASED IN CONCRETE WITH 2" MINIMUM COVER.

SCALE:- 1/8" = 1'-0"

AMENDMENTS
FROM 24" x 12" TO 14" x 14 1/2" (17-1-75)

ALLERDENE RAILWAY BRIDGE.

**ADDITIONAL SUPPORT STEELWORK
GENERAL ARRANGEMENT**

J. R. TULLY, B.Sc., M.I.C.E., F.I. Mun. E.,
COUNTY ENGINEER,
COUNTY HALL,
DURHAM.

DRAWING
842 /

Appendix D

**A1BSCH GENERAL SERVICES PLANS (SHEET 1 OF 3 CONTAINS
ALLERDENE BRIDGE)**

Appendix D-1

A1B2CH SERVICES PLANS

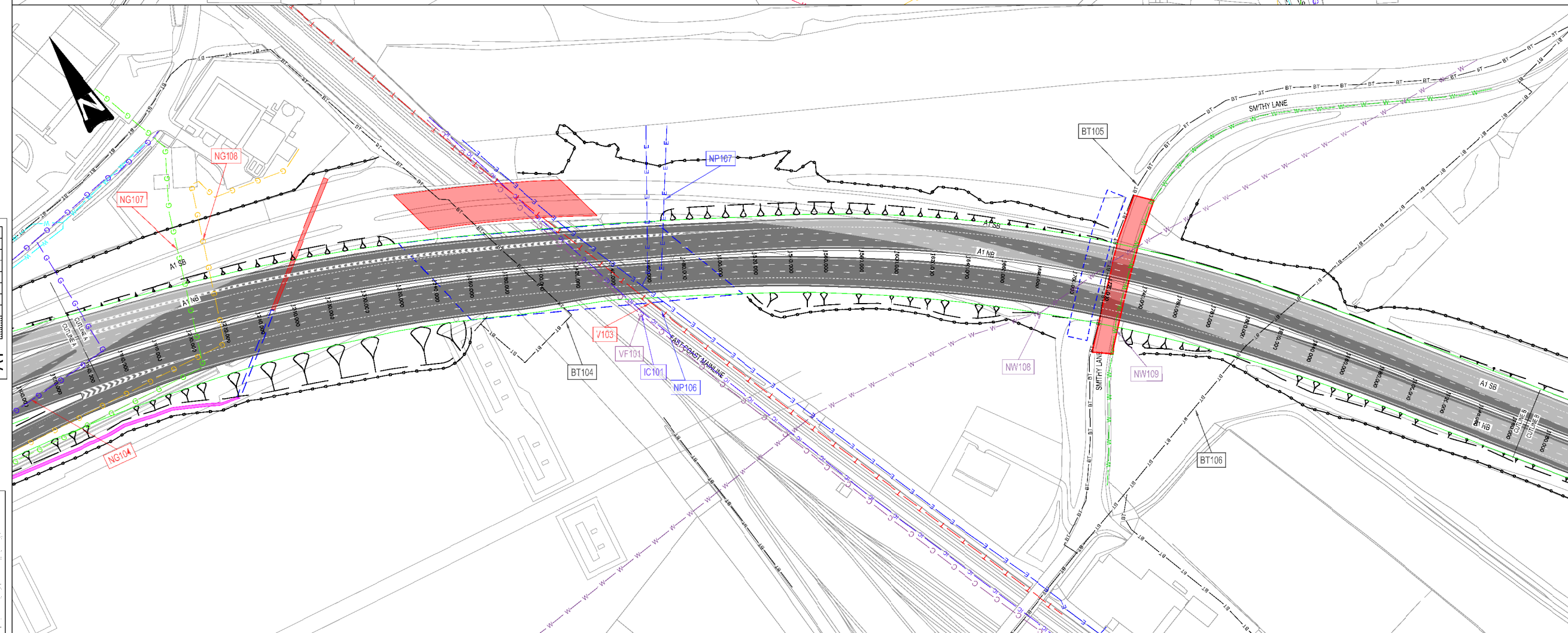
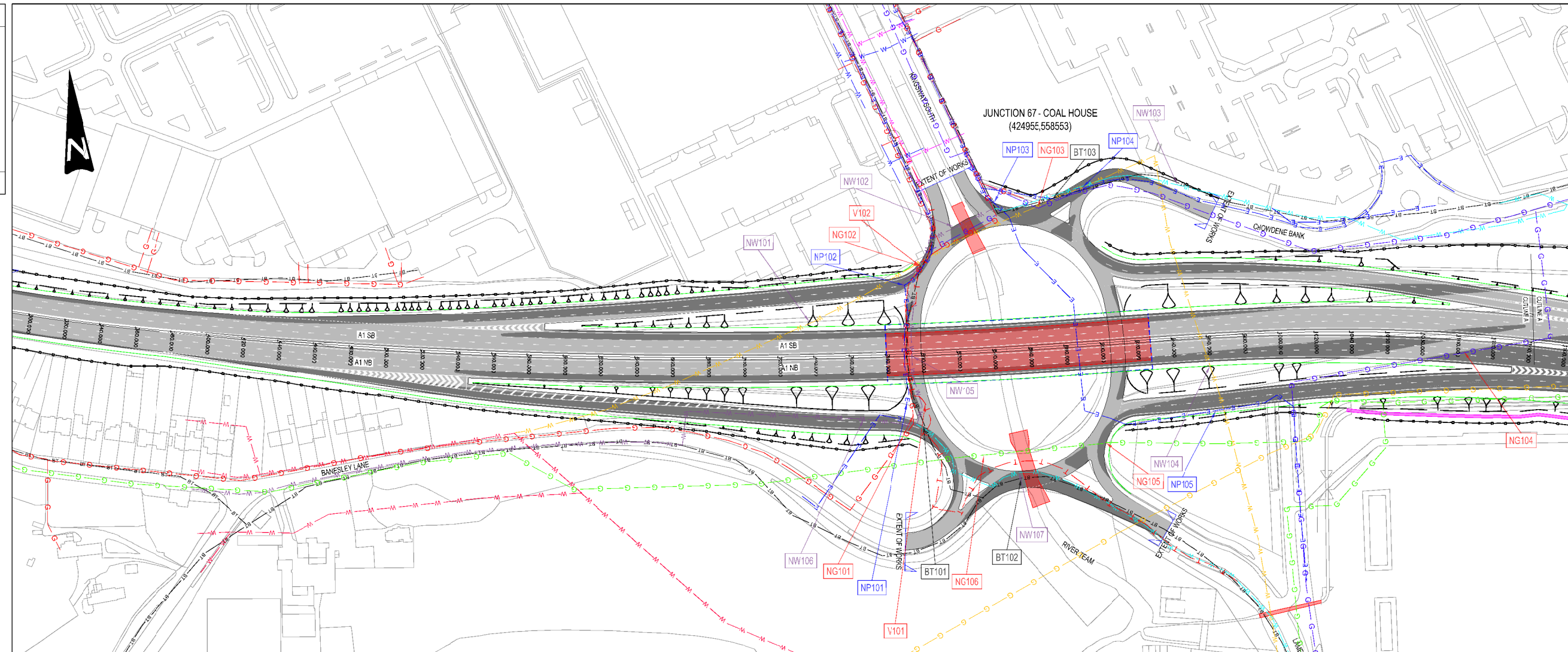

A1
DO NOT SCALE

Scale 1:1250
Date 06/01/2016
Drawing Number HA551462 - WSP - VUT - BCH - DR - D - 2700_026

NOTES

- LOCATION OF SERVICE PLANT SHOWN ON THIS DRAWING HAS BEEN OBTAINED FROM C2 STATUTORY UNDERTAKERS RETURNS AND IS SHOWN INDICATIVELY. THE STATUTORY UNDERTAKERS ARE TO SATISFY THEMSELVES OF THE LOCATION AND EXTENTS OF SERVICE PLANT.
- REFER TO SECTION 3.10 OF THE TECHNICAL APPRAISAL REPORT FOR DETAILS OF THE DIVERSION WORKS PROPOSED.

KEY

- BT — BT DUCT
- IC — INSTALCOM
- W — NORTHUMBRIAN WATER COMBINED
- W — NORTHUMBRIAN WATER FOUL
- W — NORTHUMBRIAN WATER ABANDONED
- W — NORTHUMBRIAN WATER SURFACE
- W — NORTHUMBRIAN WATER TREATED
- W — NORTHUMBRIAN WATER DISTRIBUTION
- W — NON NORTHUMBRIAN WATER PRIVATE
- G — NORTHERN GAS LOW PRESSURE
- G — NORTHERN GAS MEDIUM PRESSURE
- G — NORTHERN GAS INTERMEDIATE PRESSURE
- G — NORTHERN GAS REGIONAL HIGH PRESSURE
- T — VIRGIN MEDIA CABLE
- E — NORTHERN POWER GRID CABLE
- C — VODAFONE CABLE
- IC01 — UTILITY REFERENCE
- EXISTING STRUCTURE
- PROPOSED STRUCTURE
- PROPOSED HIGHWAYS FENCE LINE
- NEW CARRIAGEWAY CONSTRUCTION
- EXISTING CARRIAGEWAY TO BE RETAINED
- PROPOSED DRAINAGE DITCH
- PROPOSED SIGNAL
- EXISTING SIGNAL

Reproduced by permission of Ordnance Survey on behalf of HMSO. © Crown copyright and database right 2011. All rights reserved. Ordnance Survey Licence number 100016628

SAFETY, HEALTH AND ENVIRONMENTAL SYMBOL LEGEND

INDICATES A RESIDUAL RISK AS A WARNING

Rev	Date	Description	By	App
S2	08/01/2016	FOR INFORMATION	RA	COP NGR

Designer: **WSP PARSONS BRINCKERHOFF**
 Three White Rose Office Park, Millthorpe Park Lane, Leeds, LS11 0DL
 Tel: +44 (0)113 395 6200, Fax: +44 (0)113 395 6201
 http://www.wspgroup.com

Client: **highways england**

Project Title: **A1 BIRTLEY TO COAL HOUSE**

Drawing Title: **STATUTORY UNDERTAKERS OPTION 2 SHEET 1 OF 3**

Scale	Drawn	Designed	Checked	Approved	CR CODE
1:1250	LCB	IAK	COP	NGR	
Size	Date	Date	Date	Date	
A1	06/01/2016	08/01/2016	08/01/2016	08/01/2016	

Status: **FOR INFORMATION** Submittal: **S2**

Drawing Number: **HA551462 - WSP - VUT - BCH - DR - D - 2700_026** Revision: **P1.0**

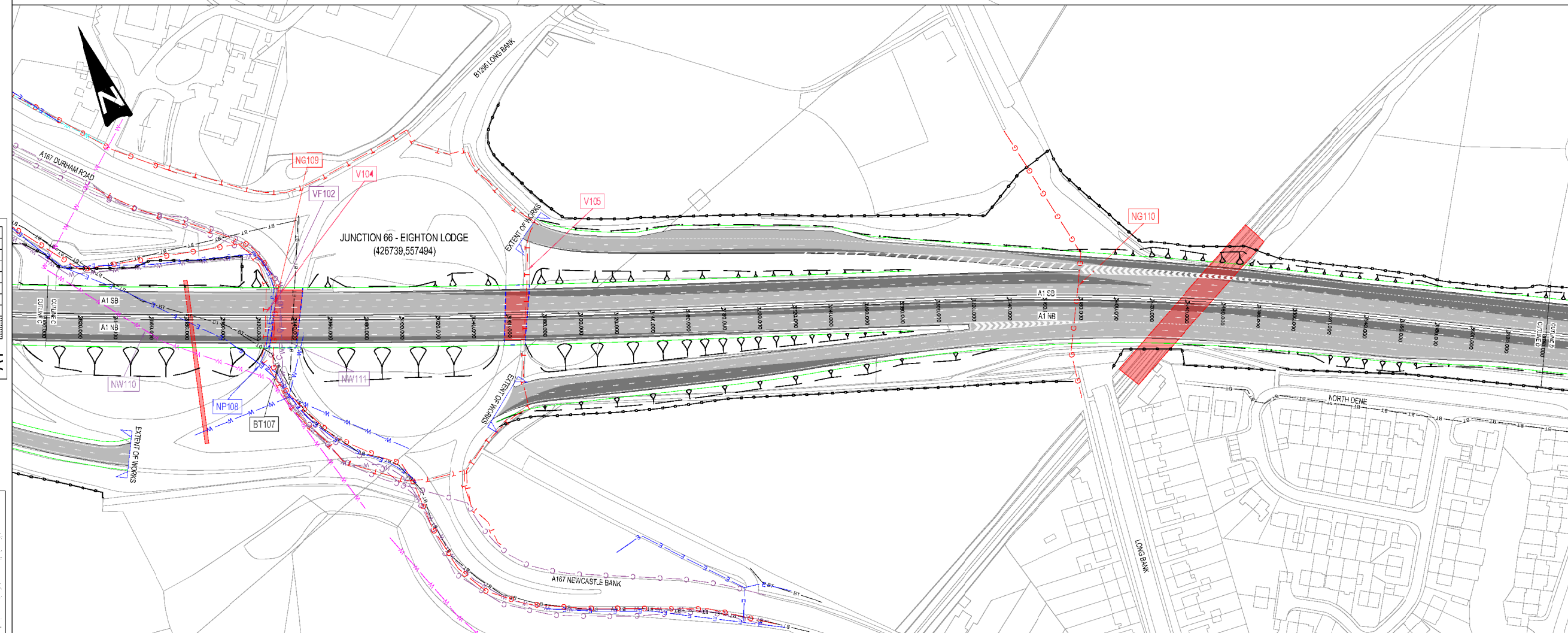
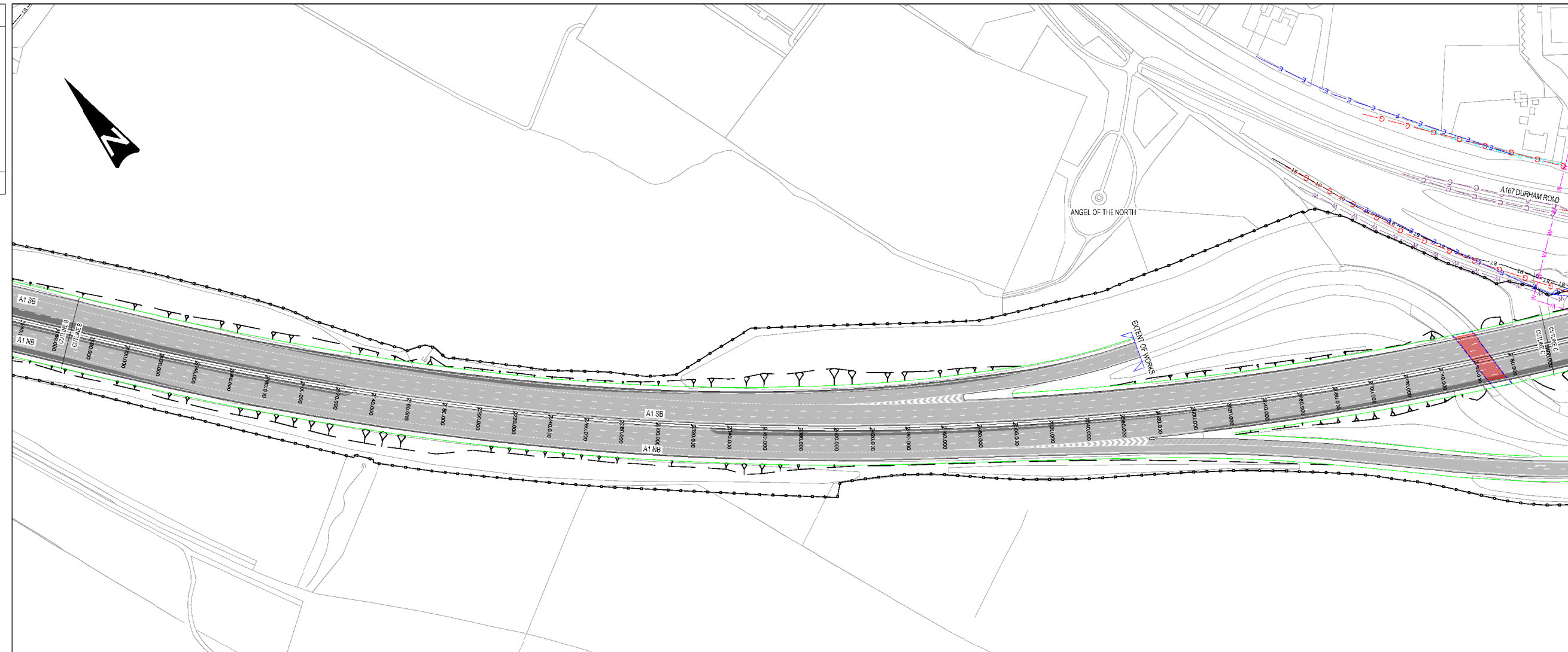

- NOTES**
- LOCATION OF SERVICE PLANT SHOWN ON THIS DRAWING HAS BEEN OBTAINED FROM CC STATUTORY UNDERTAKERS RETURNS AND IS SHOWN INDICATIVELY. THE STATUTORY UNDERTAKERS ARE TO SATISFY THEMSELVES OF THE LOCATION AND EXTENTS OF SERVICE PLANT.
 - REFER TO SECTION 3.10 OF THE TECHNICAL APPRAISAL REPORT FOR DETAILS OF THE DIVERSION WORKS PROPOSED.
- KEY**
- BT BT DUCT
 - IC INSTAL.COM
 - W W NORTHUMBRIAN WATER COMBINED
 - W W NORTHUMBRIAN WATER FOUL
 - W W NORTHUMBRIAN WATER ABANDONED
 - W W NORTHUMBRIAN WATER SURFACE
 - W W NORTHUMBRIAN WATER TREATED
 - W W NORTHUMBRIAN WATER DISTRIBUTION
 - W W NON NORTHUMBRIAN WATER PRIVATE
 - G G NORTHERN GAS LOW PRESSURE
 - G G NORTHERN GAS MEDIUM PRESSURE
 - G G NORTHERN GAS INTERMEDIATE PRESSURE
 - G G NORTHERN GAS REGIONAL HIGH PRESSURE
 - T T VIRGIN MEDIA CABLE
 - E E NORTHERN POWER GRID CABLE
 - C C VODAFONE CABLE
 - IC01 UTILITY REFERENCE
 - EXISTING STRUCTURE
 - PROPOSED STRUCTURE
 - PROPOSED HIGHWAYS FENCE LINE
 - NEW CARRIAGEWAY CONSTRUCTION
 - EXISTING CARRIAGEWAY TO BE RETAINED
 - PROPOSED DRAINAGE DITCH
 - PROPOSED SIGNAL
 - EXISTING SIGNAL

Reproduced by permission of Ordnance Survey on behalf of HMSO. © Crown copyright and database right 2011. All rights reserved. Ordnance Survey Licence number 100018629

SAFETY, HEALTH AND ENVIRONMENTAL SYMBOL LEGEND
 ⚠ INDICATES A RESIDUAL RISK AS A WARNING

Rev	Date	Description	By	App
01	08/01/2016	FOR INFORMATION	RA	COP NGR

WSP PARSONS BRINCKERHOFF
 Three White Rose Office Park, Millthorpe Park Lane, Leeds, LS11 0DL
 Tel: +44 (0)113 395 6200, Fax: +44 (0)113 395 6201
<http://www.wspgroup.com>

Client: **highways england**

Project Title: **A1 BIRTLEY TO COAL HOUSE**

Drawing Title: **STATUTORY UNDERTAKERS OPTION 2 SHEET 2 OF 3**

Scale	Drawn	Designed	Checked	Approved	CR CODE
1:1250	LCB	IAK	COP	NGR	S2
Size	Date	Date	Date	Date	Status
A1	06/01/2016	08/01/2016	08/01/2016	08/01/2016	FOR INFORMATION
Drawing Number	HA551462 - WSP - VUT - BCH - DR - D - 2700_027				Revision
					P1.0

A1

DO NOT SCALE

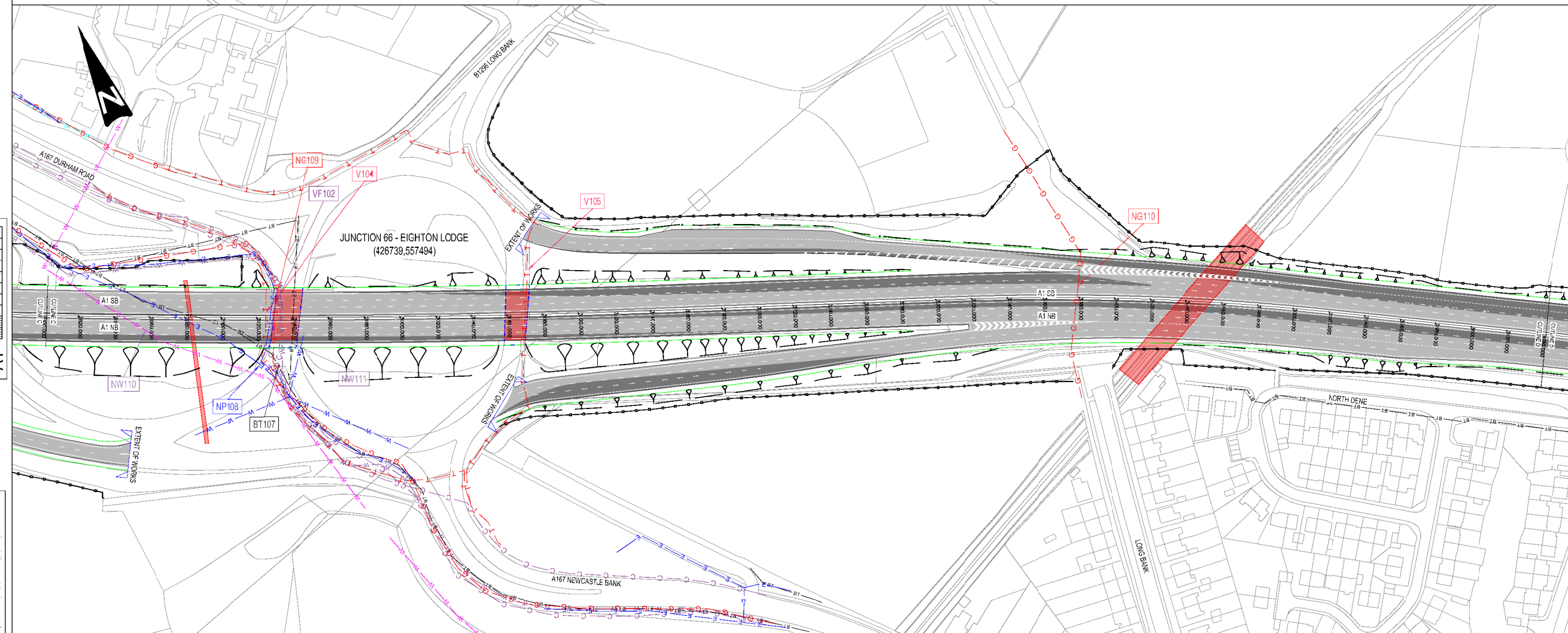
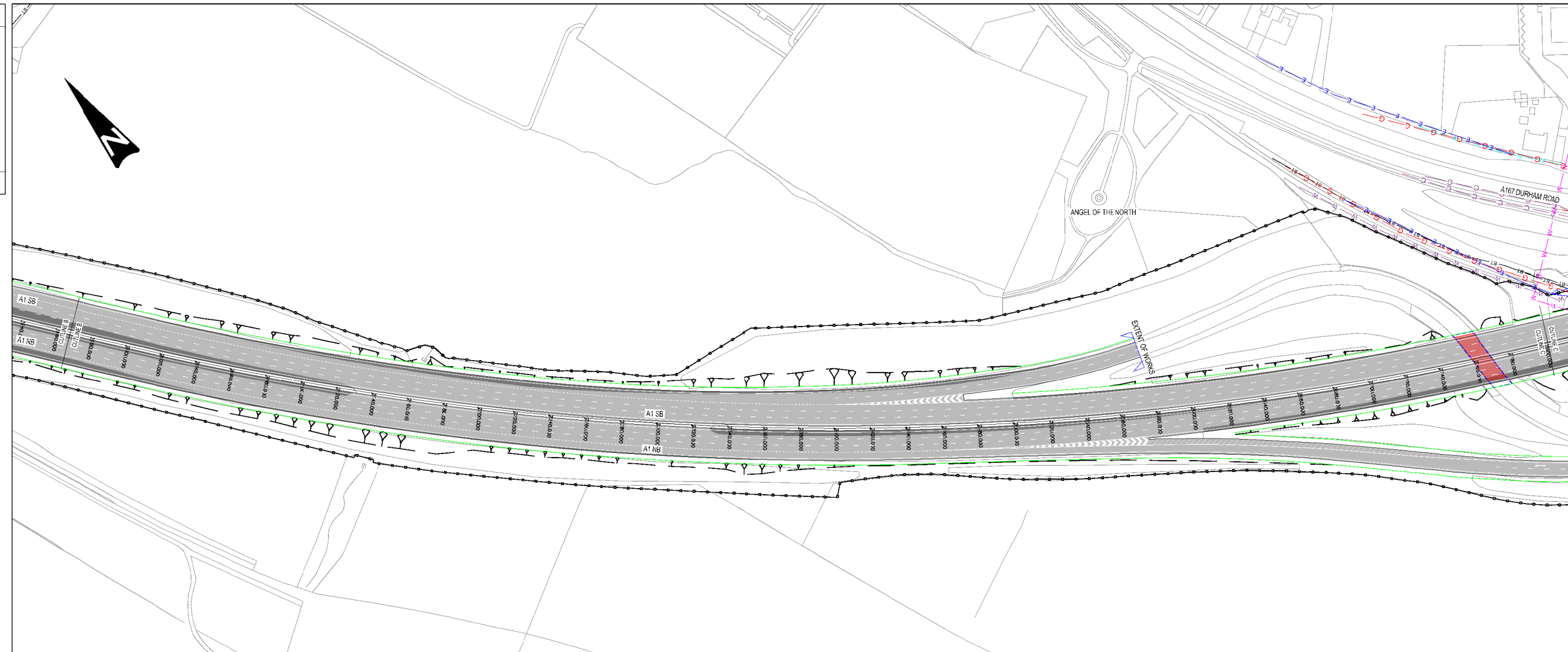

- NOTES**
- LOCATION OF SERVICE PLANT SHOWN ON THIS DRAWING HAS BEEN OBTAINED FROM CC STATUTORY UNDERTAKERS RETURNS AND IS SHOWN INDICATIVELY. THE STATUTORY UNDERTAKERS ARE TO SATISFY THEMSELVES OF THE LOCATION AND EXTENTS OF SERVICE PLANT.
 - REFER TO SECTION 3.10 OF THE TECHNICAL APPRAISAL REPORT FOR DETAILS OF THE DIVERSION WORKS PROPOSED.
- KEY**
- BT BT DUCT
 - IC INSTAL.COM
 - W W NORTHUMBRIAN WATER COMBINED
 - W W NORTHUMBRIAN WATER FOUL
 - W W NORTHUMBRIAN WATER ABANDONED
 - W W NORTHUMBRIAN WATER SURFACE
 - W W NORTHUMBRIAN WATER TREATED
 - W W NORTHUMBRIAN WATER DISTRIBUTION
 - W W NON NORTHUMBRIAN WATER PRIVATE
 - G G NORTHERN GAS LOW PRESSURE
 - G G NORTHERN GAS MEDIUM PRESSURE
 - G G NORTHERN GAS INTERMEDIATE PRESSURE
 - G G NORTHERN GAS REGIONAL HIGH PRESSURE
 - T T VIRGIN MEDIA CABLE
 - E E NORTHERN POWER GRID CABLE
 - C C VODAFONE CABLE
 - IC01 UTILITY REFERENCE
 - EXISTING STRUCTURE
 - PROPOSED STRUCTURE
 - PROPOSED HIGHWAYS FENCE LINE
 - NEW CARRIAGEWAY CONSTRUCTION
 - EXISTING CARRIAGEWAY TO BE RETAINED
 - PROPOSED DRAINAGE DITCH
 - PROPOSED SIGNAL
 - EXISTING SIGNAL

Reproduced by permission of Ordnance Survey on behalf of HMSO. © Crown copyright and database right 2011. All rights reserved. Ordnance Survey Licence number 100018629

SAFETY, HEALTH AND ENVIRONMENTAL SYMBOL LEGEND

INDICATES A RESIDUAL RISK AS A WARNING

Rev	Date	Description	Des	CHK	APP
SI	08/01/2016	FOR INFORMATION			

Designer: **WSP PARSONS BRINCKERHOFF**
 Three White Rose Office Park, Millthorpe Park Lane, Leeds, LS11 0DL
 Tel: +44 (0)113 395 6200, Fax: +44 (0)113 395 6201
 http://www.wspgroup.com

Client:		highways england	
Project Title:		A1 BIRTLEY TO COAL HOUSE	
Drawing Title:		STATUTORY UNDERTAKERS OPTION 2 SHEET 2 OF 3	
Scale:	1:1250	Drawn:	LCB
Date:	06/01/2016	Designed:	IAK
Date:	06/01/2016	Checked:	COP
Date:	06/01/2016	Approved:	NGR
Status:	FOR INFORMATION		CR CODE
Drawing Number:	HA551462 - WSP - VUT - BCH - DR - D - 2700_027		Revision:
			S2

Appendix E

MINUTES TO MEETING – NGN/WSP PB

Appendix E-1

MINUTES TO MEETING - NGN/WSP PB

**A1B2CH meeting with Northern Gas
Tuesday 24th January 2017 (10am – 11am)
Whitby meeting room, HE offices, Lateral, Leeds**

Meeting Notes

Attendees:

Highways England (HE) – [REDACTED]

WSP|PB – [REDACTED]

Northern Gas Networks (NGN) – [REDACTED]
[REDACTED]

1. Introductions were made. [REDACTED] and [REDACTED] provided an update of the scheme.
2. Highways England are looking to appoint a statutory undertakers lead who will provide support to all projects as the scheme moves forward. [REDACTED] (Gattica) is currently undertaking this role on a temporary basis but was unable to attend the meeting.
3. The current scheme programme states that start of works will be in March 2020, at which point the NGN diversionary works would commence. There is a potential efficiency of undertaking the diversions as advanced works during PCF Stage 5 in 2019 which would bring forward the start of the main construction works.
4. [REDACTED] confirmed that the diversion works would ideally be completed in the summer months but suggested it would also be possible to complete the work in the spring or autumn. This is due to the heavy demand on the gas network during the winter months and the inability to recalibrate the network at this time.
5. Planning, preparation and procurement for the works would take place in the first year following the commitment to a C4 estimate, with a view to complete construction in the following year. It takes approximately 9 to 12 months to purchase the necessary materials following the completion of the detailed design. The scheme Preferred Route Announcement (PRA) is scheduled for summer 2017, at which point funding for the next Stage of works will be available and the C4 estimate will be able to be procured. On this basis, undertaking the diversion works in summer 2019 would be achievable providing the C4 estimate is procured by autumn 2017. NGN stated that the diversion works for Option 1a would take approximately 36 weeks and Option 1b would take 52 weeks based on the previously provided estimate (December 2016).
6. It was stated that the scheme is currently assumed to be subject to a Development Consent Order (DCO). [REDACTED] advised that the team will need clarification on whether the works undertaken by NGN can go ahead under the New Roads and Street Works Act (NRSWA) 1991 powers outside of the DCO process.
7. The pressure reduction station (PRS) situated to the northwest of Allerdene Railway Bridge is a critical part of infrastructure to supply gas to the North East area. The PRS only has one high pressure pipe feeding into it which would require a diversion before construction began on either of the options that HE are currently assessing.

8. NGN stated that they have produced two diversion proposals for Option 1a and one proposal for Option 1b. One of the proposals for Option 1a and the Option 1b proposal include the relocation of the PRS to the south of the highway alignment. The other proposal for Option 1a involves the diversion of the gas mains that cross the A1 between Allerdene Bridge and Coal House interchange.
9. NGN stated that they would undertake a design study focussed on one option for the C4 estimate which would have an upfront cost of approximately £100k. A firm request for the C4 estimate would have to be submitted prior to any design works taking place as per NRSWA guidance. The design study and C4 estimate would take approximately six months. ■■■ advised that following the design study, a quote to deliver the diversion works would then be provided. This is currently expected to be approximately £4.9m for Option 1a and £10m for Option 1b. HE would then have 90 days to accept the quote. The figure stated at this time would be subject to change due to unforeseen issues which can occur during development that may impact the final cost. The project team would have to factor in the cost of risk for variances that may come up whilst NGN are undertaking the works. The NGN team advised that they would be happy to attend scheme risk workshops whilst in the design phase to identify possible risks and assist in the risk management process.
10. ■■■ stated that the C4 estimate and design study cost is non-refundable. ■■■ also advised that should the scheme stop for any reason prior to the diversionary works starting, the quote for the works would not need to be paid. It was stated that there would be an 18% discount for the works as set out in NRSWA. There could also be the potential for a contribution to the works from NGN as part of long term improvement plans for the PRS. ■■■ advised that the already planned PRS improvement works are required to future proof the gas network so it would be prudent to combine the NGN works with the HE scheme to ensure there are no design conflicts or rework.
11. It was stated that the land to the southwest of Allerdene Railway Bridge where the decommissioned gas governor site is located is owned by NGN. NGN stated that all the buried pipe have been removed from this storage facility and would be the ideal location for their site compound. The project team had already identified this area as a site compound for the HE scheme; therefore this could be handed over once NGN have concluded their works. This is something that the project team will consider whilst liaising with contractors ahead of construction works.
12. Next steps:
 - ■■■ to have further discussions with the project board and Senior Responsible Owner regarding the approval for undertaking the diversions as advanced works and funding for the C4 procurement.
 - WSP to send updated General Arrangements to NGN with programme showing NGN time constraints as discussed.
 - NGN to send through updated diversion proposals to HE.
 - Further meeting to be organised prior to summer to discuss options for moving forward.

MEETING NOTES

Job Title	A1 Birtley to Coal House (A1B2CH)
Project Number	70015226
Date	13 March 2017
Time	Meeting time 10:00 to 12:00
Venue	WSP PB Leeds Office, White Rose meeting room
Subject	Northern Gas Update
Client	Highways England
Present	<p>Highways England (HE) [REDACTED] – Project Manager WSP PB [REDACTED] – Project Manager [REDACTED] – Assistant Project Manager [REDACTED] – Principal Designer Northern Gas Networks (NGN) [REDACTED] Costain [REDACTED]</p>
Apologies	<p>Highways England - WSP PB -</p>
Distribution	<p>As above plus: Highways England – [REDACTED] (Gattica) WSP PB –</p>

Three White Rose Office Park
 Millshaw Park Lane
 Leeds
 LS11 0DL

Tel: +44 (0) 113 395 6200
 Fax: +44 (0) 113 395 6201

www.wspgroup.com
www.pbworld.com

MATTERS ARISING

ACTION

0.0 INTRODUCTION

0.1 Introductions were made. [REDACTED] explained that his involvement in the scheme is to provide buildability advice to HE and WSP|PB.

1.0 SITE INFORMATION

1.1 NGN stated that the existing gas pumping station situated to the north of the A1 adjacent to Allerdene Bridge currently has one intermediate pressure gas main feeding in. This is then distributed to most of the Gateshead, Newcastle and Sunderland area via regional high pressure, intermediate pressure and medium pressure mains. These three mains which leave the gas pressure reduction station (PRS) all cross beneath the A1.

1.2 NGN stated that as part of their upgrade programme, they would be looking to build a new site to replace the existing PRS. Following the construction of a new PRS, the existing site would be decommissioned, demolished and the land would be possibly sold. Land sale is deemed not to be critical to the success of NGN schemes, given the potential difficulty of sale due to detrimental environment affects to the land surrounding the site.

1.3 The plot of land to the south of the A1 and the west of the East Coast Mainline where the proposed gas site is to be relocated to, will also be used as a site compound with the potential of HE reusing the site for their works. This plot of land is owned by NGN who currently grant permission to a local stable to use the field to run horses.

2.0 PROPOSED OPTION

- 2.1 NGN have provided two options for the diversion works on HE Option 1a and one option for Option 1b. As Option 1a is deemed the preferred HE option, the two NGN options being considered consist of either decommissioning the existing mains which cross the A1 and new mains to be laid to accommodate the proposed highway alignment. The other option is to relocate the PRS to the south of the A1 meaning only one low pressure main will cross beneath the A1, which is NGN's preferred solution. The two options cost approximately £5M and £7M respectively.
- 2.2 NGN intend on upgrading the site irrespective of the HE scheme and would contribute funding to the diversion works, which has already been deducted from the figures stated above. The benefit to HE to relocate the PRS for an additional £2M was queried. NGN stated that the three mains crossing the A1 would be replaced to one low pressure main, and there could be potential cost savings when using the NGN plot of land for the site compound.
- 2.3 NGN stated that they are flexible on the location of the proposed PRS and main crossings under the A1 as they cross approximately 11m below carriageway level.

3.0 PLANNING AND PROGRAMME

- 3.1 NGN stated that the detailed design would take 5-6 months following procurement of the C4 detailed estimate and would include a full costing for the materials and construction works. It was stated that should the C4 be procured by mid-April, NGN would intend to have completed the design and costings by the end of 2017.
- 3.2 With regards to the planning process, it was stated that the NGN diversion works would be outside of the HE scheme Development Consent Order (DCO). The works would still require planning given the scale and the surrounding residential areas, however the proposed site is still located within NGN land and all works would take place within either NGN or HE land so the risk of planning consent being refused was deemed to be low.
- 3.3 As there are planning aspects for both schemes, it was agreed that communications are to be aligned to ensure a consistent message is delivered to key stakeholders and members of the public during public consultations.
- 3.4 Both schemes will require a ground investigation; therefore there would be a possible efficiency by combining the works into one.
- 3.5 It was stated that there is approximately a 40 week lead time for ordering materials given there are only two approved foundries in Europe.
- 3.6 NGN stated that to construct Option 1c, where the PRS is relocated to the south of the A1, they would allow approximately nine months. Given the demand on the gas supply over the winter months, it was stated that the high pressure main and the PRS would not be diverted outside the months from April to October. The lower pressure mains would be able to be diverted during the winter months and the PRS would be able to be constructed prior to the actual diversion works.
- 3.7 NGN would require the construction budget from HE by December 2018 to enable construction procurement by January 2019 and construction start by April 2019.
- 3.8 NGN stated that in the event of the HE scheme being delayed, they would be able to shelve their works for two years. Should the delay be any longer, NGN would intend on upgrading the site irrespective of the HE scheme introducing a risk of rework once the HE scheme is constructed.

4.0 BUDGET

- 4.1 The C4 detailed estimate is to be paid for in advance of the design work and will

Meeting Notes

MATTERS ARISING

cost £100K.

- 4.2 HE would use advanced funding from the construction phase budget to pay for the NGN works.

5.0 ANY OTHER BUSINESS

- 5.1 NGN may require to have a representative on site during construction to ensure all works avoid the diverted mains.

ACTION

6.0 ACTIONS LIST

1) ■ to prepare a programme based on the assumptions provided in this meeting.	■
2) Programme to be sent to ■ for NGN comments.	■
3) NGN to commence preparing requirements document and scope.	NGN
4) NGN to contact ■ to explain details around the site compound.	NGN
5) Latest General Arrangement drawings are to be sent to NGN.	WSP PB



MEETING NOTES

JOB TITLE	A1 Birtley to Coal House
PROJECT NUMBER	70015226
DATE	18 May 2017
TIME	14:00 – 16:00
VENUE	Highways England, Lateral (Whitby)
SUBJECT	A1B2CH Northern Gas Networks Update Meeting
CLIENT	Highways England
PRESENT	Highways England [REDACTED] – <i>Project Manager</i> [REDACTED] – <i>Stats Lead</i> WSP [REDACTED] – <i>Assistant Project Manager</i> [REDACTED] – <i>Highways Design Lead</i> NGN [REDACTED] [REDACTED] [REDACTED] [REDACTED] Costain [REDACTED]
APOLOGIES	WSP [REDACTED] – <i>Project Manager</i>
DISTRIBUTION	All attendees and apologies.

MATTERS ARISING

ACTION

1.0 INTRODUCTION	
1.1 Introductions were made.	
2.0 GENERAL	

MEETING NOTES

2.1	NGN confirmed that their preferred option will be the relocation of the Above Ground Infrastructure (AGI) to the south of the A1, rather than the diversion of the three mains which cross the A1.	
2.2	NGN stated that Ground Investigation (GI) would be required where the proposed AGI is to be relocated. The A1B2CH scheme is currently procuring a GI, [REDACTED] is to send through plans to [REDACTED] showing the current proposed borehole locations. MU to provide specification for NGN GI works including borehole locations. It was stated that the gas site in the field where the proposed AGI is to be located was only used as a gas storage facility and is currently not expected to contain any contaminated land. It was also noted that the site was decommissioned in circa 1983/84	[REDACTED]
2.3	NGN intend to tender the design for the works to sub-consultants from their preferred suppliers framework. Highways England would have to approve these suppliers prior to the tender process commencing.	
2.4	NGN stated that any decommissioned gas mains crossing the A1 will be grouted as part of the works.	[REDACTED]
2.5	[REDACTED] is to send C2 stats returns drawings to NGN.	[REDACTED]
3.0	PROGRAMME	
3.1	[REDACTED] stated that the C4 detailed estimate will be procured by Highways England within June 2017 and the cost of this was confirmed to be £100k.	[REDACTED]
3.2	NGN stated that the detailed design would be available by the end of 2017. [REDACTED] raised that there is an Investment Decision Committee (IDC) taking place on the 2/11/17 with a follow up Highways England Board (HEB) meeting on the 29/11/17. NGN stated that they could produce a conceptual design by September in order to meet the Highways England Investment Submission date six weeks prior to IDC. This will allow an accurate figure of funding to be requested. Following the IDC and HEB meetings, Highways England would then pay for the procurement of the materials which is expected to be approximately 50% of the overall budget.	
3.3	NGN stated that the lead in time for the manufacturing of the AGI would be approximately 40 weeks, and for the pipes it would be approximately 20 – 24 weeks.	
3.4	NGN noted that HSE require a 12 month notification prior to the start of any works of this nature.	
3.5	The current intention of NGN is to commence construction in January 2019 and to complete the works by October 2019. This would include all the gas pipe connections taking place in the summer of 2019. It was stated that the AGI could commence construction prior to January 2019 to ensure there is no slippage of programme beyond October 2019.	
4.0	RISK	
4.1	[REDACTED] raised the following risks from a NGN perspective: <ul style="list-style-type: none">– The quote of £100k (exc. VAT) for producing the C4 detailed design is too low and additional budget is required.– Land required to undertake the diversions is unavailable.– Planning permission is not granted for the relocation of the PRS.– Highways England shelve or scrap the scheme at key phases of NGN programme.– Highways England payment when procuring materials or construction costs is late affecting the programme.– Should the programme slip, the costs of construction during winter months is much higher than the rest of the year.– The different pressure gas pipes crossing the A1 are managed by separate teams, therefore there is a risk of miscommunication between design teams.– Ground Investigation and Environmental surveys will be required, risk of re-work between both organisations. There is also a risk of not gaining access to private land to undertake surveys.– Diversion works could have a conflict with the re-aligned Allerdene Brook.– Clashes with other utilities.– Network Rail access track to Allerdene Bridge. Need a temporary and permanent	

MEETING NOTES

	replacement with approval from Network Rail.	
5.0	PLANNING	
5.1	NGN queried whether the planning process for the diversion works could be combined with the A1B2CH DCO. [REDACTED] stated that this won't be possible as the DCO won't be made until March 2020, following the completion of the diversion works according to the current programme. The NGN works will have to go through a separate planning process.	
5.2	Once NGN have produced their conceptual design, the planning process for the works will commence.	
5.3	To ensure an efficient planning process, the planning teams from both project teams are to liaise to ensure communications to any land owners is consistent.	
5.4	[REDACTED] stated that the land owner to the south of the NGN land, south of the A1, could potentially object to having a site compound adjacent to his land. This is to be considered when moving forward in the planning process for the scheme.	
6.0	ACTIONS LIST	
1	[REDACTED] to procure C4 Detailed Design and Estimate.	[REDACTED]
2	[REDACTED] is to send through plans to MU showing the current proposed borehole locations.	[REDACTED]
3	[REDACTED] to provide specification for NGN GI works including borehole locations.	[REDACTED]
4	[REDACTED] to send C2 stats returns plans to NGN.	[REDACTED]

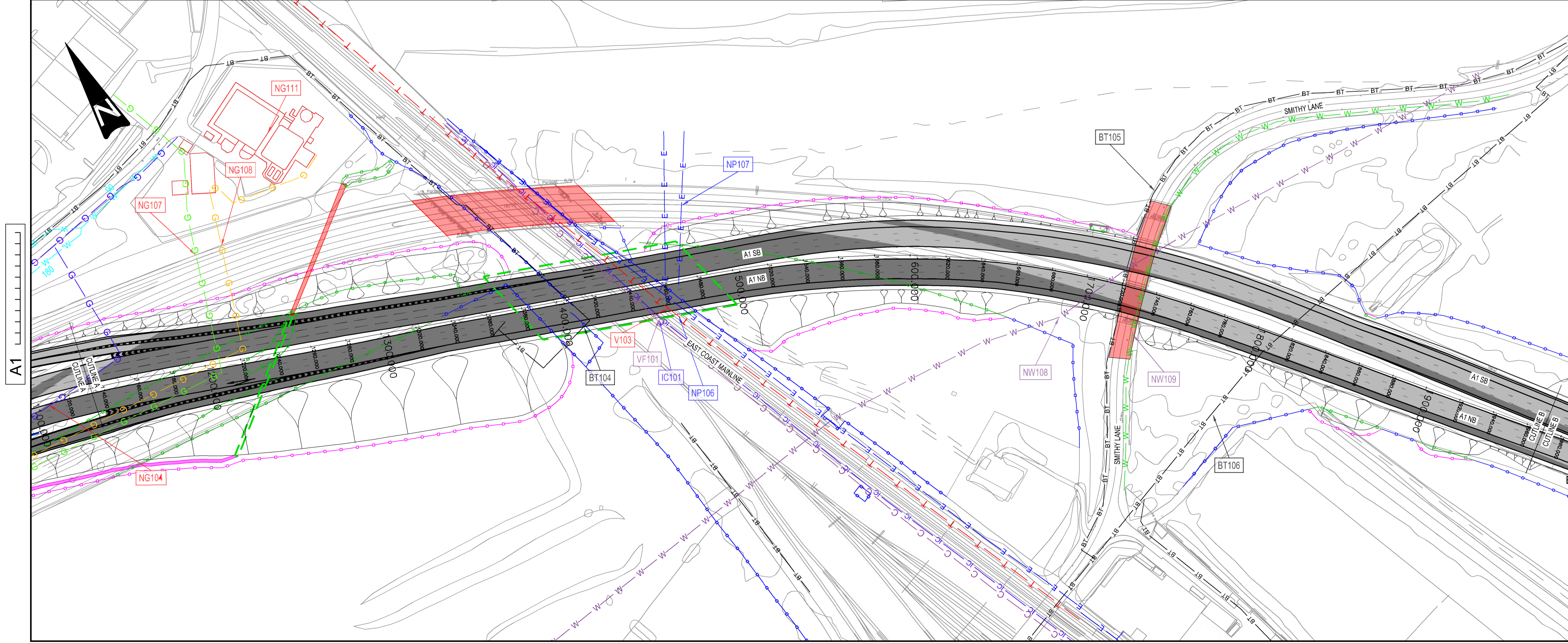
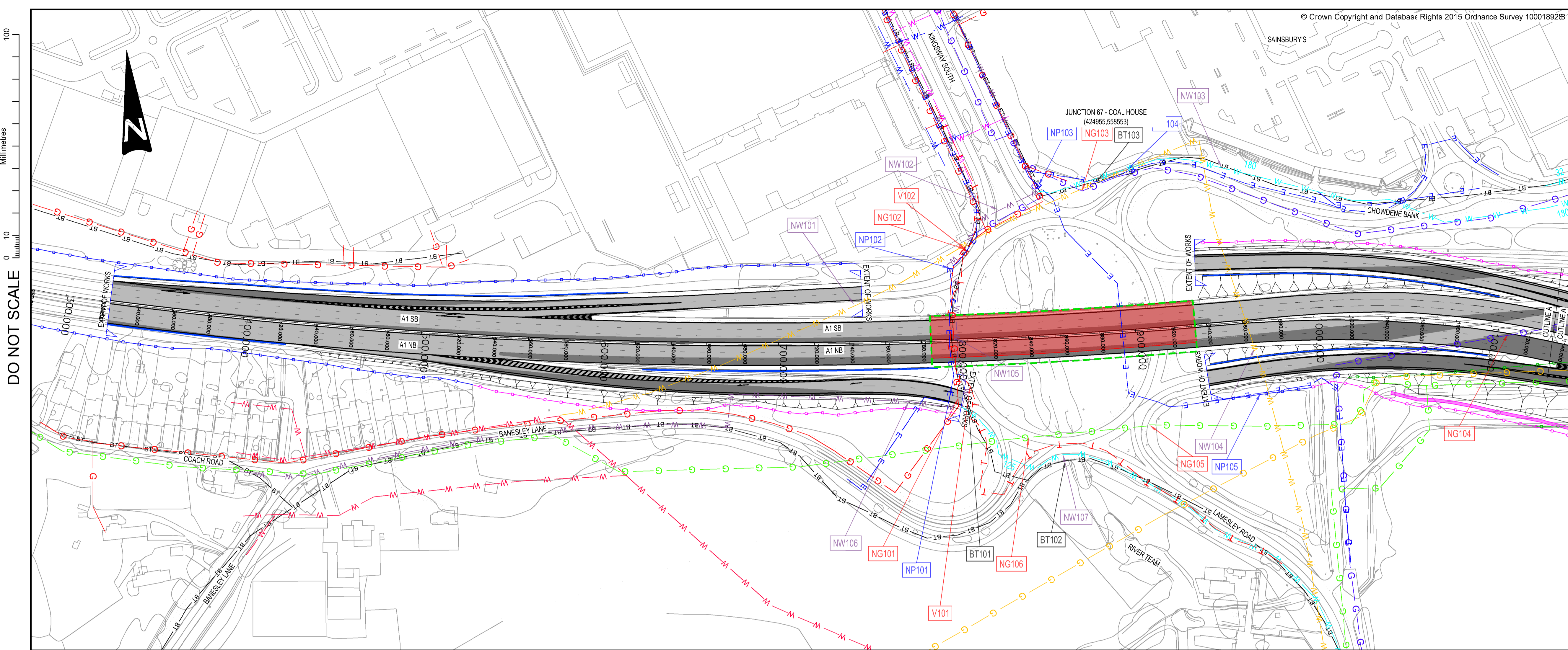

DO NOT SCALE

A1

KEY	
	EXISTING STRUCTURE
	PROPOSED STRUCTURE
	PROPOSED RETAINING WALL
	PROPOSED HIGHWAYS FENCE LINE
	EXISTING HIGHWAYS FENCE LINE
	NEW CARRIAGEWAY CONSTRUCTION
	EXISTING CARRIAGEWAY TO BE RETAINED
	PROPOSED DRAINAGE DITCH
	PROPOSED FOOTPATH DIVERSION
	EXISTING FOOTPATH
	BT DUCT
	INSTALCOM
	NORTHUMBRIAN WATER COMBINED
	NORTHUMBRIAN WATER FOUL
	NORTHUMBRIAN WATER ABANDONED
	NORTHUMBRIAN WATER SURFACE
	NORTHUMBRIAN WATER TREATED
	NORTHUMBRIAN WATER DISTRIBUTION
	NON NORTHUMBRIAN WATER PRIVATE
	NORTHERN GAS LOW PRESSURE
	NORTHERN GAS MEDIUM PRESSURE
	NORTHERN GAS INTERMEDIATE PRESSURE
	NORTHERN GAS REGIONAL HIGH PRESSURE
	VIRGIN MEDIA CABLE
	NORTHERN POWER GRID CABLE
	VODAFONE CABLE
	UTILITY REFERENCE

- NOTES**
1. LOCATION OF SERVICE PLANT SHOWN ON THIS DRAWING HAS BEEN OBTAINED FROM CC STATUTORY UNDERTAKERS RETURNS AND IS SHOWN INDICATIVELY. THE STATUTORY UNDERTAKERS ARE TO SATISFY THEMSELVES OF THE LOCATION AND EXTENTS OF SERVICE PLANT.
 2. REFER TO SECTION 3.10 OF THE TECHNICAL APPRAISAL REPORT FOR DETAILS OF THE DIVERSION WORKS PROPOSED.
 3. ALL DIAMETERS OF WATER MAINS ARE MEASURED IN MILLIMETERS UNLESS OTHERWISE STATED.

IMPORTANT WARNING

THE INFORMATION CONCERNING THE LOCATION AND/OR DEPTH OF THE PUBLIC UTILITY APPARATUS IS PROVIDED ON THIS DRAWING AS AN INDICATIVE GUIDE ONLY. NO GUARANTEE AS TO THEIR CORRECTNESS IS GIVEN OR IMPLIED.

THESE DRAWINGS SHOULD NOT BE RELIED UPON IN THE EVENT OF EXCAVATIONS OR OTHER WORKS MADE NEAR TO THE APPARATUS, WHICH MAY EXIST AT VARIOUS DEPTHS AND MAY DEVIATE FROM THE MARKED ROUTE. IT SHOULD ALSO BE NOTED THAT A SINGLE LINE SHOWN ON THE PLAN MAY INDICATE THE PRESENCE OF MORE THAN ONE CABLE.

THE CONTRACTOR IS REQUIRED TO ENSURE THAT THE LOCATIONS OF BELOW GROUND SERVICES ARE ESTABLISHED/CONFIRMED ON SITE PRIOR TO ANY EXCAVATIONS OR OTHER WORKS WHICH MAY AFFECT THE EXISTING SERVICES.

PRIOR TO ANY WORKS ON SITE, THE CONTRACTOR SHALL REFER TO:
 H5147 - AVOIDING DANGER FROM UNDERGROUND SERVICES (BY HSE)
 H5185 - HEALTH & SAFETY IN EXCAVATIONS (BY HSE)
 CONSTRUCTION INFORMATION SHEET (CIS) 4 - SAFETY IN EXCAVATIONS (BY HSE)
 GENERAL SERIES (GS) 6 - AVOIDANCE OF DANGER FROM OVERHEAD ELECTRIC LINES (BY HSE)

Rev.	Date	Description	By	Chk'd	App'd
	22/05/17				
P01	22/05/17	JSM/1	J.S	SG	NGR
P02	23/05/17	Design update, N2011 added	J.S	SG	NGR

WSP Three White Rose Office Park, Millshaw Park Lane, Leeds, LS11 0DL
 Tel: +44 (0)113 395 6200

PARSONS BRINCKERHOFF

© WSP UK Ltd www.wsp-pb.com

Client **Working on behalf of**

Project Title **A1 BIRTLEY TO COALHOUSE**

Drawing Title **OPTION 1A - OFFLINE REPLACEMENT OF ALLERDENE RAILWAY BRIDGE EXISTING STATUTORY UNDERTAKERS APPARATUS SHEET 1 OF 3**

Scale	1:1250	Drawn	J.Singh	Checked	S.Ghosh	Approved	N.Rawcliffe	Authorised	---
Original Size	A1	Date	23/05/17	Date	23/05/17	Date	23/05/17	Date	---
Drawing Status	INITIAL STATUS OR WIP								S0
Drawing Number	HE551462	Project	BCH	Originator	WSP	Volume	VUT	Project Ref. No.	
Location	DR	Type	D	Role	00001	Number		Revision	P02

DO NOT SCALE

Millimetres

0 10 100

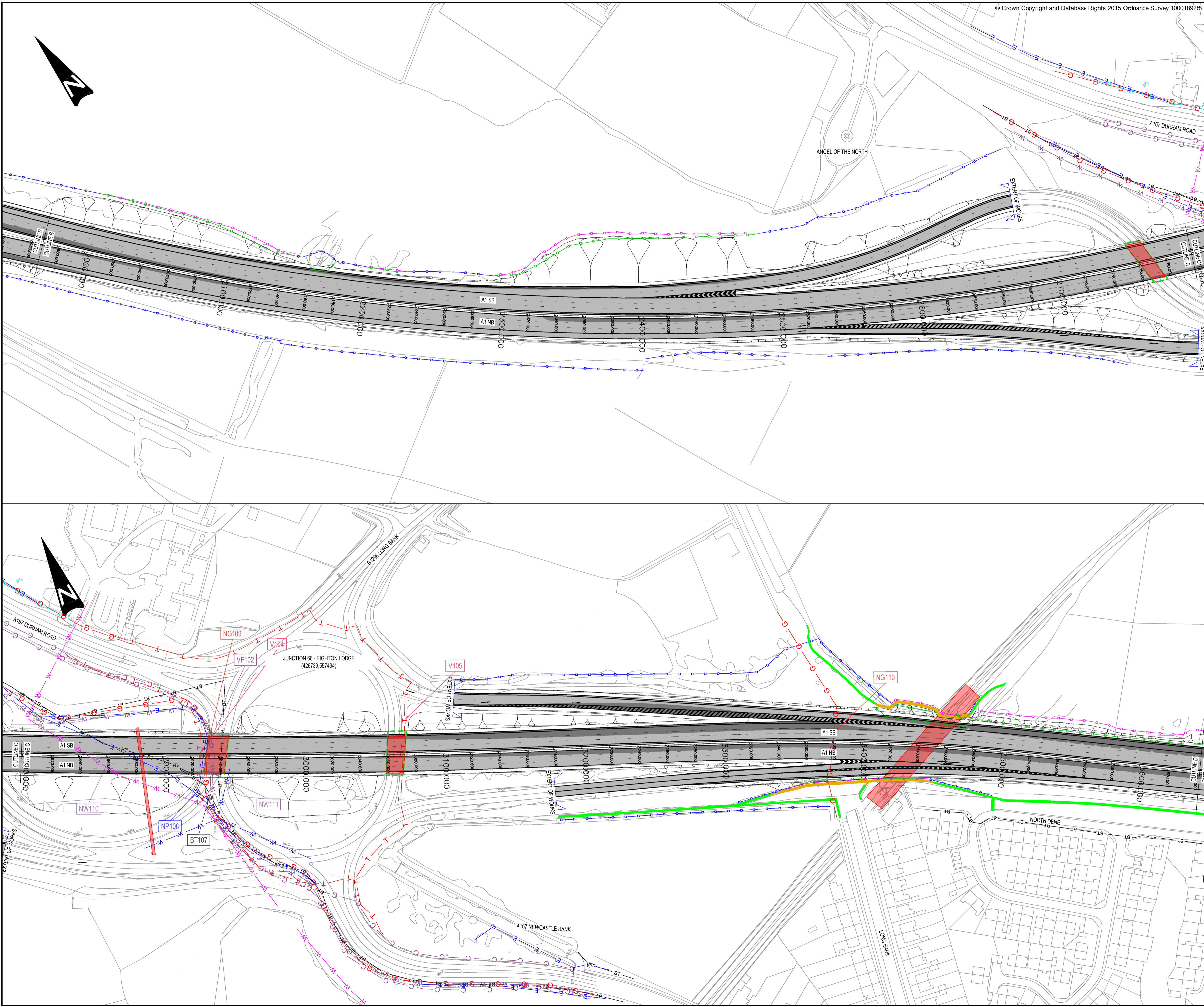

© Crown Copyright and Database Rights 2015 Ordnance Survey 100018928

KEY

- EXISTING STRUCTURE
- PROPOSED STRUCTURE
- PROPOSED RETAINING WALL
- PROPOSED HIGHWAYS FENCE LINE
- EXISTING HIGHWAYS FENCE LINE
- NEW CARRIAGEWAY CONSTRUCTION
- EXISTING CARRIAGEWAY TO BE RETAINED
- PROPOSED DRAINAGE DITCH
- PROPOSED FOOTPATH DIVERSION
- EXISTING FOOTPATH
- BT DUCT
- INSTALCOM
- NORTHUMBRIAN WATER COMBINED
- NORTHUMBRIAN WATER FOUL
- NORTHUMBRIAN WATER ABANDONED
- NORTHUMBRIAN WATER SURFACE
- NORTHUMBRIAN WATER TREATED
- NORTHUMBRIAN WATER DISTRIBUTION
- NON NORTHUMBRIAN WATER PRIVATE
- NORTHERN GAS LOW PRESSURE
- NORTHERN GAS MEDIUM PRESSURE
- NORTHERN GAS INTERMEDIATE PRESSURE
- NORTHERN GAS REGIONAL HIGH PRESSURE
- VIRGIN MEDIA CABLE
- NORTHERN POWER GRID CABLE
- VODAFONE CABLE
- UTILITY REFERENCE

NOTES

- LOCATION OF SERVICE PLANT SHOWN ON THIS DRAWING HAS BEEN OBTAINED FROM C2 STATUTORY UNDERTAKERS RETURNS AND IS SHOWN INDICATIVELY. THE STATUTORY UNDERTAKERS ARE TO SATISFY THEMSELVES OF THE LOCATION AND EXTENTS OF SERVICE PLANT.
- REFER TO SECTION 3.10 OF THE TECHNICAL APPRAISAL REPORT FOR DETAILS OF THE DIVERSION WORKS PROPOSED.
- ALL DIAMETERS OF WATER MAINS ARE MEASURED IN MILLIMETERS UNLESS OTHERWISE STATED.

IMPORTANT WARNING

THE INFORMATION CONCERNING THE LOCATION AND/OR DEPTH OF THE PUBLIC UTILITY APPARATUS IS PROVIDED ON THIS DRAWING AS AN INDICATIVE GUIDE ONLY. NO GUARANTEE AS TO THEIR CORRECTNESS IS GIVEN OR IMPLIED.

THESE DRAWINGS SHOULD NOT BE RELIED UPON IN THE EVENT OF EXCAVATIONS OR OTHER WORKS MADE NEAR TO THE APPARATUS, WHICH MAY EXIST AT VARIOUS DEPTHS AND MAY DEVIATE FROM THE MARKED ROUTE. IT SHOULD ALSO BE NOTED THAT A SINGLE LINE SHOWN ON THE PLAN MAY INDICATE THE PRESENCE OF MORE THAN ONE CABLE.

THE CONTRACTOR IS REQUIRED TO ENSURE THAT THE LOCATIONS OF BELOW GROUND SERVICES ARE ESTABLISHED/CONFIRMED ON SITE PRIOR TO ANY EXCAVATIONS OR OTHER WORKS WHICH MAY AFFECT THE EXISTING SERVICES.

PRIOR TO ANY WORKS ON SITE, THE CONTRACTOR SHALL REFER TO:
 HSC47 - AVOIDING DANGER FROM UNDERGROUND SERVICES (BY HSE)
 HSE185 - HEALTH & SAFETY IN EXCAVATIONS (BY HSE)
 CONSTRUCTION INFORMATION SHEET (CIS) 4 - SAFETY IN EXCAVATIONS (BY HSE)
 GENERAL SERIES (GS) 6 - AVOIDANCE OF DANGER FROM OVERHEAD ELECTRIC LINES (BY HSE)

22/05/17					
P01	22/05/17	JHM/T	J.S	SG	NGR
P02	23/05/17	Design update, NDR 111 added	J.S	SG	NGR
Rev.	Date	Description	By	Chk'd	App'd

WSP Three White Rose Office Park, Millshaw Park Lane, Leeds, LS11 0DL
 Tel: +44 (0)113 395 6200

PARSONS BRINCKERHOFF

© WSP UK Ltd www.wsp-pb.com

Client **Working on behalf of**

highways england

Project Title **A1 BIRTLEY TO COALHOUSE**

Drawing Title **OPTION 1A - OFFLINE REPLACEMENT OF ALLERDENE RAILWAY EXISTING STATUTORY UNDERTAKERS APPARATUS SHEET 2 OF 3**

Scale	1:1250	Drawn	J.Singh	Checked	S.Ghosh	Approved	N.Rawcliffe	Authorised	---
Original Size	A1	Date	23/05/17	Date	23/05/17	Date	23/05/17	Date	---
Drawing Status	INITIAL STATUS OR WIP								S0

Drawing Number	HE551462	Project	BCH	Originator	WSP	Volume	VUT	Project Ref. No.	
Location	DR	Type	D	Role	00002	Number	P02	Revision	

DO NOT SCALE

Millimetres

0 10

100

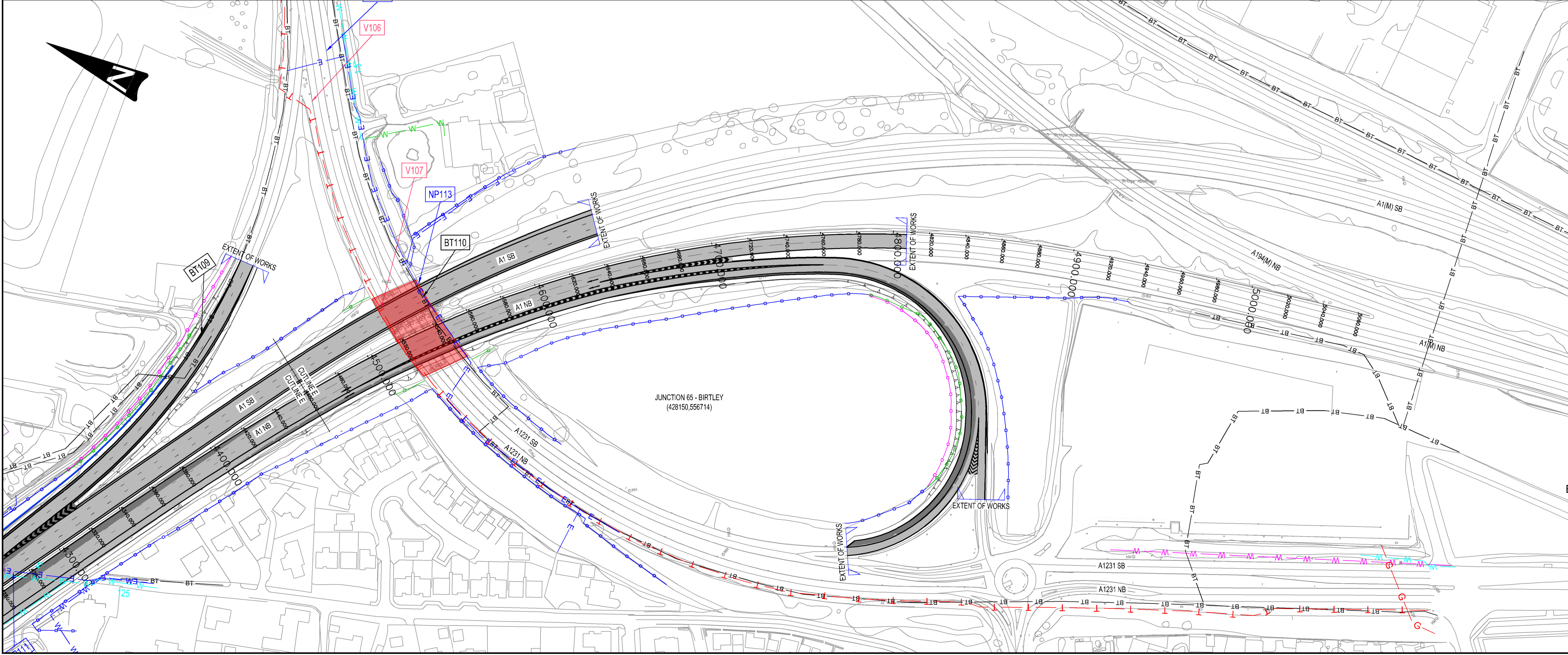
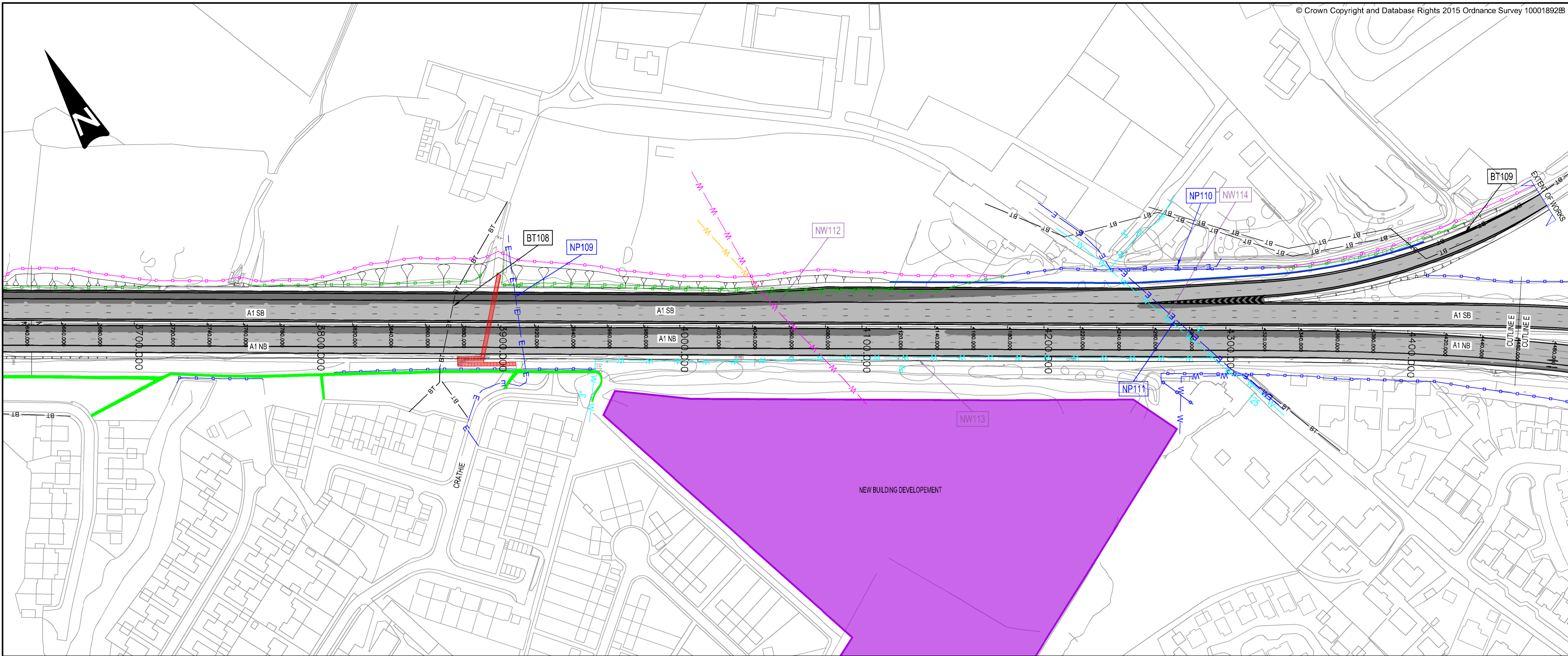

A1

KEY

	EXISTING STRUCTURE
	PROPOSED STRUCTURE
	PROPOSED RETAINING WALL
	PROPOSED HIGHWAYS FENCE LINE
	EXISTING HIGHWAYS FENCE LINE
	NEW CARRIAGEWAY CONSTRUCTION
	EXISTING CARRIAGEWAY TO BE RETAINED
	PROPOSED DRAINAGE DITCH
	PROPOSED FOOTPATH DIVERSION
	EXISTING FOOTPATH
	BT DUCT
	INSTALCOM
	NORTHUMBRIAN WATER COMBINED
	NORTHUMBRIAN WATER FOUL
	NORTHUMBRIAN WATER ABANDONED
	NORTHUMBRIAN WATER SURFACE
	NORTHUMBRIAN WATER TREATED
	NORTHUMBRIAN WATER DISTRIBUTION
	NON NORTHUMBRIAN WATER PRIVATE
	NORTHERN GAS LOW PRESSURE
	NORTHERN GAS MEDIUM PRESSURE
	NORTHERN GAS INTERMEDIATE PRESSURE
	NORTHERN GAS REGIONAL HIGH PRESSURE
	VIRGIN MEDIA CABLE
	NORTHERN POWER GRID CABLE
	VODAFONE CABLE
	UTILITY REFERENCE

- NOTES**
1. LOCATION OF SERVICE PLANT SHOWN ON THIS DRAWING HAS BEEN OBTAINED FROM C2 STATUTORY UNDERTAKERS RETURNS AND IS SHOWN INDICATIVELY. THE STATUTORY UNDERTAKERS RETURNS ARE TO SATISFY THEMSELVES OF THE LOCATION AND EXTENTS OF SERVICE PLANT.
 2. REFER TO SECTION 3.10 OF THE TECHNICAL APPRAISAL REPORT FOR DETAILS OF THE DIVERSION WORKS PROPOSED.
 3. ALL DIAMETERS OF WATER MAINS ARE MEASURED IN MILLIMETERS UNLESS OTHERWISE STATED.

IMPORTANT WARNING

THE INFORMATION CONCERNING THE LOCATION AND/OR DEPTH OF THE PUBLIC UTILITY APPARATUS IS PROVIDED ON THIS DRAWING AS AN INDICATIVE GUIDE ONLY. NO GUARANTEE AS TO THEIR CORRECTNESS IS GIVEN OR IMPLIED.

THESE DRAWINGS SHOULD NOT BE RELIED UPON IN THE EVENT OF EXCAVATIONS OR OTHER WORKS MADE NEAR TO THE APPARATUS, WHICH MAY EXIST AT VARIOUS DEPTHS AND MAY DEVIATE FROM THE MARKED ROUTE. IT SHOULD ALSO BE NOTED THAT A SINGLE LINE SHOWN ON THE PLAN MAY INDICATE THE PRESENCE OF MORE THAN ONE CABLE.

THE CONTRACTOR IS REQUIRED TO ENSURE THAT THE LOCATIONS OF BELOW GROUND SERVICES ARE ESTABLISHED/CONFIRMED ON SITE PRIOR TO ANY EXCAVATIONS OR OTHER WORKS WHICH MAY AFFECT THE EXISTING SERVICES.

PRIOR TO ANY WORKS ON SITE, THE CONTRACTOR SHALL REFER TO:
 HSG47 - AVOIDING DANGER FROM UNDERGROUND SERVICES (BY HSE)
 HGS185 - HEALTH & SAFETY IN EXCAVATIONS (BY HSE)
 CONSTRUCTION INFORMATION SHEET (CIS) 8 - SAFETY IN EXCAVATIONS (BY HSE)
 GENERAL SERIES (GS) 6 - AVOIDANCE OF DANGER FROM OVERHEAD ELECTRIC LINES (BY HSE)

22/05/17					
P01	22/05/17	JSM/T		J.S	SG NGR
P02	23/05/17	Design update, NDR 111 added		J.S	SG NGR
Rev.	Date	Description	By	Chkd	Appd

WSP Three White Rose Office Park, Millshaw Park Lane, Leeds, LS11 0DL
 Tel: +44 (0)113 395 6200

PARSONS BRINCKERHOFF

© WSP UK Ltd www.wsp-pb.com

Client **Working on behalf of**

highways england

Project Title **A1 BIRTLEY TO COALHOUSE**

Drawing Title **OPTION 1A - OFFLINE REPLACEMENT OF ALLERDENE RAILWAY BRIDGE EXISTING STATUTORY UNDERTAKERS APPARATUS SHEET 3 OF 3**

Scale	1:1250	Drawn	J.Singh	Checked	S.Ghosh	Approved	N.Rawcliffe	Authorised	---
Original Size	A1	Date	23/05/17	Date	23/05/17	Date	23/05/17	Date	---
Drawing Status	INITIAL STATUS OR WIP								S0

Drawing Number	HE551462	Originator	WSP	Volume	VUT	Project Ref. No.	
BCH	DR	D	00003			Revision	P02
Location		Type	Role	Number			

Appendix F

NWR OUTLINE REQUIREMENTS – THIRD PARTY WORKS

Appendix F-1

**NWR OUTLINE REQUIREMENTS – THIRD PARTY
WORKS**



GENERAL ENGINEERING REQUIREMENTS IN RESPECT OF CONSTRUCTING NEW BRIDGES OVER THE OPERATIONAL RAILWAY

**ISSUED IN CONNECTION WITH:
PP9655 A1 GATESHEAD WESTERN BYPASS – ALLERDENE RAILWAY
BRIDGE RENEWAL**

1. GENERAL CONSIDERATIONS IN RESPECT OF THE SAFETY OF THE RAILWAY

Network Rail has a statutory obligation to provide safe train paths for use by Train Operating Companies and as such must take all reasonable steps to ensure that the safety of the railway is not compromised through the activities of others on sites neighbouring the railway or, where permitted by Network Rail, on Network Rail property.

This document provides guidance on the design and construction of new overbridges and should be read in context with the general provisions of the Network Rail document entitled "Requirements for Constructional Work On or Near Railway Operational Land by Outside Parties".

2. Land Issues

The right to create and maintain a new facility for crossing over the railway will generally require to be negotiated with Network Rail's Commercial Property function and will be regulated under a formal agreement. Network Rail will not generally accede to the sale of operational land and will, as a matter of course, object to any attempt to obtain operational land by compulsory purchase.

3. Bridge Agreement

The ownership, future maintenance and general management responsibilities of any new overbridge crossing the operational railway will require to be regulated under a formal Bridge Agreement to be negotiated with Network Rail's Asset Protection function.

Network Rail will not generally accede to accepting any additional liability whatsoever associated with new overbridges.

Any new overbridge will require to be taken into the stewardship of a recognised bridge authority and in the event that none other can be found, for example in the case of a private access bridge for an individual or Company, Network Rail may adopt the role of bridge authority on behalf, and wholly at the cost, of the Outside Party.

In circumstances where a new overbridge requires to be constructed in advance of its being adopted, for example retrospectively by a local Roads Authority in connection with a private development, then a tripartite agreement among Network Rail, the Roads Authority and the Outside Party may require to be entered into, in

which circumstances Network Rail will generally require to enter into a separate bond with the Outside Party to address any interim commercial risks to Network Rail.

4. Design Approval

Network Rail requires technical acceptance of the bridge design in accordance with Company Standard NR/L2/CIV/003 “Engineering Assurance of Building and Civil Engineering Works”. The process requires submission of:

- Form F001, Approval in Principle
- Form F002, Statement of Design Intent
- Form F003, Certificate of Design and Check
with appropriate supporting documentation.

Where a new overbridge will be built or adopted by a bridge authority other than Network Rail, NR/L2/CIV/003 permits that authority’s equivalent design approval processes to be substituted, where these exist. Where an equivalent alternative design approval process is followed, however, Network Rail will require the opportunity to comment upon the Technical Approval in Principle or equivalent submission. In addition Network Rail will require (a) a Category III independent design check to be carried out and (b) to be provided with copies of appropriately signed Design and Design Check Certificates.

In the unusual event that Network Rail is to adopt a new overbridge, the design approval process will necessarily follow that defined in NR/L2/CIV/003.

5. Design Specifications

5.1. Clearances:

5.1.1. General: The following advice on vertical and lateral clearances is offered on the basis of ensuring that the design solution will provide sufficient clearance to afford safe operation of the existing railway and any future development of it, including electrification. It also takes cognisance of some of the issues associated with the construction and maintenance of a new structure.

The recommendations on vertical and lateral clearances assume straight and level track and additional allowances should, therefore, be made where the track geometry is other than straight and level.

In exceptional circumstances the general advice on vertical and lateral clearances may be further refined on the basis of railway industry operating criteria obtainable through further consultation with Network Rail’s Engineer.

5.1.2. Signal Sighting: The advice on clearances provided in clause 5.1.5 below is valid only in the situation where there will be no effect on a train driver’s ability to sight signals. Where signal sighting becomes a critical issue in determining vertical or horizontal clearance for a new overbridge, specific advice shall be provided by Network Rail.

5.1.3. Existing Electrification: Where a bridge is to be constructed over an already electrified rail route, Network Rail's preference is for a design which negates the need to alter the existing overhead line equipment (OHLE). Only in circumstances where other design constraints prevent this from being achievable will Network Rail consider alterations to existing apparatus. Any exposed metalwork on new structures over electrified routes may require to be electrically connected to Network Rail's earthing system by bonding. More than one bond may be required if electrical continuity between bridge components cannot be guaranteed.

5.1.4. Future Electrification: Where the height and / or length of a proposed new structure is likely to inhibit the future installation of free standing OHLE, Network Rail may request that provision be made in the design of the new structure to allow the fixing to it of OHLE support apparatus.

5.1.5. Minimum Dimensions

5.1.5.a. Vertical Clearances

The minimum headroom required is the greater of 5.2m above existing highest rail level or 1.0m above existing OHLE.

5.1.5.b. Horizontal Clearances

Network Rail would generally prefer that abutments and foundations are not sited within Network Rail's property boundary but, where this is not practicable or dispensation is granted, the design must allow piers / abutment to be constructed behind temporary fences erected at least 3.0m from the nearest rail. Supports with a lateral clearance less than 4.5m must be designed to withstand derailment loading.

6. Parapets

6.1. General

Parapets must be designed to Department of Transport Design Manual for Roads and Bridges TD 19/06, BS EN 1317, BS6779, BS 7818 and BS EN 50122-1:2011 +A1:2011 as appropriate.

Parapets should be imperforate and be constructed to provide no toe holds on the road faces. Parapets with a width greater than 100mm at the top should be profiled to deter walking or climbing. Anti-climb measures should be incorporated on the external faces of parapets to prevent access within 3.0m measured horizontally from the outermost rail of any track or live component of OHLE.

6.2. Containment

Network Rail is obliged to operate an open access policy for the benefit of train and freight operating companies. Other than in exceptional circumstances, H4a Very High Containment parapets will be required for all new vehicular bridges over the railway.

6.3. Height

The minimum parapet height required over, and for at least 3.0m beyond the outer rails or live OHLE, is 1.5m (1.8m for bridleways and, preferably, cycleways).

Higher parapets, or total enclosure of footbridges, may be required to comply with BS EN 50122-1:2011 +A1:2011 or in areas with known vandalism problems.

7. Form of Construction

Network Rail expects new overbridges to be constructed without disruption to scheduled train services. This will generally mean that elements of the works will require to be carried out during 'no scheduled trains' periods (i.e. within Rules of the Route possessions and, for electrified routes, under isolation of the OHLE). Consequently these elements may be restricted to being carried out during a few hours per night and possibly only at week ends. Possessions/isolations are generally only available subject to a minimum 18 weeks advance notice period and provided that the proposed works do not conflict with Network Rail planned works.

The potential consequences of these constraints should be considered as fundamental in selecting an appropriate form of construction early in the design process.

8. Procurement of Design and Construction

The Outside Party will be responsible for procuring design and construction services associated with the construction of new overbridges. Consultants and Contractors employed for these elements do not have to be registered to carry out work for Network Rail, but Network Rail must be consulted regarding proposed companies before any invitations to tender are issued and reserves the right of veto.

Appendix G

**OUTLINE GENERAL ARRANGEMENT DRAWINGS – STRUCTURE
OPTIONS**

Appendix G-1

ST001 NETWORK ARCH GA

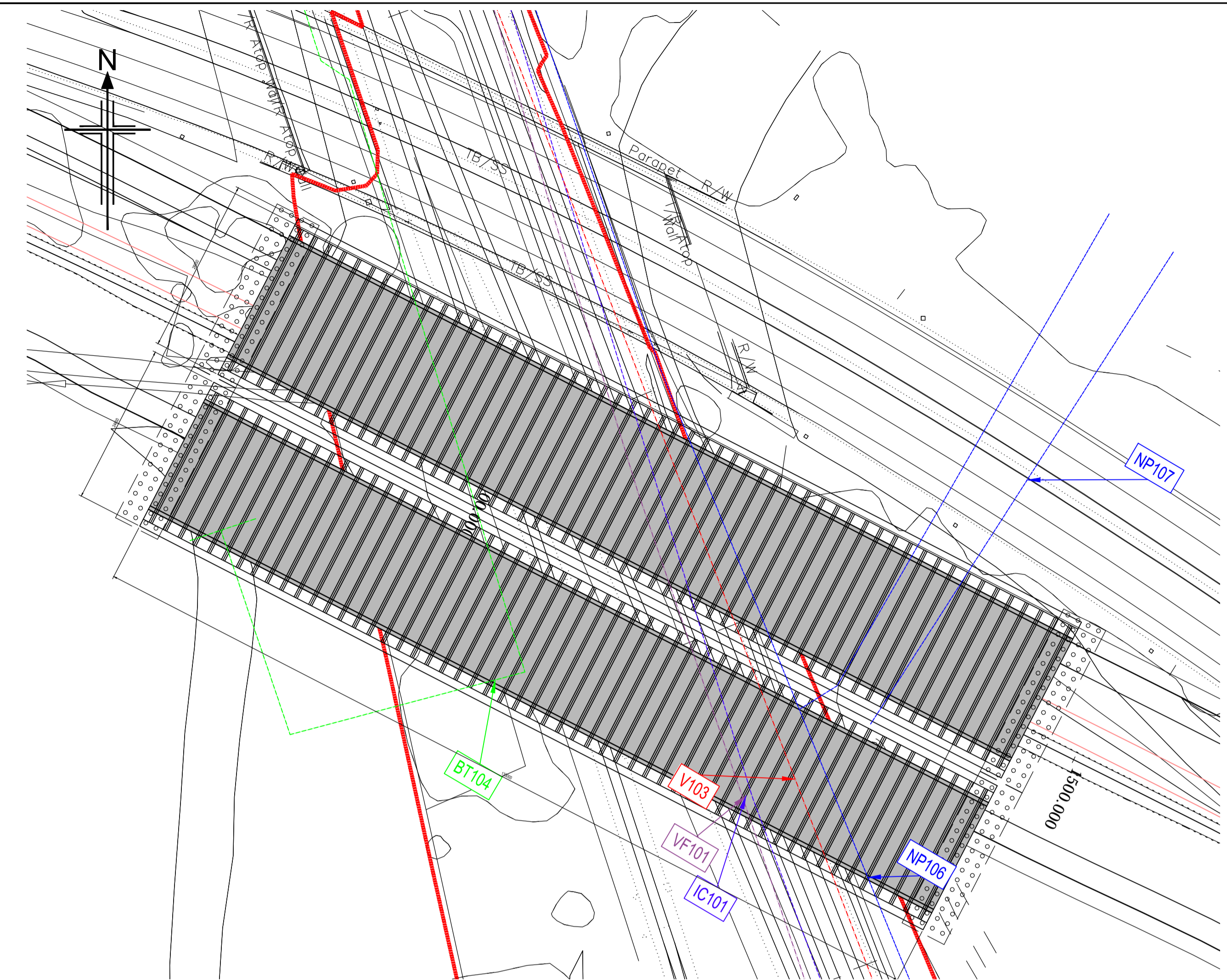

PLAN
SCALE 1:1000

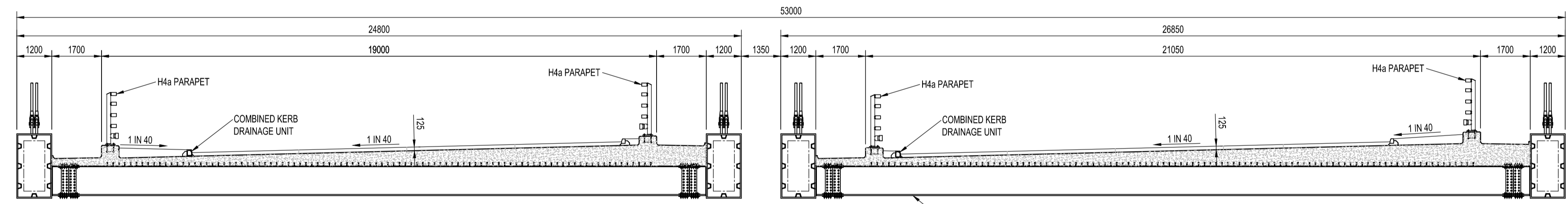

SECTION A-A
SCALE 1:100

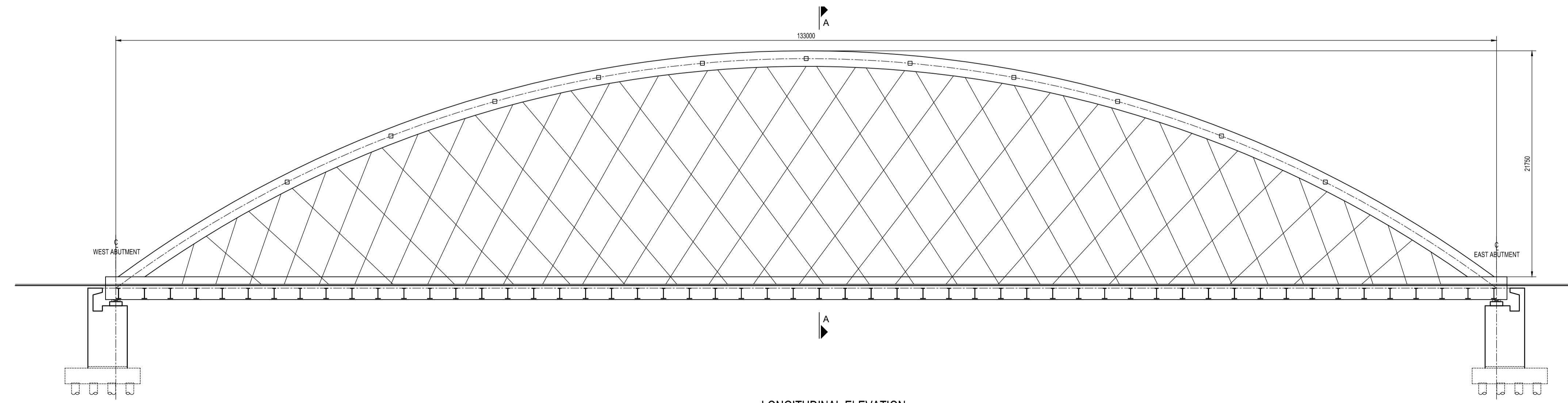

LONGITUDINAL ELEVATION
SCALE 1:200

- NOTES**
- REFER TO SHEET 1 OF 2 FOR GENERAL NOTES.
 - STRUCTURAL STEELWORK TO BE BONDED AND EARTHED IN ACCORDANCE WITH NRS/PEL/21085 AND BS EN 50122-1.
 - THE STRUCTURAL STEELWORK SHALL BE ADEQUATELY BONDED AND EARTHED DURING CONSTRUCTION AND ON COMPLETION. THE STEELWORK IS BOLTED TOGETHER USING BRACING WHICH ON COMPLETION WILL PROVIDED ELECTRICAL CONTINUITY THROUGHOUT THE STRUCTURE FOR PASSAGE OF 25KV FAULT CURRENTS OF SHORT DURATION.
- CONSTRUCTION SEQUENCE:**
- BELOW IS AN INDICATIVE CONSTRUCTION SEQUENCE OF KEY OPERATIONS FOR THE PROPOSED CONSTRUCTIONS OF THE BRIDGE. DETAILS ARE ALSO PROVIDED OF ANTICIPATED POSSESSION AND NON-POSSESSION WORKS.
- ESTABLISH SAFE WORKING AREA BY ERECTING A TEMPORARY FENCE ALONGSIDE THE RAILWAY TO PREVENT ACCESS TO AREAS CLASSED AS 'ON OR NEAR THE LINE'; (ERECTED IN ACCORDANCE WITH NETWORK RAIL STANDARDS AND WILL BE SUBJECT TO TEMPORARY WORKS APPROVAL). THIS IS REQUIRED TO PREVENT THE NEED FOR POSSESSIONS DURING FOUNDATION AND SUBSTRUCTURE WORKS.
 - ESTABLISH PILING PLATFORM. INSTALL PILES - OUTSIDE POSSESSION WORKING.
 - CAST THE REINFORCED CONCRETE PILE CAP - OUTSIDE POSSESSION WORKING.
 - CAST THE REINFORCED CONCRETE ABUTMENT WALLS - OUTSIDE POSSESSION WORKING.
 - INSTALL BEARINGS - OUTSIDE POSSESSION WORKING.
 - BACKFILL BEHIND ABUTMENT UP TO BEARING SHELF LEVEL - OUTSIDE POSSESSION.
 - BEHIND THE ABUTMENTS ON THE WEST BUILD THE NORTH ARCH STEEL WORK AWAY FROM THE TRAFFIC AND OFF THE NETWORK RAIL LAND.
 - LAUNCH THE ARCH DURING POSSESSION AND SLIDE INTO POSITION.
 - SIMILARLY CONSTRUCT THE SOUTH ARCH BEHIND THE ABUTMENTS AND LAUNCH INTO POSITION.
 - CONCRETING OF THE DECK OVER THE RAILWAY SHOULD BE DONE DURING POSSESSIONS.
 - INSTALL WATERPROOFING, KERBS, SURFACING, ETC. - OUTSIDE POSSESSION WORKING.
- KEY**
- BT DUCT
 - INSTALCOM
 - NORTHUMBRIAN WATER COMBINED
 - NORTHUMBRIAN WATER FOUL
 - NORTHUMBRIAN WATER ABANDONED
 - NORTHUMBRIAN WATER SURFACE
 - NORTHUMBRIAN WATER TREATED
 - NORTHUMBRIAN WATER DISTRIBUTION
 - NON NORTHUMBRIAN WATER PRIVATE
 - NORTHERN GAS LOW PRESSURE
 - NORTHERN GAS MEDIUM PRESSURE
 - NORTHERN GAS INTERMEDIATE PRESSURE
 - NORTHERN GAS REGIONAL HIGH PRESSURE
 - VIRGIN MEDIA CABLE
 - NORTHHERN POWER GRID CABLE
 - VODAFONE CABLE

SAFETY, HEALTH AND ENVIRONMENTAL SYMBOL LEGEND

INDICATES A RESIDUAL RISK AS A WARNING

Sl	Rev	Date	Description	Des	Chk	App

Designer: **WSP | PARSONS BRINCKERHOFF**

Three White Rose Office Park, Millshaw Park Lane, Leeds, LS11 0DL
Tel: +44 (0)113 395 6200, Fax: +44 (0)113 395 6201
http://www.wspgroup.com

Client: **highways england**

Project Title: A1 BIRTLEY TO COAL HOUSE

Drawing Title: ALLERDENE OPTION 1 - SINGLE SPAN (LONG) GENERAL ARRANGEMENT (SHEET 1 OF 2)

Scale	Drawn	Designed	Checked	Approved
as shown	JW	RP	RM	HM
Size	Date	Date	Date	Date
A1	14/09/2016	14/09/2016	14/09/2016	14/09/2016

Status: PRELIMINARY
Drawing Number: HA551462-WSP-SBR-BCH-SK-S-1700-008
Submittal: S0
Revision: P0

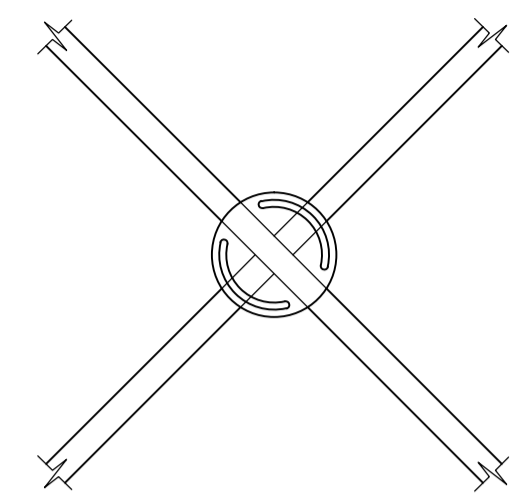

CLAMP CONNECTION DETAIL
SCALE 1:20

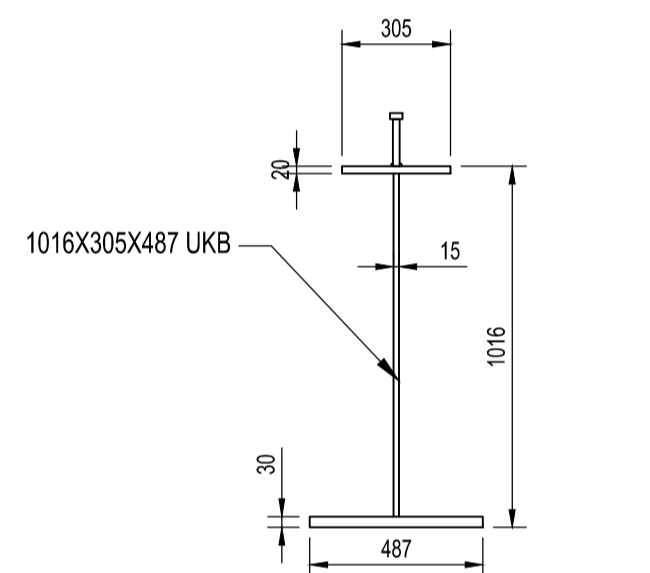

TYPICAL SECTION THROUGH CROSS BRACING
SCALE 1:20

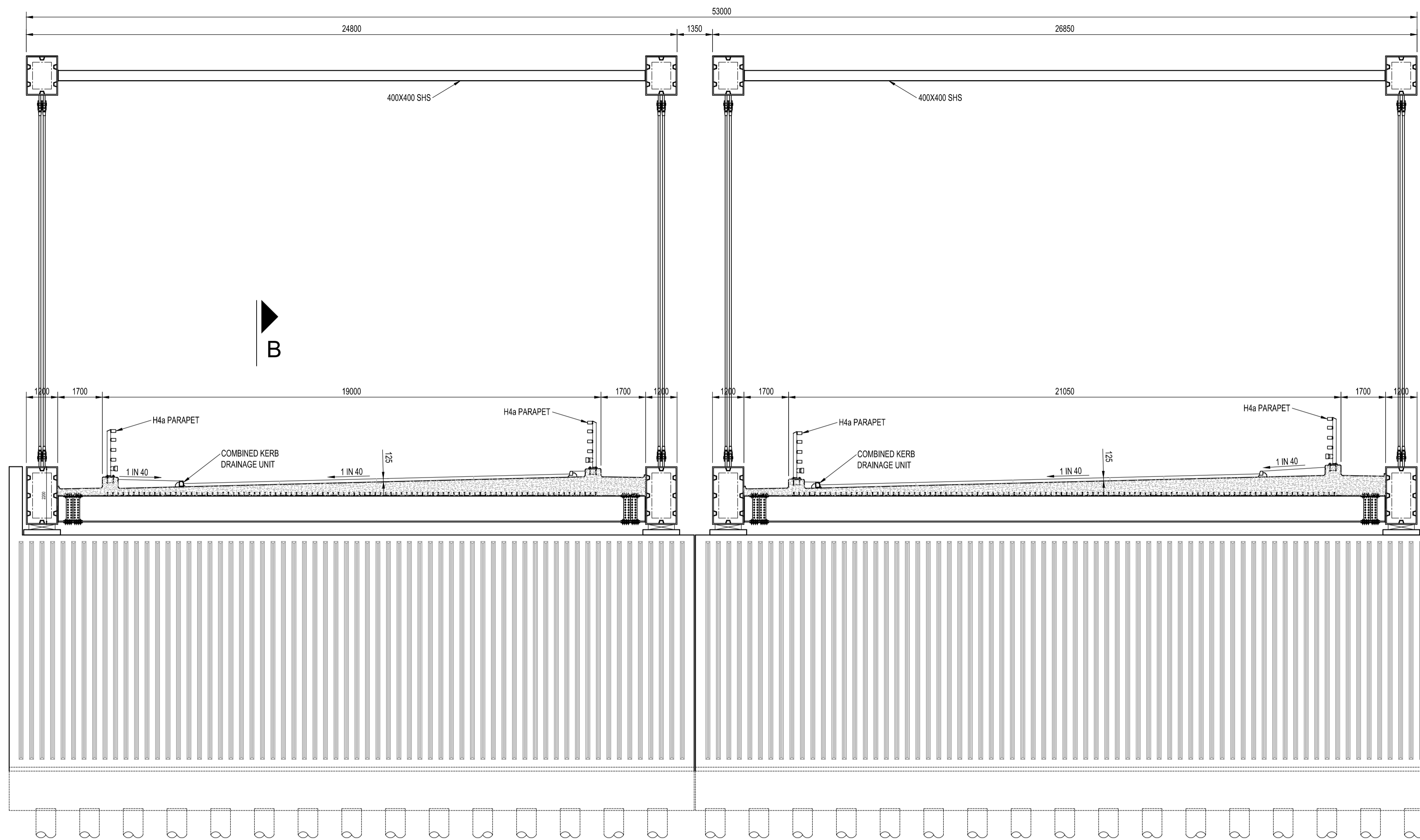

TYPICAL ABUTMENT ELEVATION
SCALE 1:100

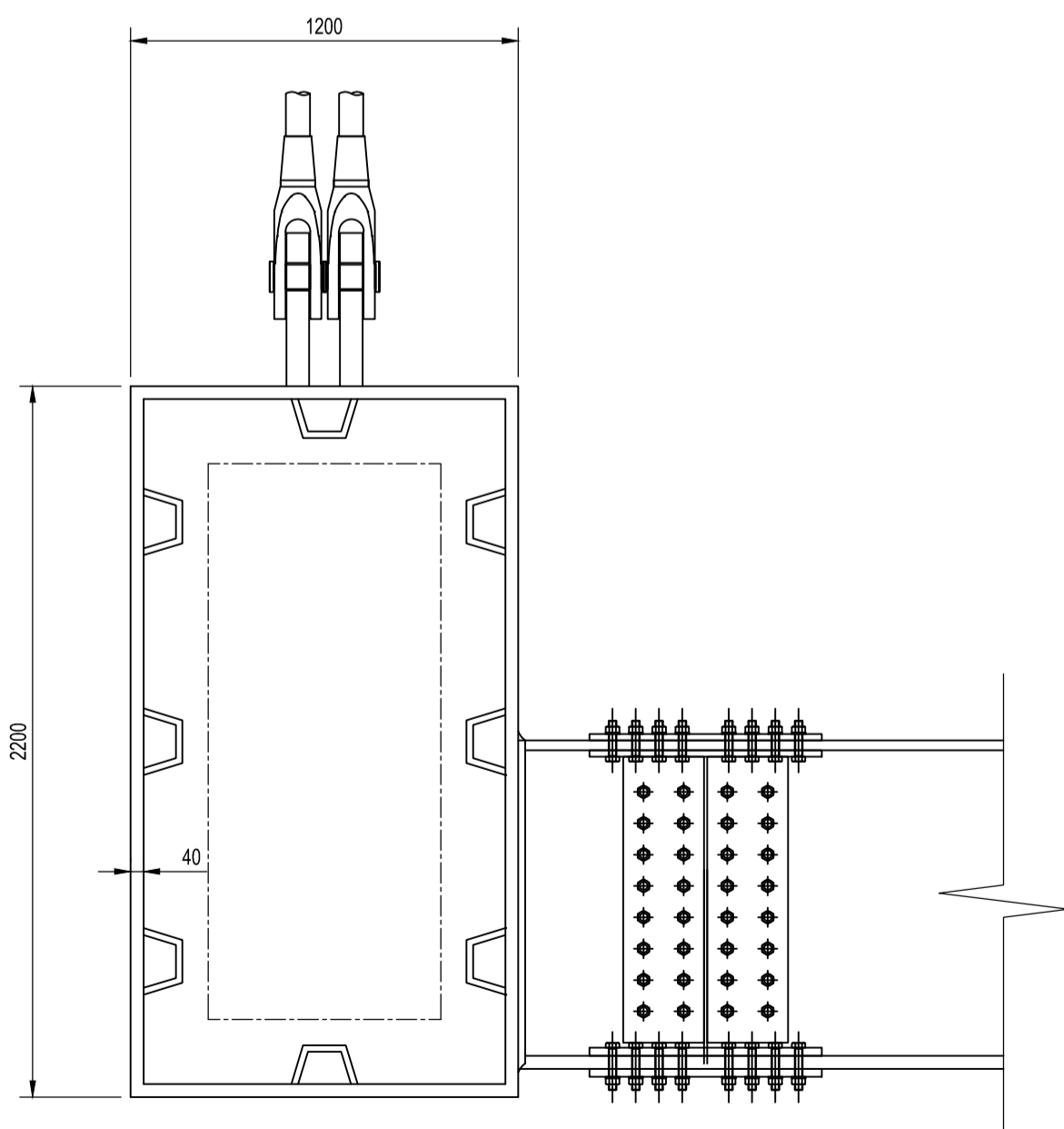

TYPICAL CROSS SECTION THROUGH MAIN GIRDER
SCALE 1:20

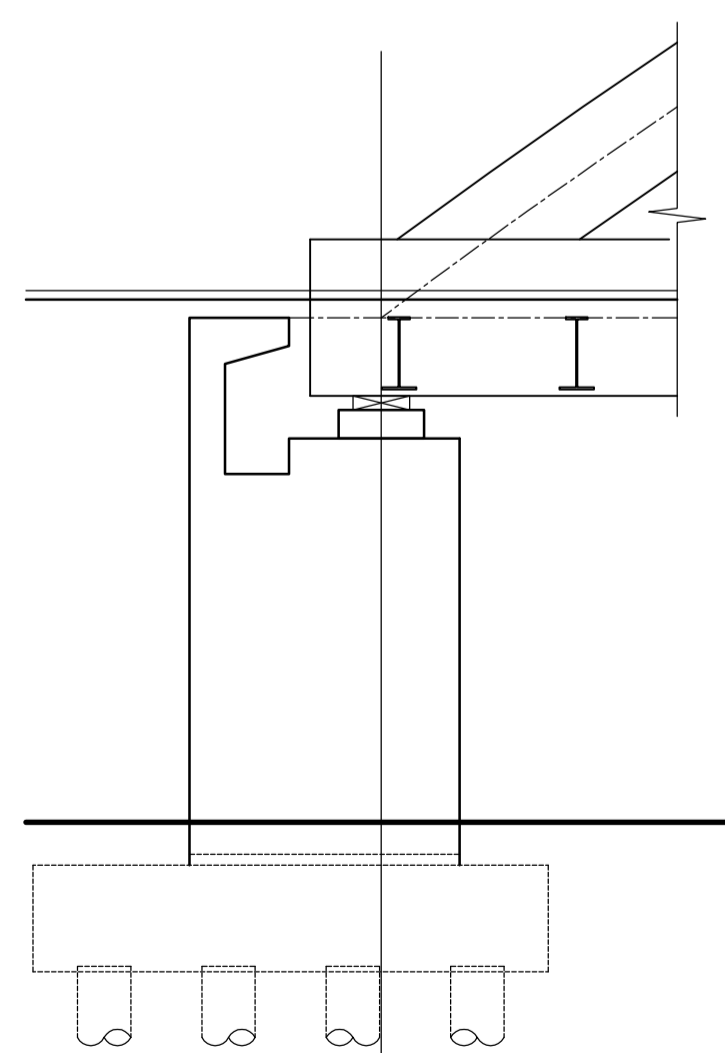

SECTION B-B
SCALE 1:100

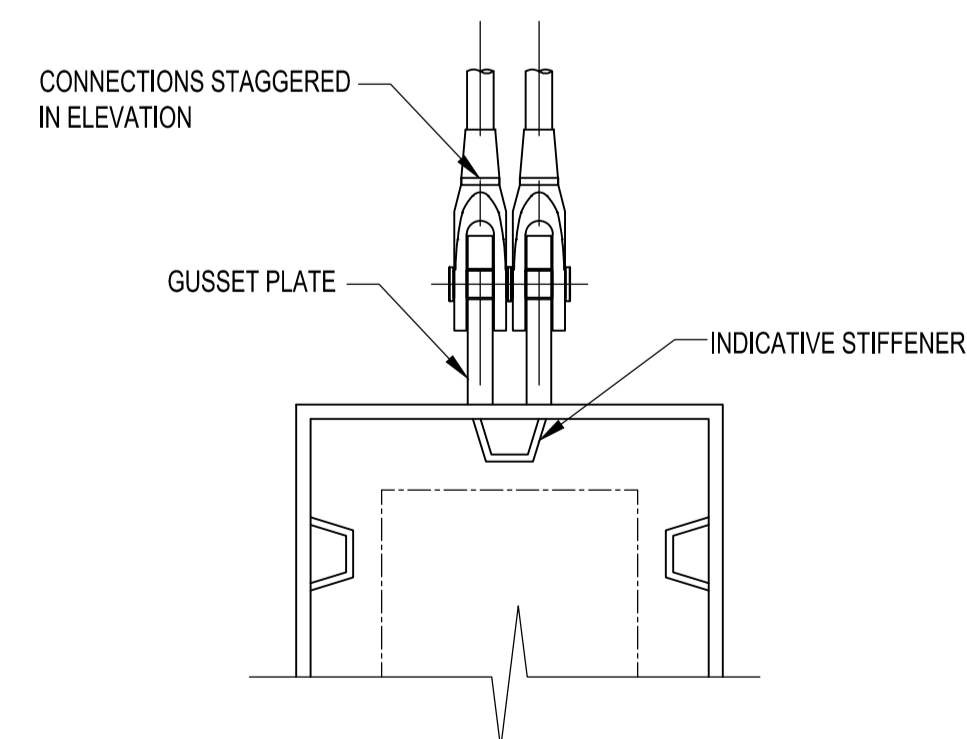

BOTTOM CHORD DETAIL
SCALE 1:20

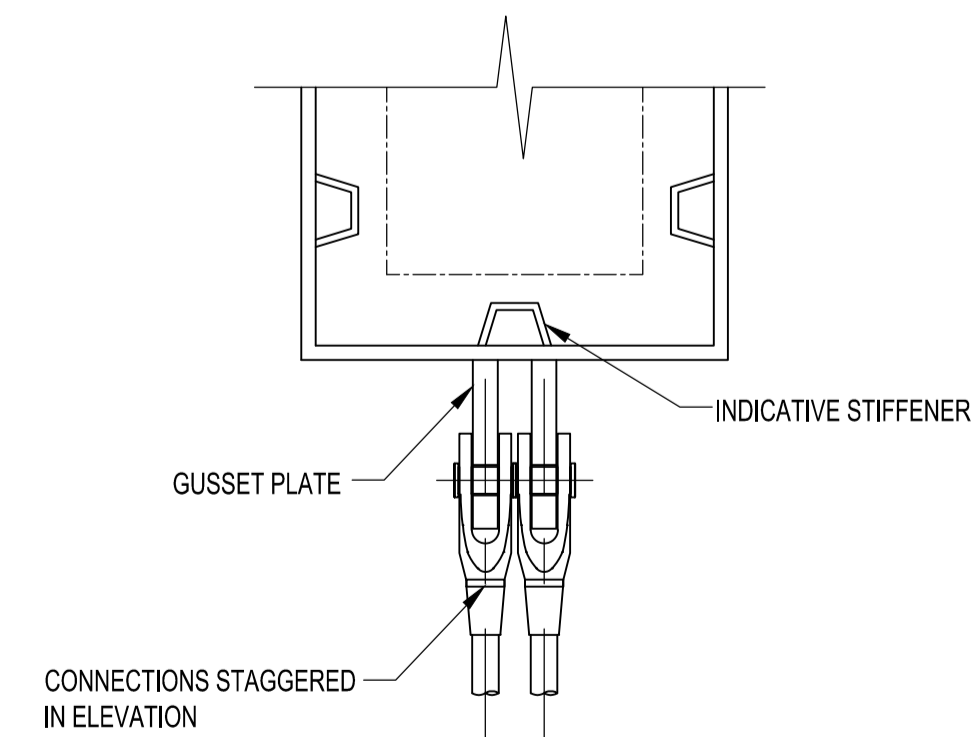

TOP CHORD DETAIL
SCALE 1:20

NOTES

1. REFER TO SHEET 1 OF 2 FOR GENERAL NOTES.

SAFETY, HEALTH AND ENVIRONMENTAL SYMBOL LEGEND

INDICATES A RESIDUAL RISK AS A WARNING

Sl	Rev	Date	Description	Des	Ok	App

Designer



Three White Rose Office Park, Millshaw Park Lane, Leeds, LS11 0DL
Tel: +44 (0)113 395 6200, Fax: +44 (0)113 395 6201
http://www.wspgroup.com

Client



Project Title

A1 BIRTLEY TO COAL HOUSE

Drawing Title

ALLERDENE OPTION 1 - SINGLE SPAN (LONG)
GENERAL ARRANGEMENT
(SHEET 2 OF 2)

Scale	Drawn	Designed	Checked	Approved	
AS SUPPLIED	JW	RP	RM	HM	
Size	Date	Date	Date	Date	
A1	14/09/2016	14/09/2016	14/09/2016	14/09/2016	
Status	PRELIMINARY				Suitability
Drawing Number	HA551462-WSP-SBR-BCH-SK-S-1700-009				Revision
					P0

Appendix G-2

ST002 SINGLE SPAN INTEGRAL BRIDGE GA

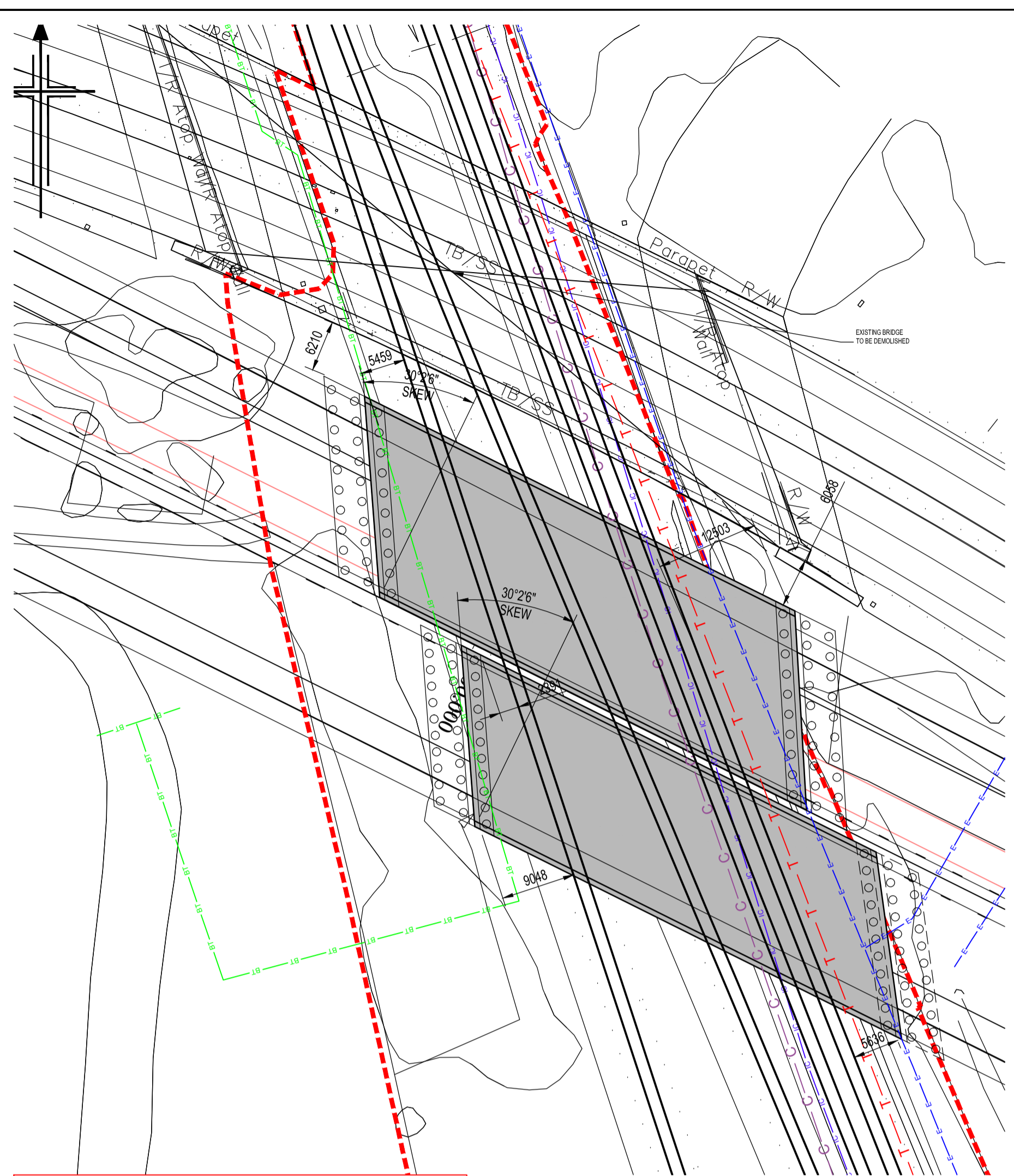

PLAN
SCALE 1:500

SERVICES AFFECTED BY EAST AND WEST PIERS TO BE DIVERTED

RETAINING WALLS OMITTED FOR CLARITY AT THIS STAGE



KEY PLAN
SCALE 1:5000

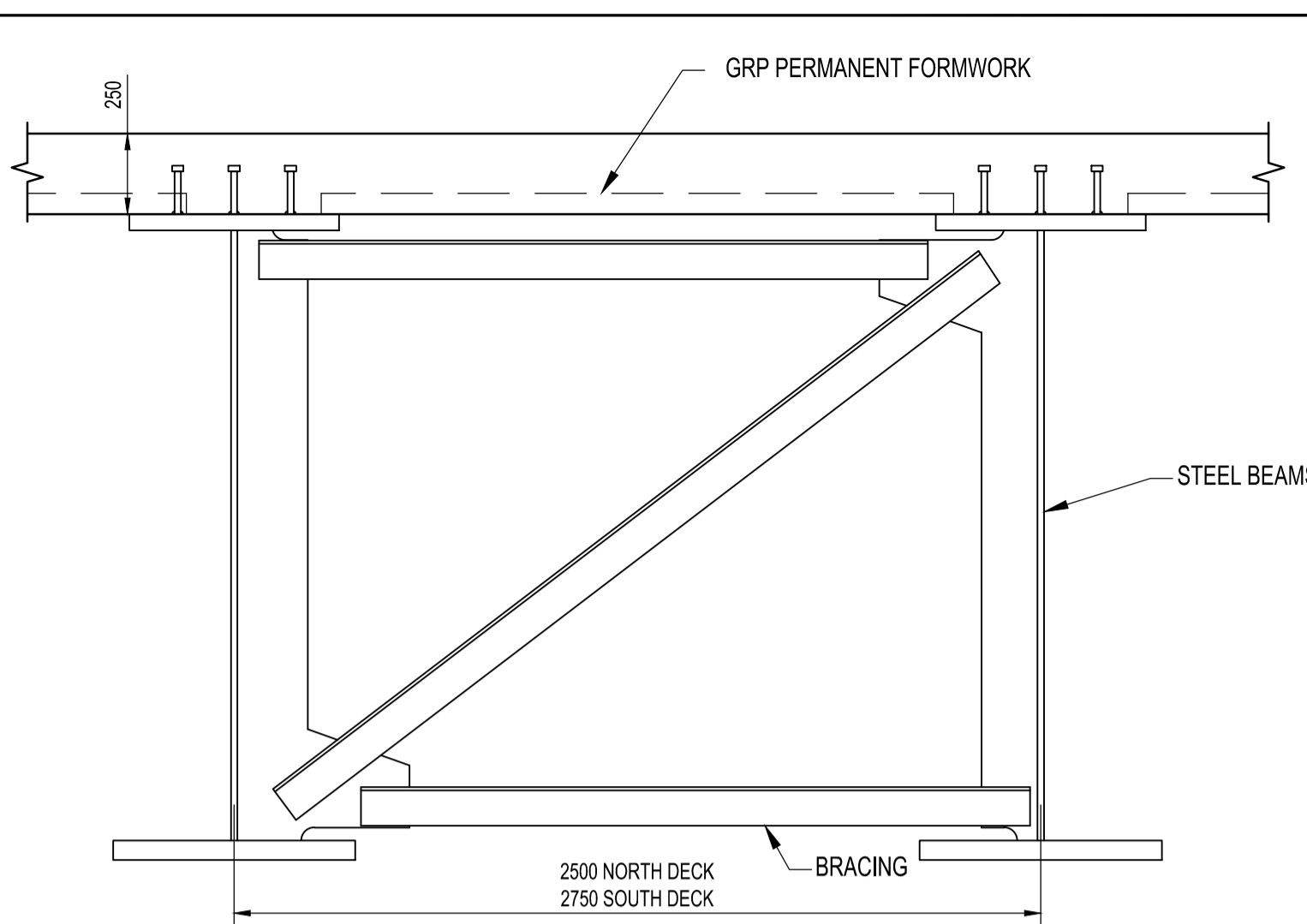

TYPICAL GRP FORMWORK DETAIL ON SOUTH DECK
SCALE 1:20

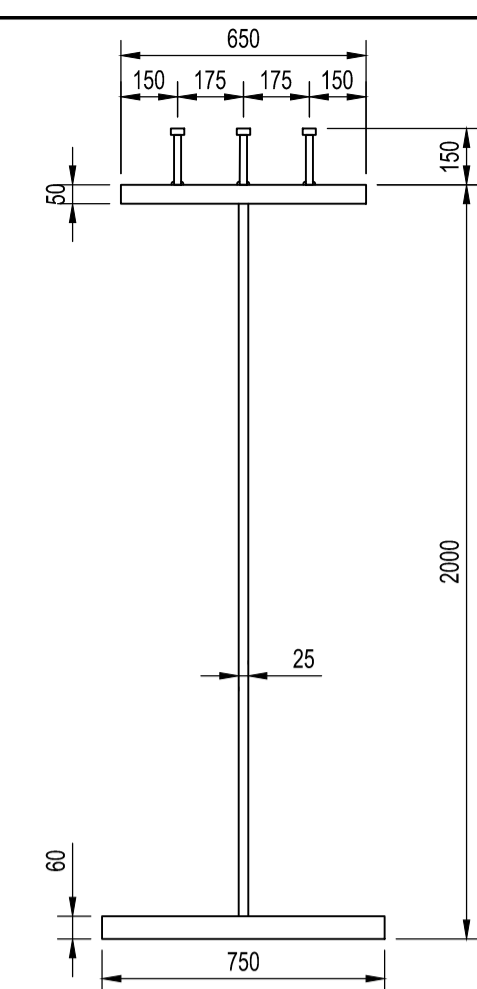

TYPICAL WEATHERING STEEL GIRDER
SCALE 1:20

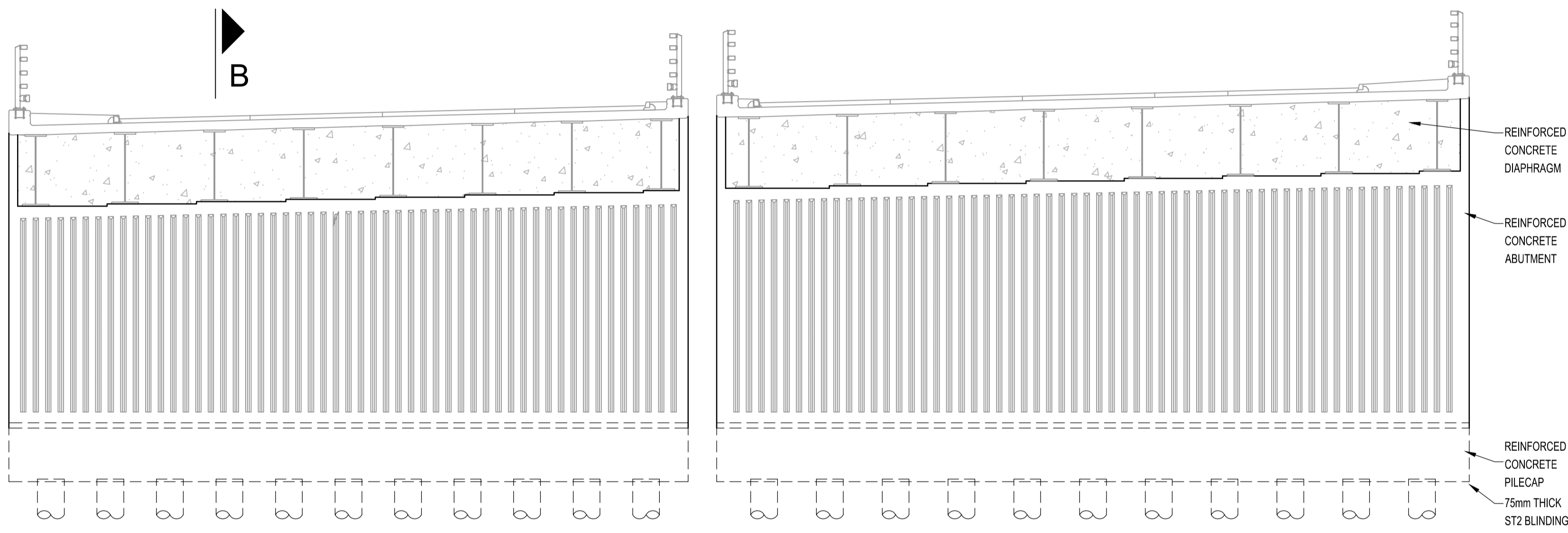

TYPICAL ABUTMENT ELEVATION
SCALE 1:100

- NOTES
1. THESE NOTES SHALL BE READ IN CONJUNCTION WITH ALL RELEVANT DRAWINGS FOR THIS STRUCTURE AND WITH RELEVANT SPECIFICATIONS. UNLESS INDICATED OTHERWISE DIMENSIONS ON THESE DRAWINGS ARE SHOWN IN MM. LEVELS ARE IN METRES ABOVE ORINANCE DATUM AND CO-ORDINATES ARE SHOWN IN METERS.
 2. ALL WORKS SHALL BE CARRIED OUT IN ACCORDANCE WITH THE SPECIFICATION OF HIGHWAY WORKS.
 3. ALL LEVELS AND DIMENSION SHALL BE CHECKED BY THE CONTRACTOR AND FABRICATOR BEFORE EXECUTING WORK. ANY DISCREPANCY SHALL BE DISCUSSED WITH THE DESIGNER BEFORE ANY CHANGES ARE MADE.
 4. FOR THE PURPOSE OF CONSTRUCTION WRITTEN DIMENSION SHALL NOT BE SCALED ONLY WRITTEN DIMENSION ARE TO BE USED. ANY DISCREPANCY SHALL BE BROUGHT TO THE ATTENTION OF THE DESIGNER.
 5. ALTERNATIVE PROPRIETARY PRODUCTS PROPOSED BY THE CONTRACTOR SHALL BE SUBJECT TO THE APPROVAL OF DESIGNER.
 6. STEELWORK SHALL BE FABRICATED AND ERECTED IN ACCORDANCE WITH BS EN1990 AND ANY OTHER ADDITIONAL REQUIREMENT STATED ON THE DRAWINGS OR APPENDIX 18/1 OF THE SPECIFICATION.
 7. ALL STRUCTURAL WEATHERING STEEL PLATES AND SECTIONS SHALL BE GRADE S355 J2W+N TO BS EN 10025-5.

CONSTRUCTION SEQUENCE:
BELOW IS AN INDICATIVE CONSTRUCTION SEQUENCE OF KEY OPERATIONS FOR THE PROPOSED CONSTRUCTIONS OF THE BRIDGE. DETAILS ARE ALSO PROVIDED OF ANTICIPATED POSSESSION AND NON-POSSESSION WORKS.

- ESTABLISH SAFE WORKING AREA BY ERECTING A TEMPORARY FENCE ALONGSIDE THE RAILWAY TO PREVENT ACCESS TO AREAS CLASSIFIED AS "ON OR NEAR THE LINE", (ERECTED IN ACCORDANCE WITH NETWORK RAIL STANDARDS AND WILL BE SUBJECT TO TEMPORARY WORKS APPROVAL). THIS IS REQUIRED TO PREVENT THE NEED FOR POSSESSIONS DURING FOUNDATION AND SUBSTRUCTURE WORKS.
- ESTABLISH PILING PLATFORM. INSTALL PILES - OUTSIDE POSSESSION WORKING.
- CAST THE REINFORCED CONCRETE PILE CAP - OUTSIDE POSSESSION WORKING.
- CAST THE REINFORCED CONCRETE ABUTMENT WALLS - OUTSIDE POSSESSION WORKING.
- BACKFILL BEHIND ABUTMENT UP TO BEARING SHELF LEVEL - OUTSIDE POSSESSION WORKING.
- DELIVER THE BEAMS ON SITE AND SPLICE AS REQUIRED.
- LIFT AND INSTALL STEEL BEAMS IN PAIRS (WITH GRP PLANKS IN PLACE) DURING RAILWAY POSSESSIONS.
- CAST DIAPHRAGM AND DECK SLAB - OUTSIDE POSSESSION WORKING.
- INSTALL FORMWORK FOR THE DECK CANTILEVER CONSTRUCTION- DURING POSSESSION WORKING.
- CAST CANTILEVER DECK AND PARAPET PLINTH - OUTSIDE POSSESSION WORKING.
- BACKFILL BEHIND ABUTMENT UP TO ROAD LEVEL OUTSIDE POSSESSION WORKING.
- INSTALL PARAPETS - DURING POSSESSION WORKING.
- INSTALL WATERPROOFING, KERBS, SURFACING, ETC. - OUTSIDE POSSESSION WORKING.

KEY

	NETWORK RAIL BOUNDARY
	BT DUCT
	INSTALCOM
	NORTHUMBRIAN WATER COMBINED
	NORTHUMBRIAN WATER FOUL
	NORTHUMBRIAN WATER ABANDONED
	NORTHUMBRIAN WATER SURFACE
	NORTHUMBRIAN WATER TREATED
	NORTHUMBRIAN WATER DISTRIBUTION
	NON NORTHUMBRIAN WATER PRIVATE
	NORTHERN GAS LOW PRESSURE
	NORTHERN GAS MEDIUM PRESSURE
	NORTHERN GAS INTERMEDIATE PRESSURE
	NORTHERN GAS REGIONAL HIGH PRESSURE
	VIRGIN MEDIA CABLE
	NORTHERN POWER GRID CABLE
	VODAFONE CABLE

SAFETY, HEALTH AND ENVIRONMENTAL SYMBOL LEGEND
INDICATES A RESIDUAL RISK AS A WARNING

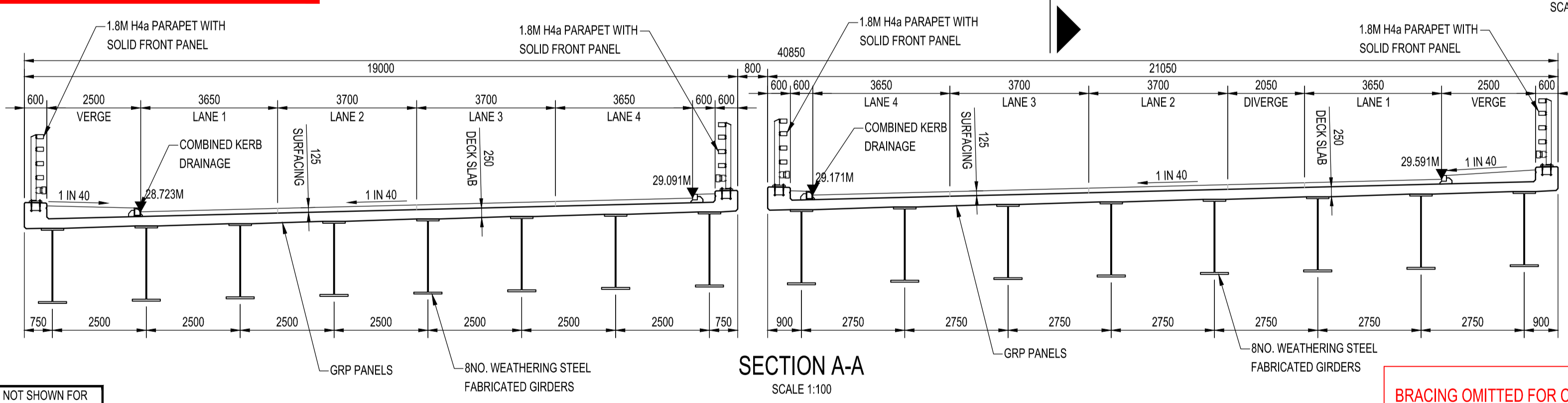

SECTION A-A
SCALE 1:100

BRACING OMITTED FOR CLARITY AT THIS STAGE

BRACING NOT SHOWN FOR CLARITY AT THIS STAGE

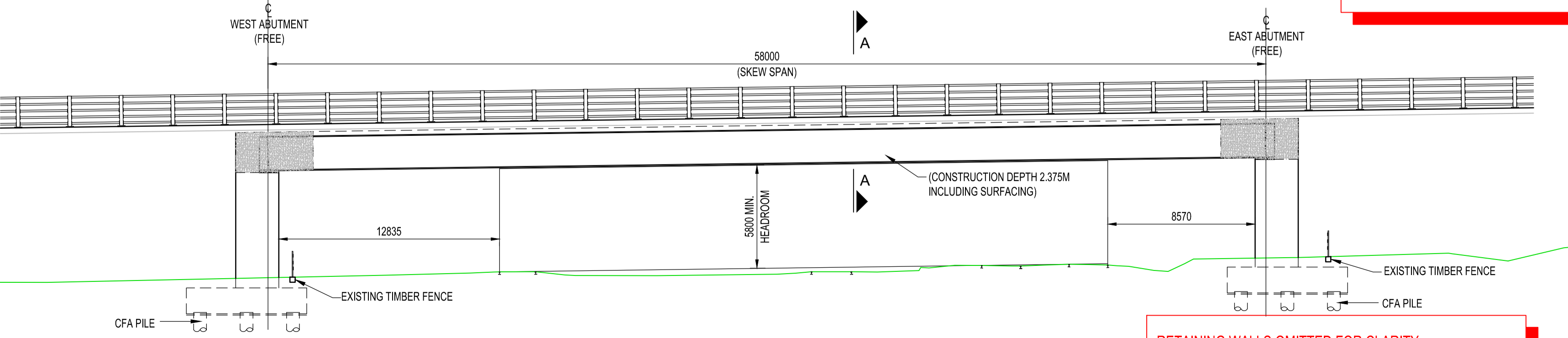

LONGITUDINAL ELEVATION
SCALE 1:200

RETAINING WALLS OMITTED FOR CLARITY AT THIS STAGE

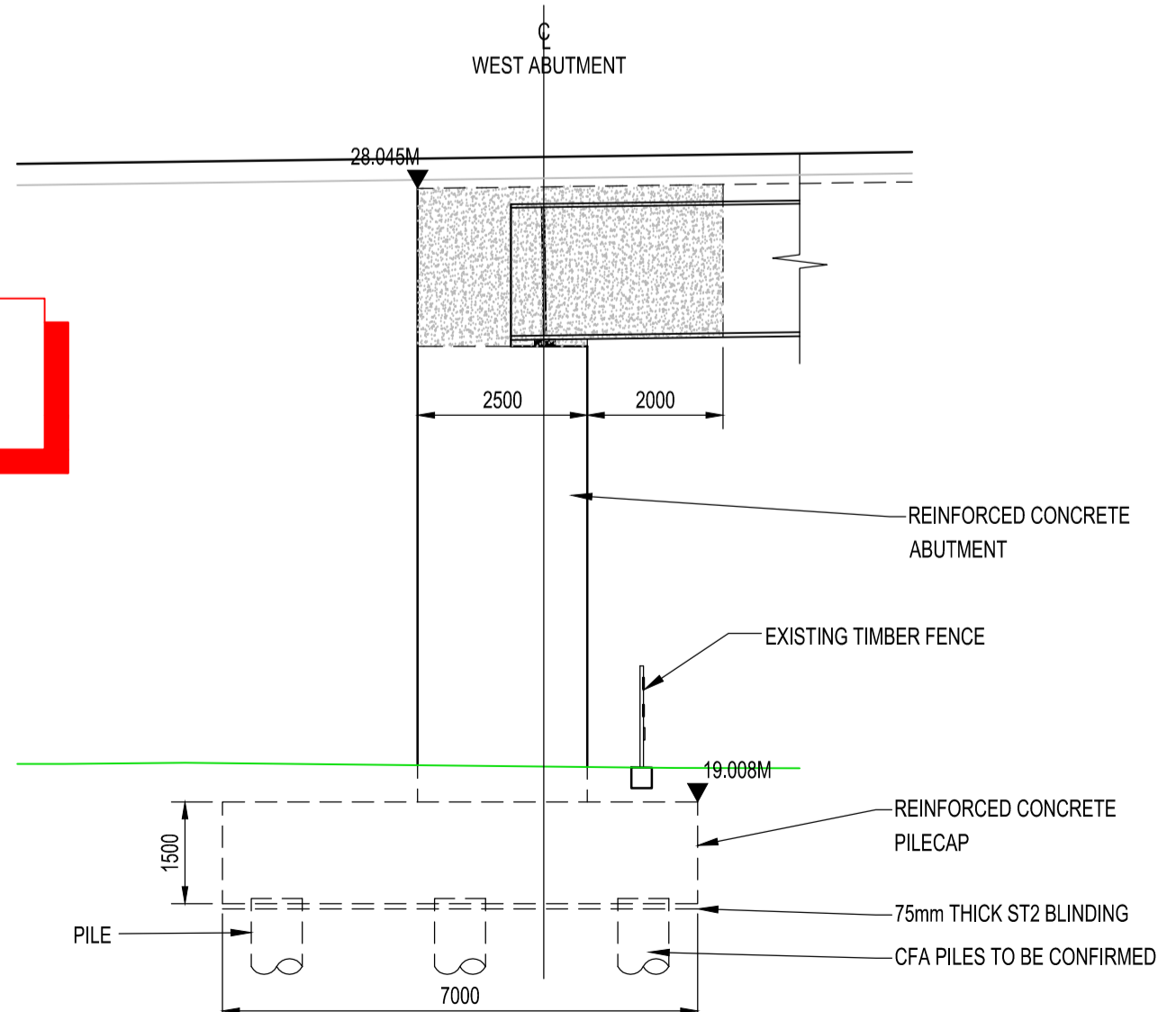

SECTION B-B
SCALE 1:100

DO NOT SCALE
A1

Designer					
Client					
Project Title	A1 BIRTLEY TO COAL HOUSE				
Drawing Title	ALLERDENE OFFLINE REPLACEMENT OPTION 2 - SINGLE SPAN INTEGRAL BRIDGE GENERAL ARRANGEMENT				
Scale	As shown at 1:1	Drawn	Designed	Checked	Approved
Size	A1	Date	Date	Date	Date
Status	PRELIMINARY				Suitability
Drawing Number	HA51462-WSP-SBR-BCH-SK-S-1700-0010				Revision
					P01

Appendix G-3

ST003 TWO SPAN CONTINUOUS BRIDGE GA

A1

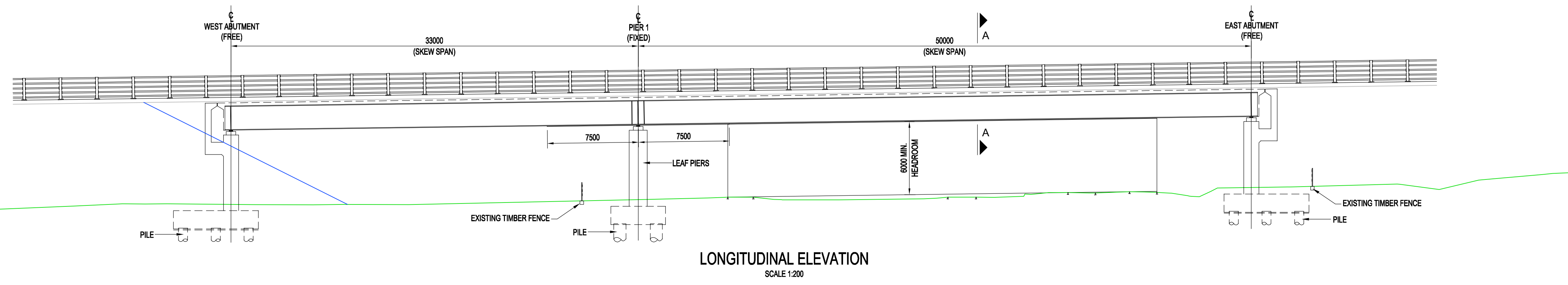
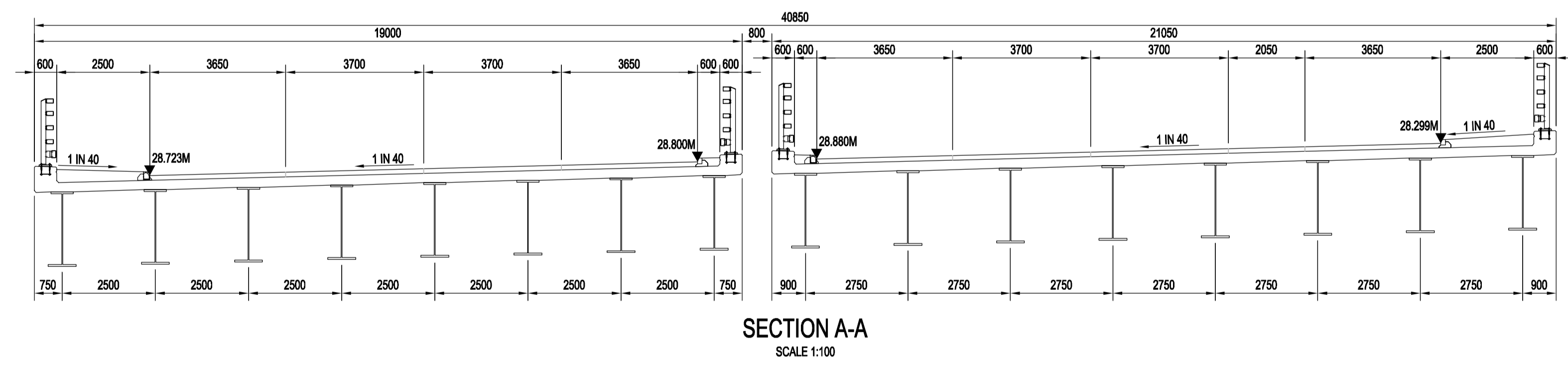
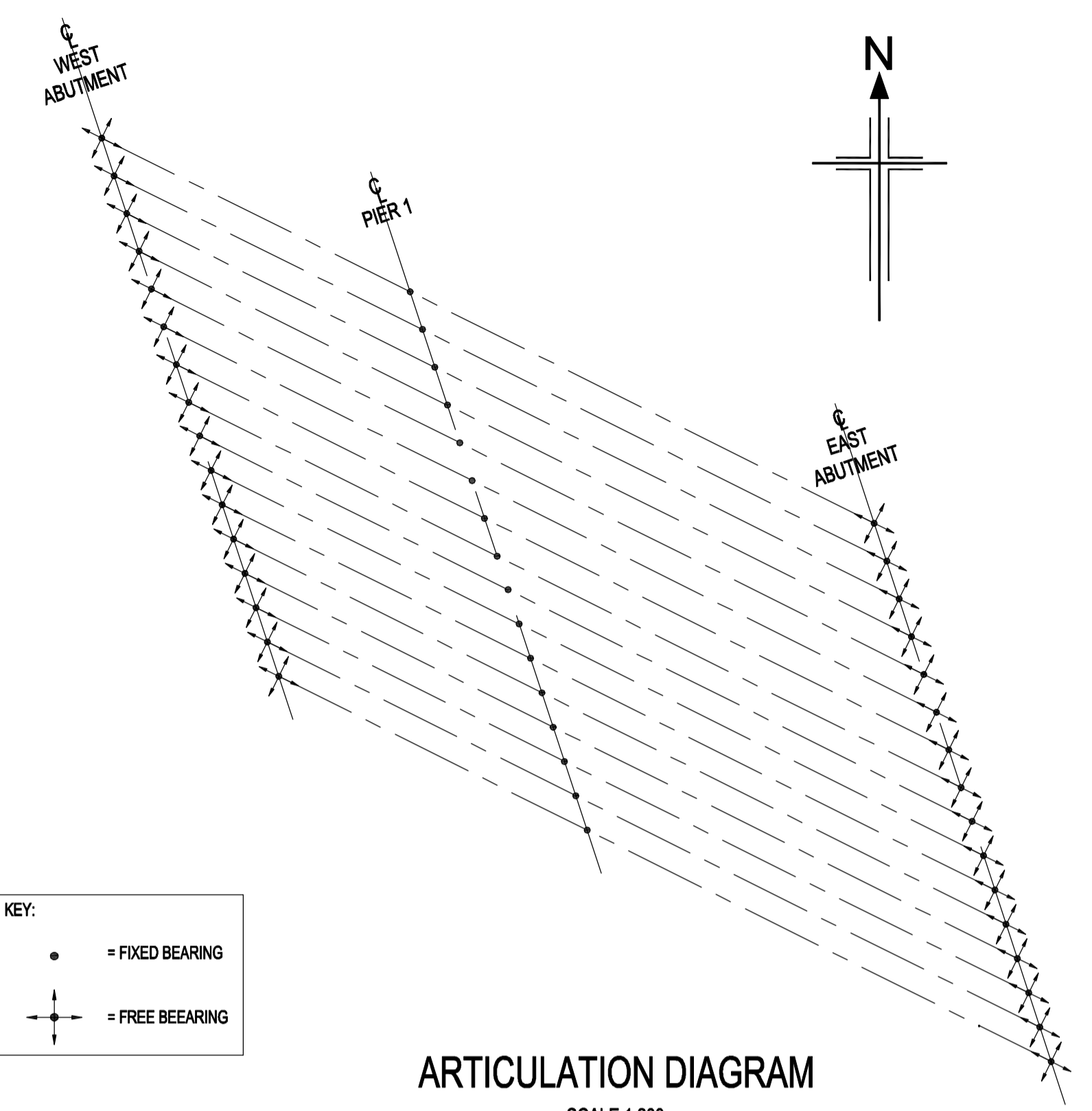
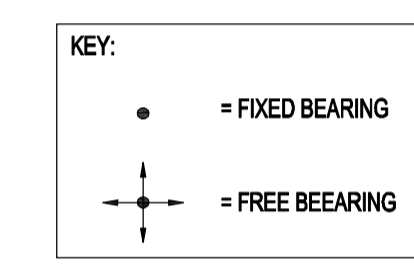
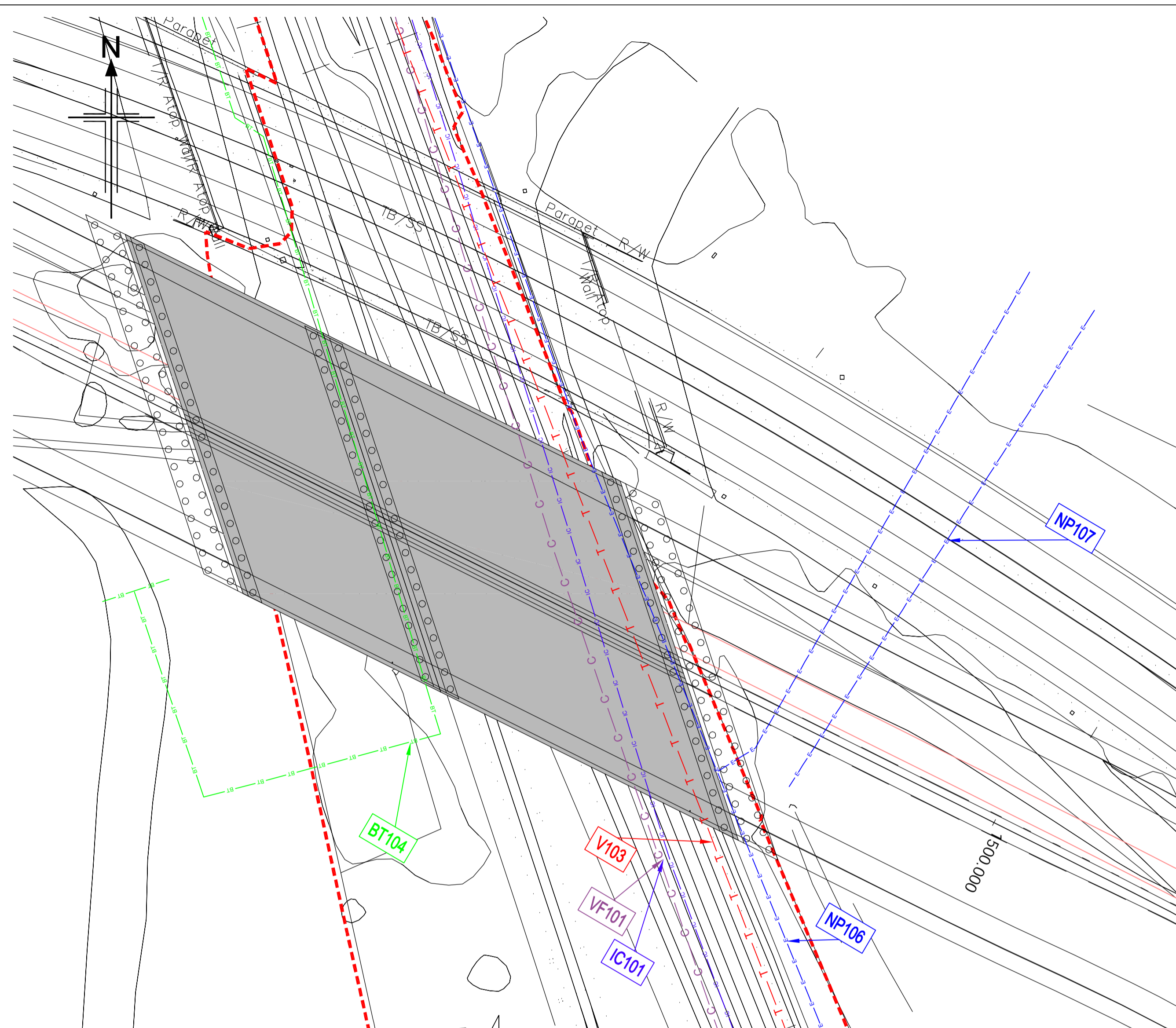

- NOTES
- REFER TO SHEET 1 OF 2 FOR GENERAL NOTES.
 - STRUCTURAL STEELWORK TO BE BONDED AND EARTHED IN ACCORDANCE WITH NR/SPIELP21085; AND BS EN 50122-1.
 - THE STRUCTURAL STEELWORK SHALL BE ADEQUATELY BONDED AND EARTHED DURING CONSTRUCTION AND ON COMPLETION. THE STEELWORK IS BOLTED TOGETHER USING BRACKET WHICH ON COMPLETION WILL PROVIDED ELECTRICAL CONTINUITY THROUGHOUT THE STRUCTURE FOR PASSAGE OF 25KV FAULT CURRENTS OF SHORT DURATION.

CONSTRUCTION SEQUENCE:
BELOW IS AN INDICATIVE CONSTRUCTION SEQUENCE OF KEY OPERATIONS FOR THE PROPOSED CONSTRUCTIONS OF THE BRIDGE, DETAILS ARE ALSO PROVIDED OF ANTICIPATED POSSESSION AND NON-POSSESSION WORKS.

- ESTABLISH SAFE WORKING AREA BY ERECTING A TEMPORARY FENCE ALONGSIDE THE RAILWAY TO PREVENT ACCESS TO AREAS CLASSED AS "ON OR NEAR THE LINE". (ERECTED IN ACCORDANCE WITH NETWORK RAIL STANDARDS AND WILL BE SUBJECT TO TEMPORARY WORKS APPROVAL). THIS IS REQUIRED TO PREVENT THE NEED FOR POSSESSIONS DURING FOUNDATION AND SUBSTRUCTURE WORKS.
- ESTABLISH PILING PLATFORM. INSTALL PILES - OUTSIDE POSSESSION WORKING.
- CAST THE REINFORCED CONCRETE PILE CAP - OUTSIDE POSSESSION WORKING.
- CAST THE REINFORCED CONCRETE ABUTMENT WALLS - OUTSIDE POSSESSION WORKING.
- INSTALL BEARINGS - OUTSIDE POSSESSION WORKING.
- BACKFILL BEHIND ABUTMENT UP TO BEARING SHELF LEVEL - OUTSIDE POSSESSION.
- DELIVER THE BEAMS ON SITE AND SPLICE AS REQUIRED.
- LIFT AND INSTALL STEEL BEAMS IN PAIRS (WITH GRP PLANKS IN PLACE) DURING RAILWAY POSSESSIONS. APPROX. WEIGHT OF EACH PAIR OF BEAMS IS 40 TO 45 TONNES. - DURING POSSESSION WORKS.
- CAST DIAPHRAGM AND DECK SLAB - OUTSIDE POSSESSION WORKING.
- INSTALL FORMWORK FOR THE DECK CANTILEVER CONSTRUCTION- DURING POSSESSION WORKING.
- CAST CANTILEVER DECK AND PARAPET PLINTH. - OUTSIDE POSSESSION WORKING.
- BACKFILL BEHIND ABUTMENT UP TO ROAD LEVEL OUTSIDE POSSESSION.
- INSTALL PARAPETS - DURING POSSESSION WORKING.
- INSTALL WATERPROOFING, KERBS, SURFACING, ETC. - OUTSIDE POSSESSION WORKING.

- KEY
- BT DUCT
 - INSTALCOM
 - NORTHUMBRIAN WATER COMBINED
 - NORTHUMBRIAN WATER FOUL
 - NORTHUMBRIAN WATER ABANDONED
 - NORTHUMBRIAN WATER SURFACE
 - NORTHUMBRIAN WATER TREATED
 - NORTHUMBRIAN WATER DISTRIBUTION
 - NON NORTHUMBRIAN WATER PRIVATE
 - NORTHERN GAS LOW PRESSURE
 - NORTHERN GAS MEDIUM PRESSURE
 - NORTHERN GAS INTERMEDIATE PRESSURE
 - NORTHERN GAS REGIONAL HIGH PRESSURE
 - VIRGIN MEDIA CABLE
 - NORTHERN POWER GRID CABLE
 - VODAFONE CABLE

SAFETY, HEALTH AND ENVIRONMENTAL SYMBOL LEGEND

⚠ INDICATES A RESIDUAL RISK AS A WARNING

Suit	Rev	Date	Description	Des	Chk	App

Designer
WSP BRINCKERS BRINCKERHOFF
 Three White Rose Office Park, Millshaw Park Lane, Leeds, LS11 0DL
 Tel: +44 (0)113 395 6200, Fax: +44 (0)113 395 6201
<http://www.wspgroup.com>

Client
highways england

Project Title
A1 BIRTLEY TO COAL HOUSE

Drawing Title
**ALLERDENE OPTION 3 - 2 SPAN
 GENERAL ARRANGEMENT
 (SHEET 1 OF 2)**

Scale	Drawn	Designed	Checked	Approved	Suitability
As shown @ 1:1	JW	JL	RM	HM	S0
Size	Date	Date	Date	Date	Revision
A1	XX/XX/XXXX	XX/XX/XXXX	XX/XX/XXXX	XX/XX/XXXX	
Status	PRELIMINARY				
Drawing Number					P0

WEST ABUTMENT

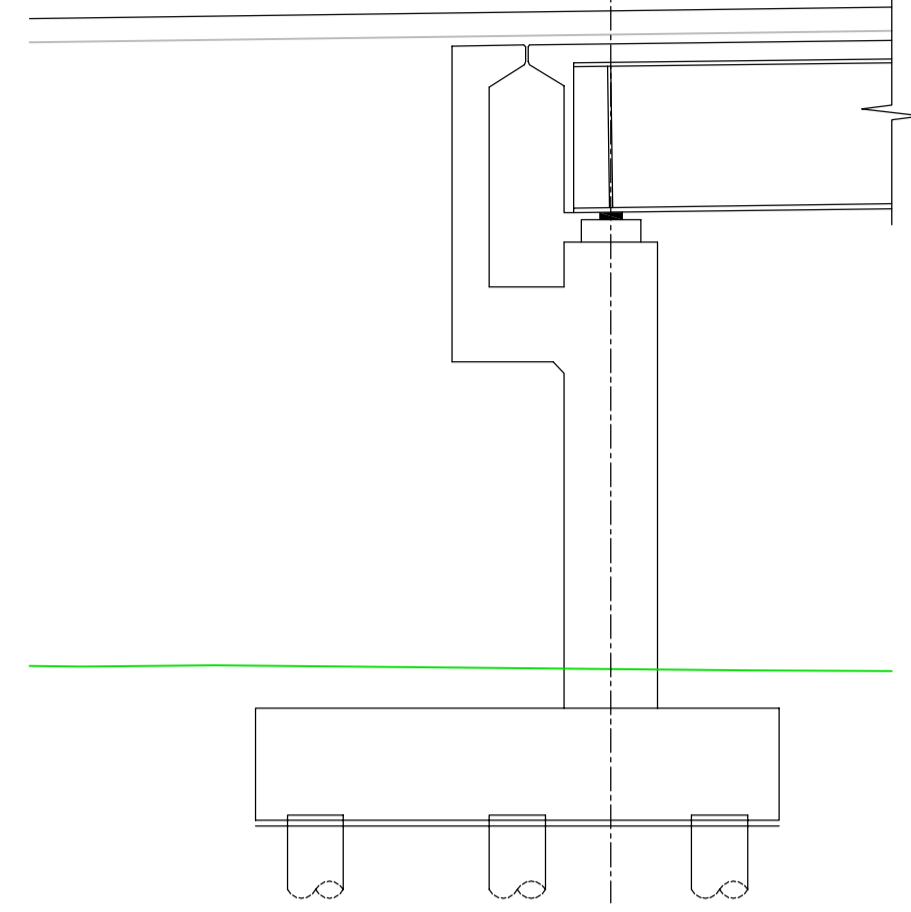

SECTION B-B
SCALE 1:100

PIER

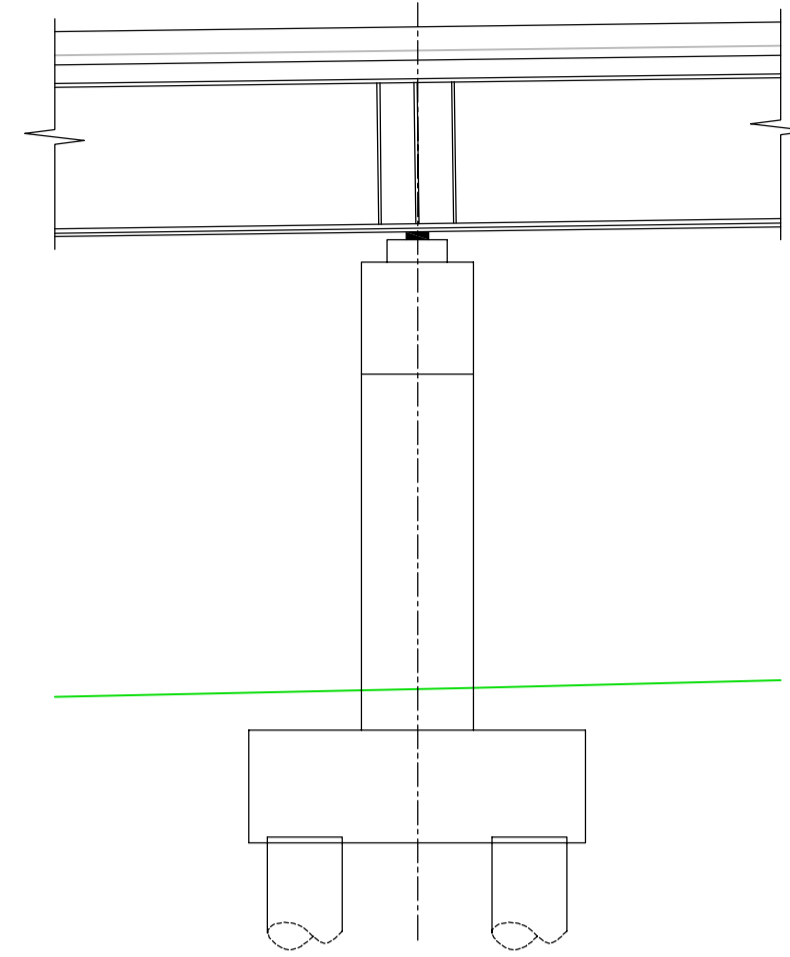

SECTION C-C
SCALE 1:100

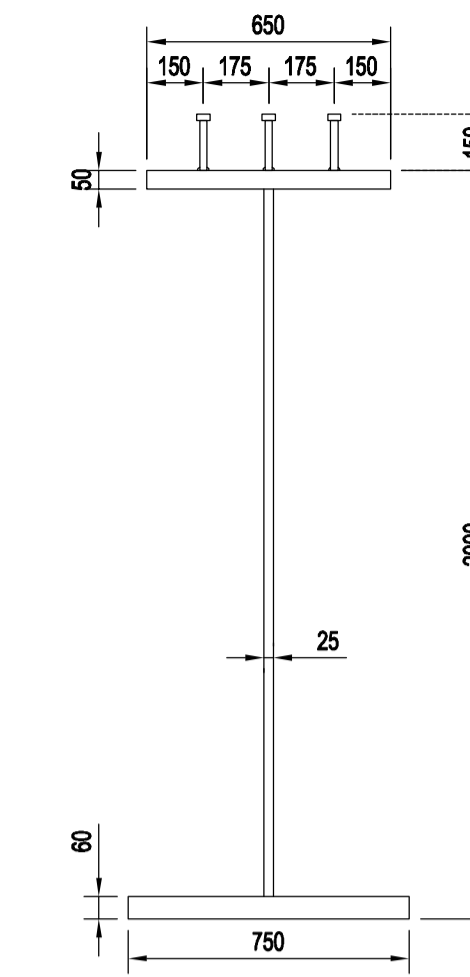

TYPICAL WEATHERING
STEEL GIRDER
SCALE 1:20

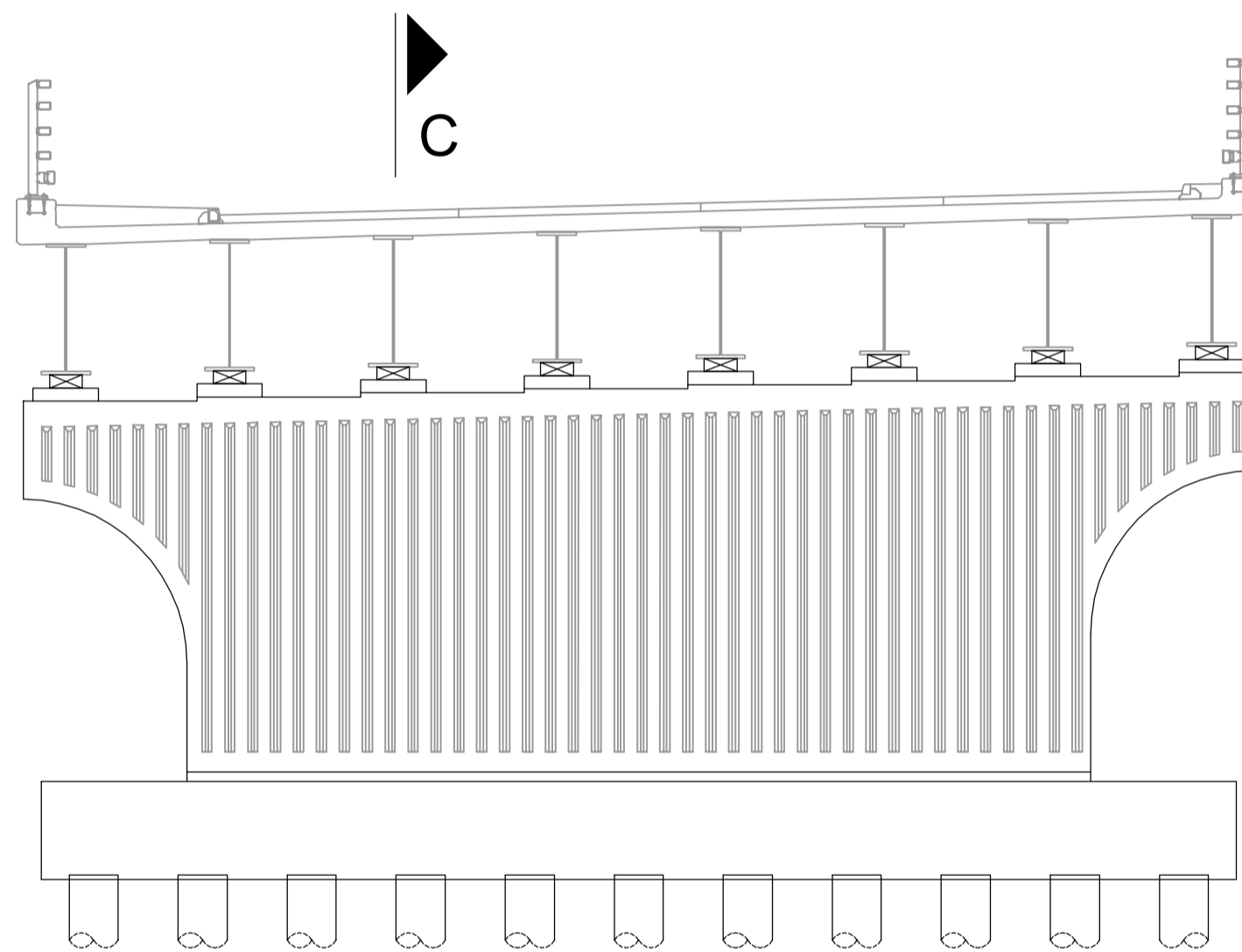

TYPICAL PIER ELEVATION
SCALE 1:100

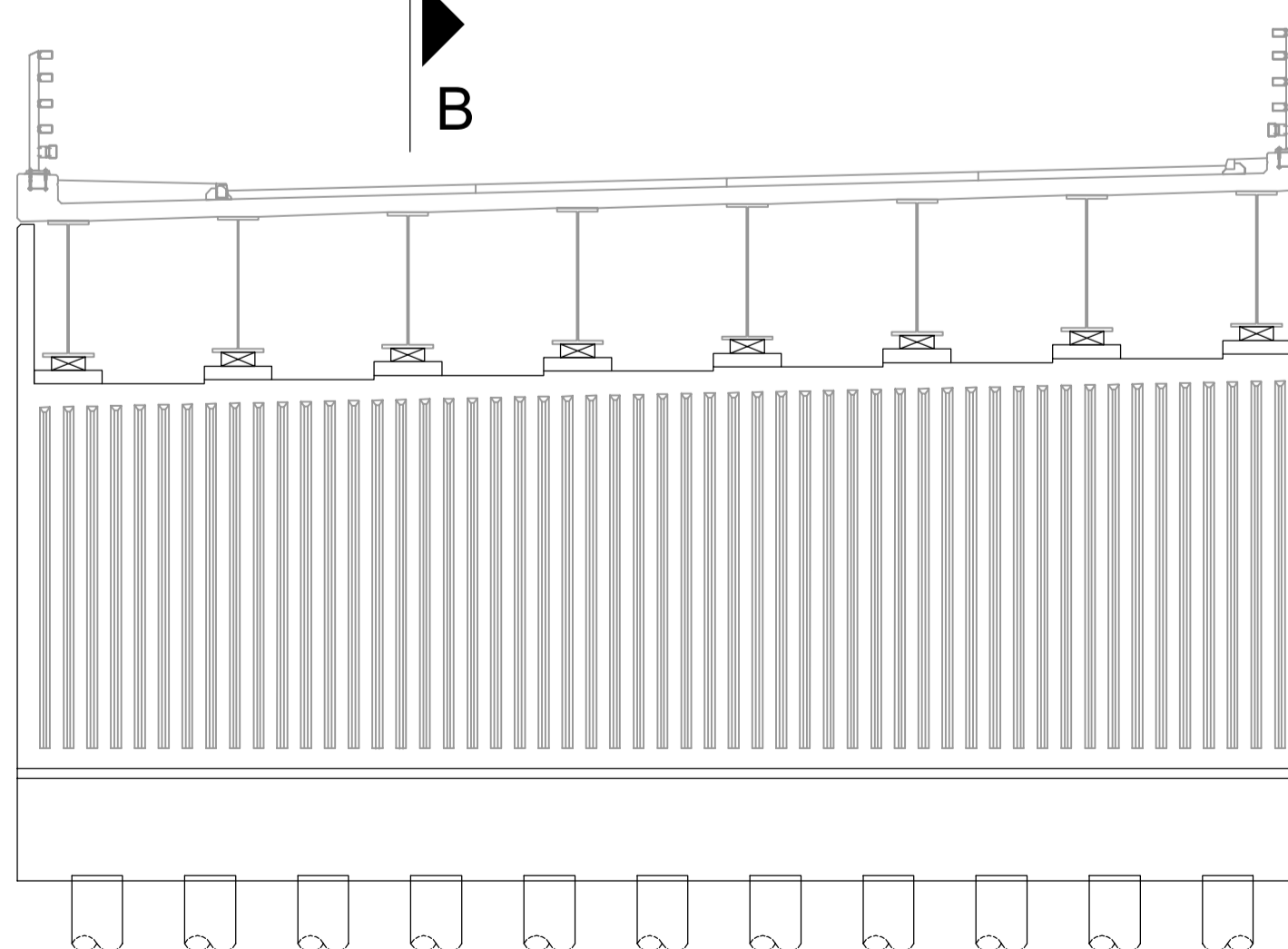

TYPICAL ABUTMENT ELEVATION
SCALE 1:100

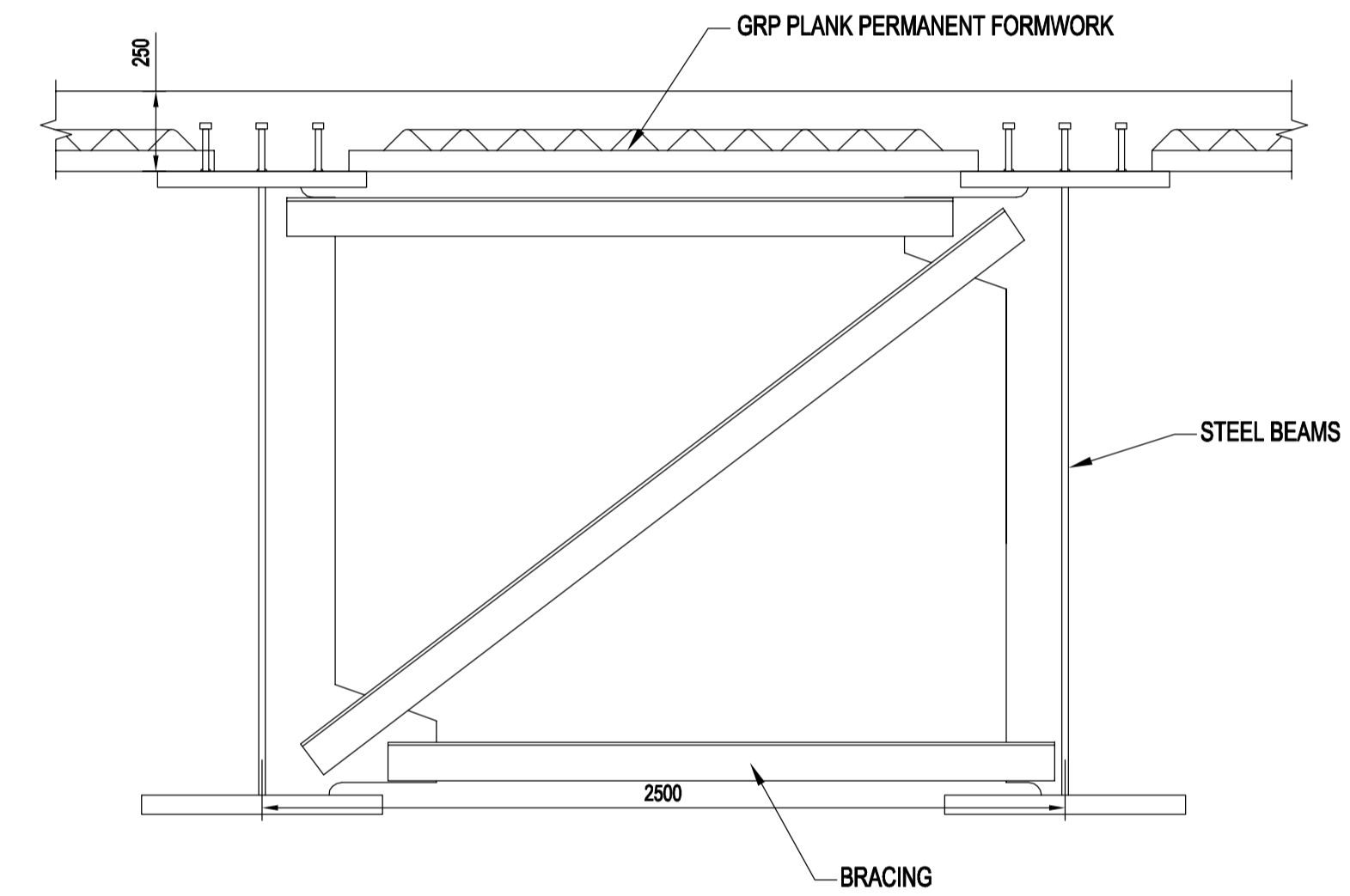

TYPICAL OMNIA PLANK DETAIL ON SOUTH DECK
SCALE 1:20

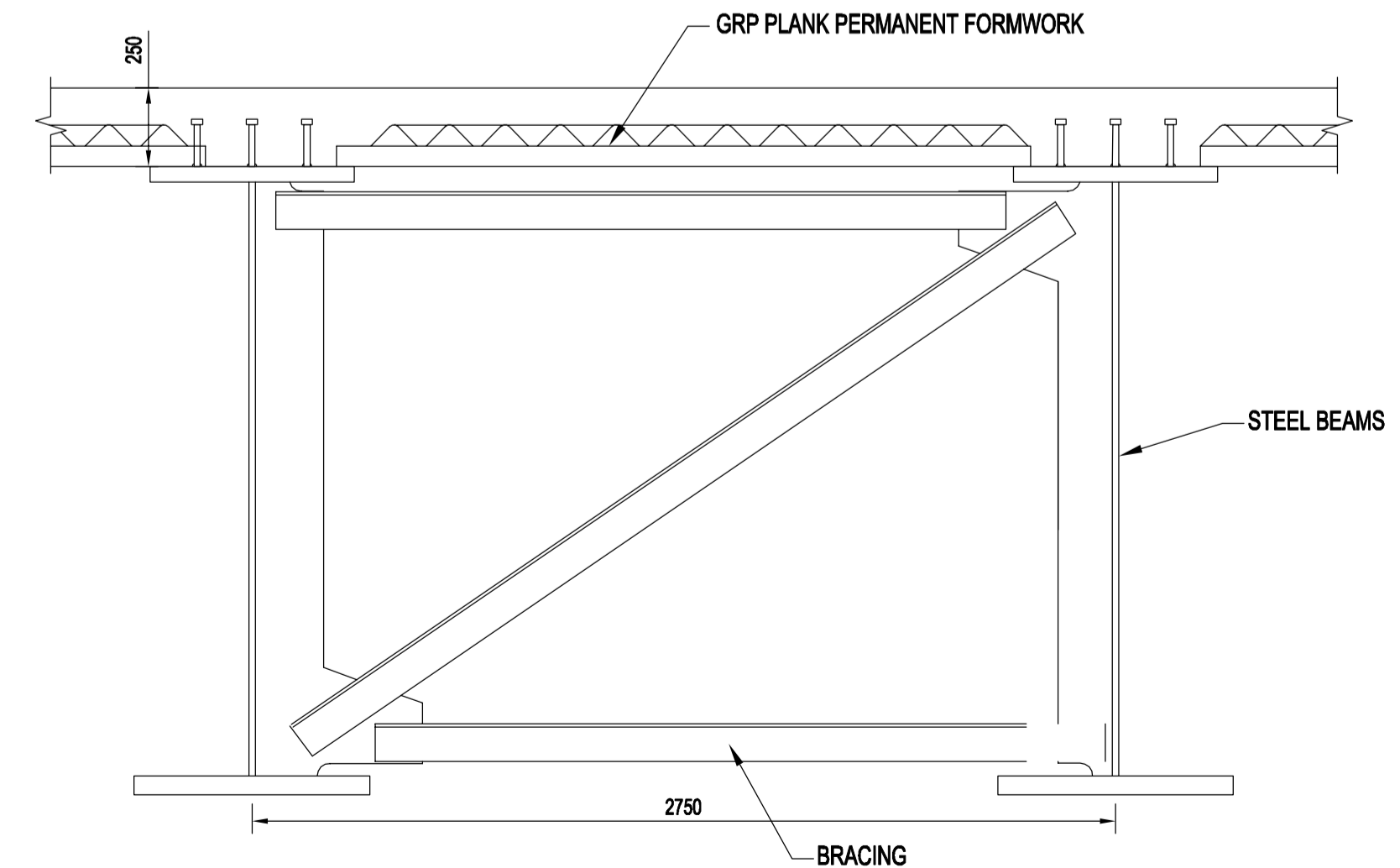

TYPICAL OMNIA PLANK DETAIL ON NORTH DECK
SCALE 1:20

NOTES

- REFER TO SHEET 1 OF 2 FOR GENERAL NOTES.

SAFETY, HEALTH AND ENVIRONMENTAL SYMBOL LEGEND

INDICATES A RESIDUAL RISK AS A WARNING

Stat	Rev	Date	Description	Des	Chk	App

Designer



Three White Rose Office Park, Millshaw Park Lane, Leeds, LS11 0DL
Tel: +44 (0)113 395 6200, Fax: +44 (0)113 395 6201
<http://www.wspgroup.com>

Client



Project Title

A1 BIRTLEY TO COAL HOUSE

Drawing Title

ALLERDENE OPTION 3 - 2 SPAN
GENERAL ARRANGEMENT
(SHEET 2 OF 2)

Scale	Drawn	Designed	Checked	Approved
AS SHOWN @ 1:1	JW	JL	RM	HM
Size	Date	Date	Date	Date
A1	XX/XX/XXXX	XX/XX/XXXX	XX/XX/XXXX	XX/XX/XXXX
Status	PRELIMINARY			
Drawing Number	-			
Suitability	S0			
Revision	P0			

Appendix G-4

ST004 THREE SPAN CONTINUOUS BRIDGE GA

A1

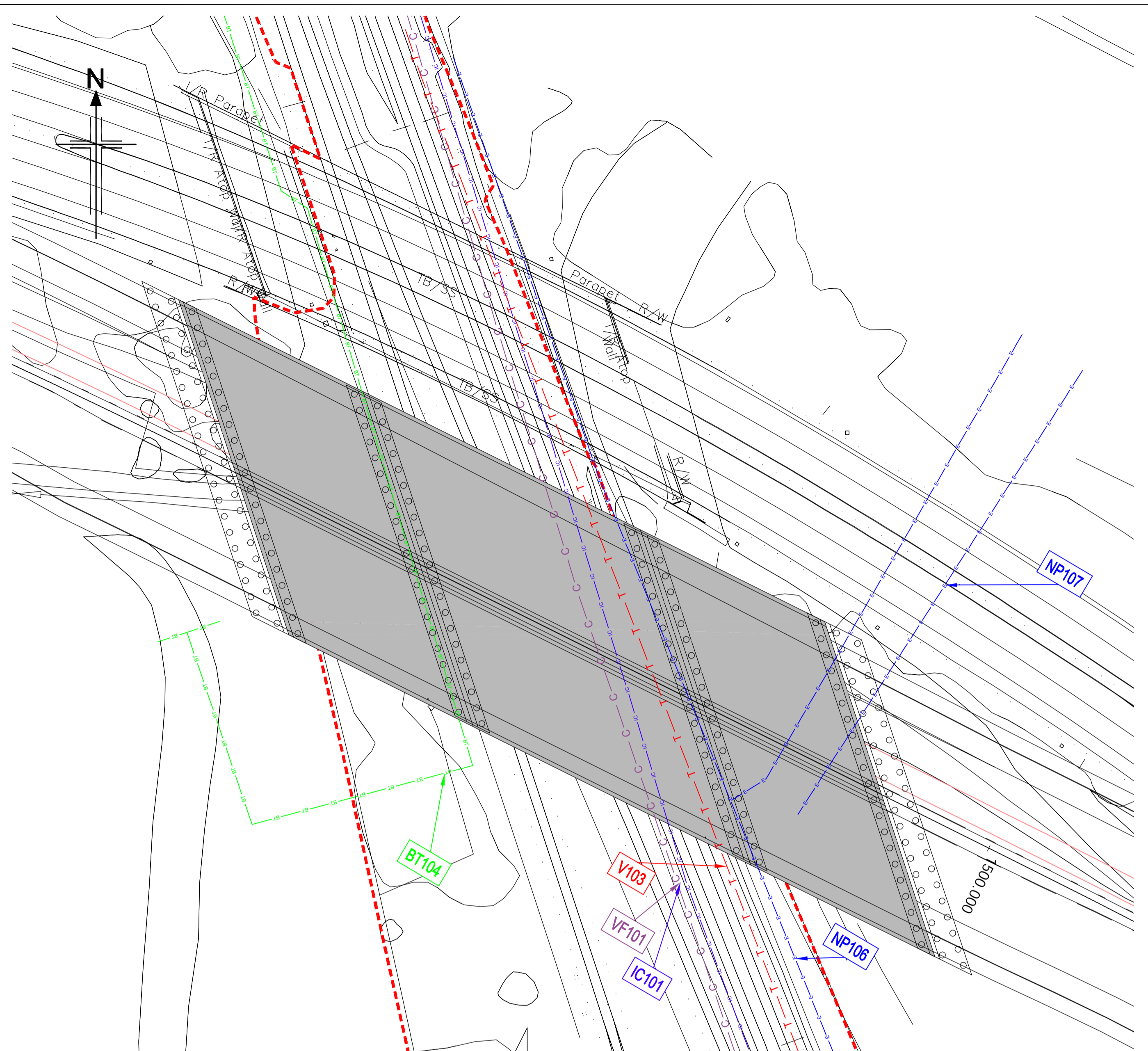

PLAN
SCALE 1:1000

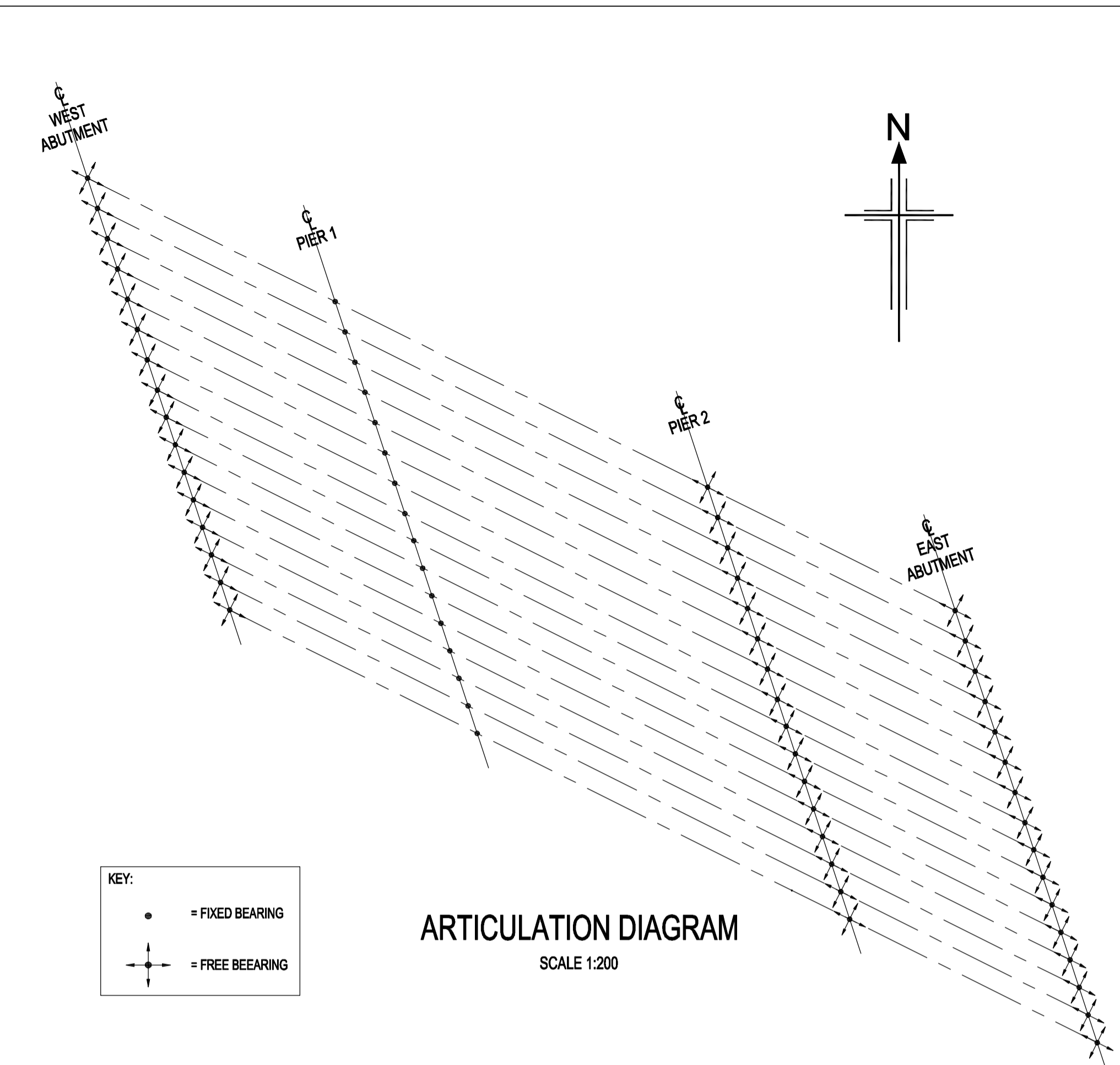

ARTICULATION DIAGRAM
SCALE 1:200

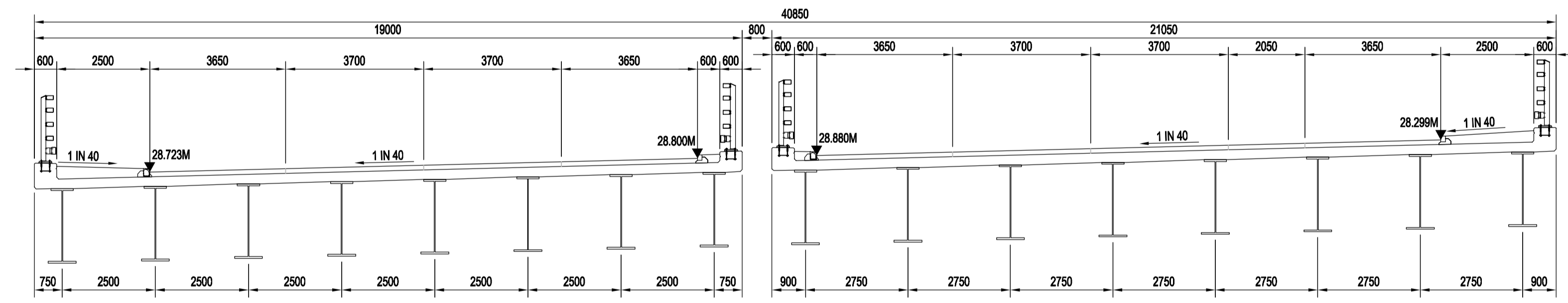

SECTION A-A
SCALE 1:100

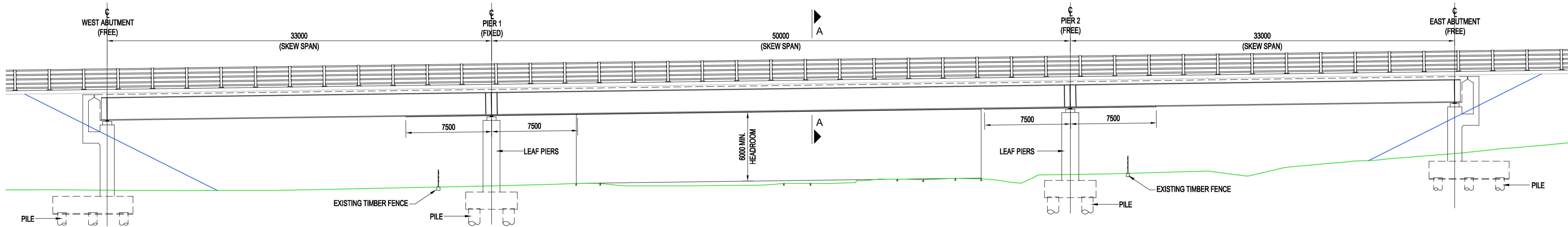

LONGITUDINAL ELEVATION
SCALE 1:200

- NOTES
- REFER TO SHEET 1 OF 2 FOR GENERAL NOTES.
 - STRUCTURAL STEELWORK TO BE BONDED AND EARTHED IN ACCORDANCE WITH NR/SPIELP21085 AND BS EN 50122-1.
 - THE STRUCTURAL STEELWORK SHALL BE ADEQUATELY BONDED AND EARTHED DURING CONSTRUCTION AND ON COMPLETION. THE STEELWORK IS BOLTED TOGETHER USING BRACING WHICH ON COMPLETION WILL PROVIDE ELECTRICAL CONTINUITY THROUGHOUT THE STRUCTURE FOR PASSAGE OF 25KV FAULT CURRENTS OF SHORT DURATION.

CONSTRUCTION SEQUENCE:
BELOW IS AN INDICATIVE CONSTRUCTION SEQUENCE OF KEY OPERATIONS FOR THE PROPOSED CONSTRUCTIONS OF THE BRIDGE. DETAILS ARE ALSO PROVIDED OF ANTICIPATED POSSESSION AND NON-POSSESSION WORKS.

- ESTABLISH SAFE WORKING AREA BY ERECTING A TEMPORARY FENCE ALONGSIDE THE RAILWAY TO PREVENT ACCESS TO AREAS CLASSED AS "ON OR NEAR THE LINE". (ERECTED IN ACCORDANCE WITH NETWORK RAIL STANDARDS AND WILL BE SUBJECT TO TEMPORARY WORKS APPROVAL). THIS IS REQUIRED TO PREVENT THE NEED FOR POSSESSIONS DURING FOUNDATION AND SUBSTRUCTURE WORKS.
- ESTABLISH PILING PLATFORM. INSTALL PILES - OUTSIDE POSSESSION WORKING.
- CAST THE REINFORCED CONCRETE PILE CAP - OUTSIDE POSSESSION WORKING.
- CAST THE REINFORCED CONCRETE ABUTMENT WALLS - OUTSIDE POSSESSION WORKING.
- INSTALL BEARINGS - OUTSIDE POSSESSION WORKING.
- BACKFILL BEHIND ABUTMENT UP TO BEARING SHELF LEVEL - OUTSIDE POSSESSION.
- DELIVER THE BEAMS ON SITE AND SPLICE AS REQUIRED.
- LIFT AND INSTALL STEEL BEAMS IN PAIRS WITH GRP PLANKS IN PLACE) DURING RAILWAY POSSESSIONS. APPROX. WEIGHT OF EACH PAIR OF BEAMS IS 40 TO 45 TONNES. - DURING POSSESSION WORKS.
- CAST DIAPHRAGM AND DECK SLAB - OUTSIDE POSSESSION WORKING.
- INSTALL FORMWORK FOR THE DECK CANTILEVER CONSTRUCTION- DURING POSSESSION WORKING.
- CAST CANTILEVER DECK AND PARAPET PLINTH. - OUTSIDE POSSESSION WORKING.
- BACKFILL BEHIND ABUTMENT UP TO ROAD LEVEL OUTSIDE POSSESSION.
- INSTALL PARAPETS - DURING POSSESSION WORKING.
- INSTALL WATERPROOFING, KERBS, SURFACING, ETC. - OUTSIDE POSSESSION WORKING.

KEY

	BT DUCT
	INSTALCOM
	NORTHUMBRIAN WATER COMBINED
	NORTHUMBRIAN WATER FOUL
	NORTHUMBRIAN WATER ABANDONED
	NORTHUMBRIAN WATER SURFACE
	NORTHUMBRIAN WATER TREATED
	NORTHUMBRIAN WATER DISTRIBUTION
	NON NORTHUMBRIAN WATER PRIVATE
	NORTHERN GAS LOW PRESSURE
	NORTHERN GAS MEDIUM PRESSURE
	NORTHERN GAS INTERMEDIATE PRESSURE
	NORTHERN GAS REGIONAL HIGH PRESSURE
	VIRGIN MEDIA CABLE
	NORTHERN POWER GRID CABLE
	VODAFONE CABLE

SAFETY, HEALTH AND ENVIRONMENTAL SYMBOL LEGEND
 INDICATES A RESIDUAL RISK AS A WARNING

Sat	Rev	Date	Description	Des	Chk	App

Designer

 Three White Rose Office Park, Millshaw Park Lane, Leeds, LS11 0DL
 Tel: +44 (0)113 395 6200, Fax: +44 (0)113 395 6201
 http://www.wspgroup.com

Client

Project Title
 A1 BIRTLEY TO COAL HOUSE

Drawing Title
 ALLERDENE OPTION 3 - 3 SPAN
 GENERAL ARRANGEMENT
 (SHEET 1 OF 2)

Scale	Drawn	Designed	Checked	Approved	Suitability
As shown @ 1:100	JW	JL	RM	HM	S0
Size	Date	Date	Date	Date	
A1	XX/XX/XXXX	XX/XX/XXXX	XX/XX/XXXX	XX/XX/XXXX	
Status	PRELIMINARY				
Drawing Number					Revision
					P0

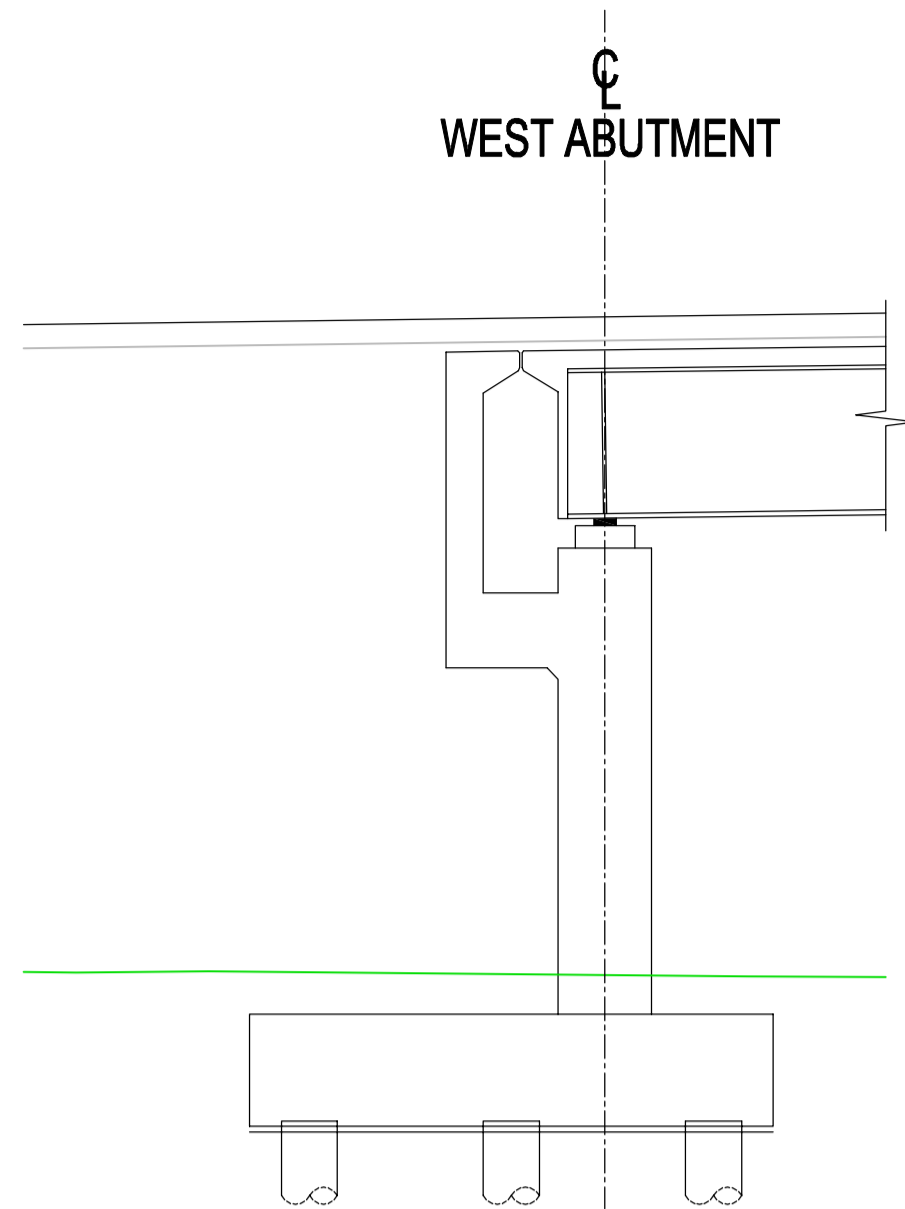

SECTION B-B
 SCALE 1:100

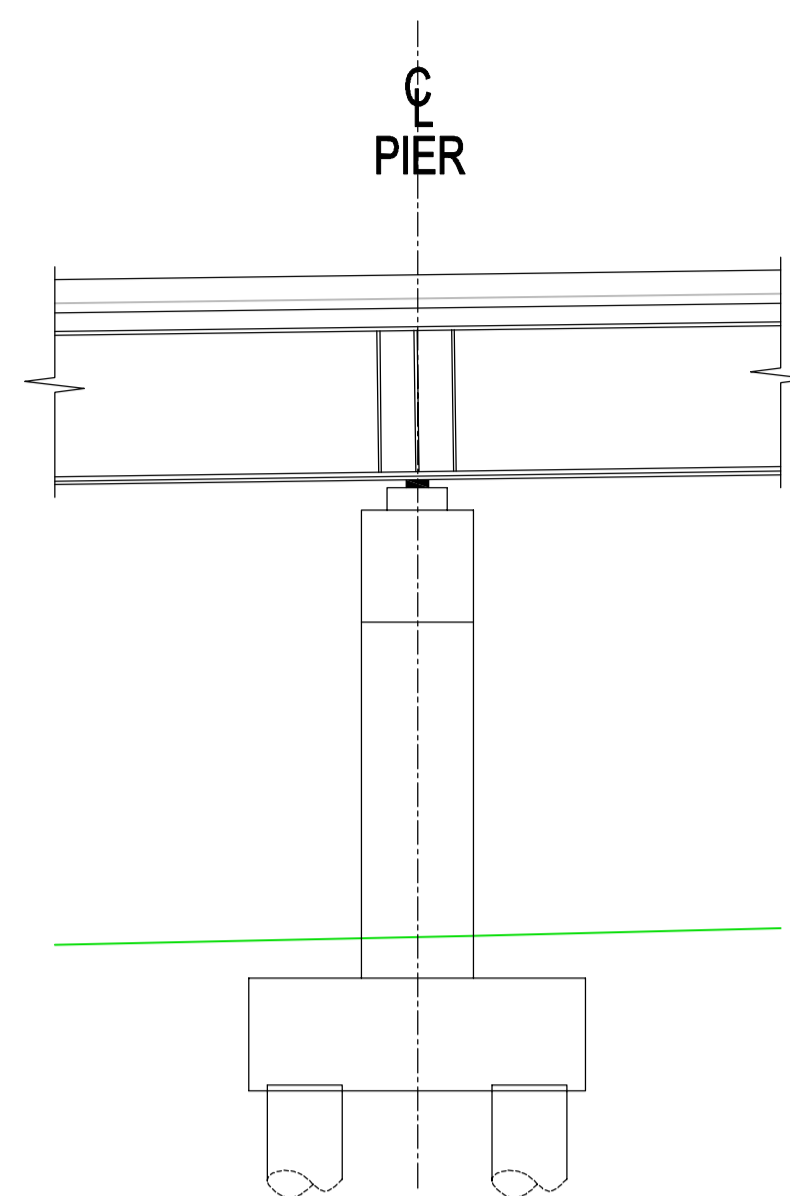

SECTION C-C
 SCALE 1:100

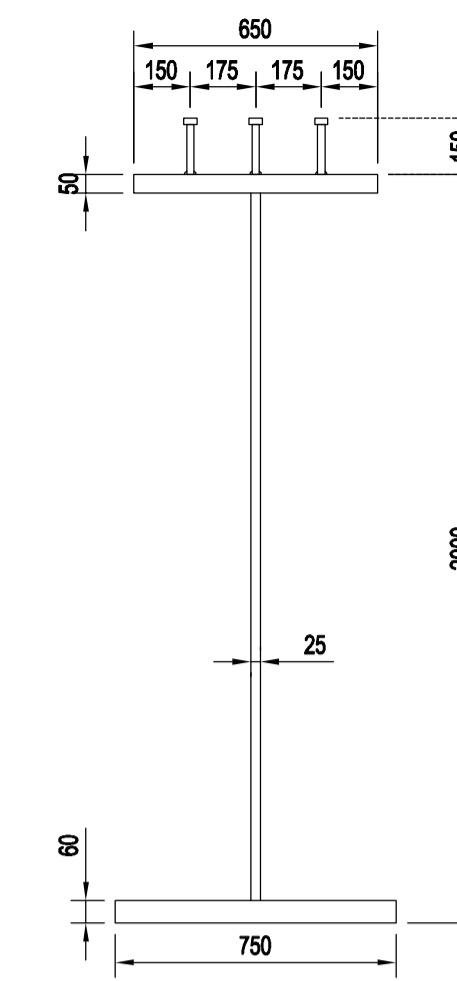

TYPICAL WEATHERING
 STEEL GIRDER
 SCALE 1:20

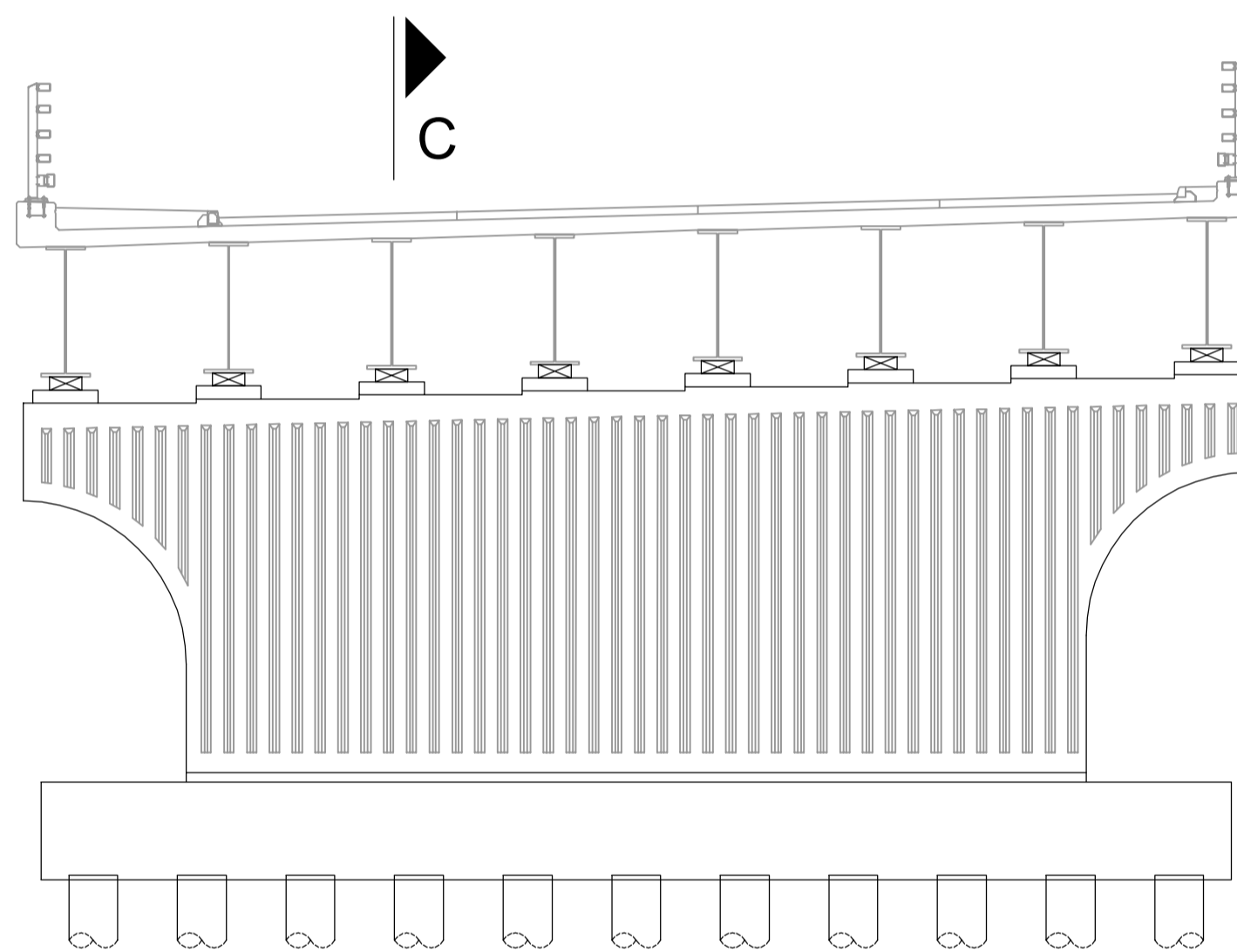

TYPICAL PIER ELEVATION
 SCALE 1:100

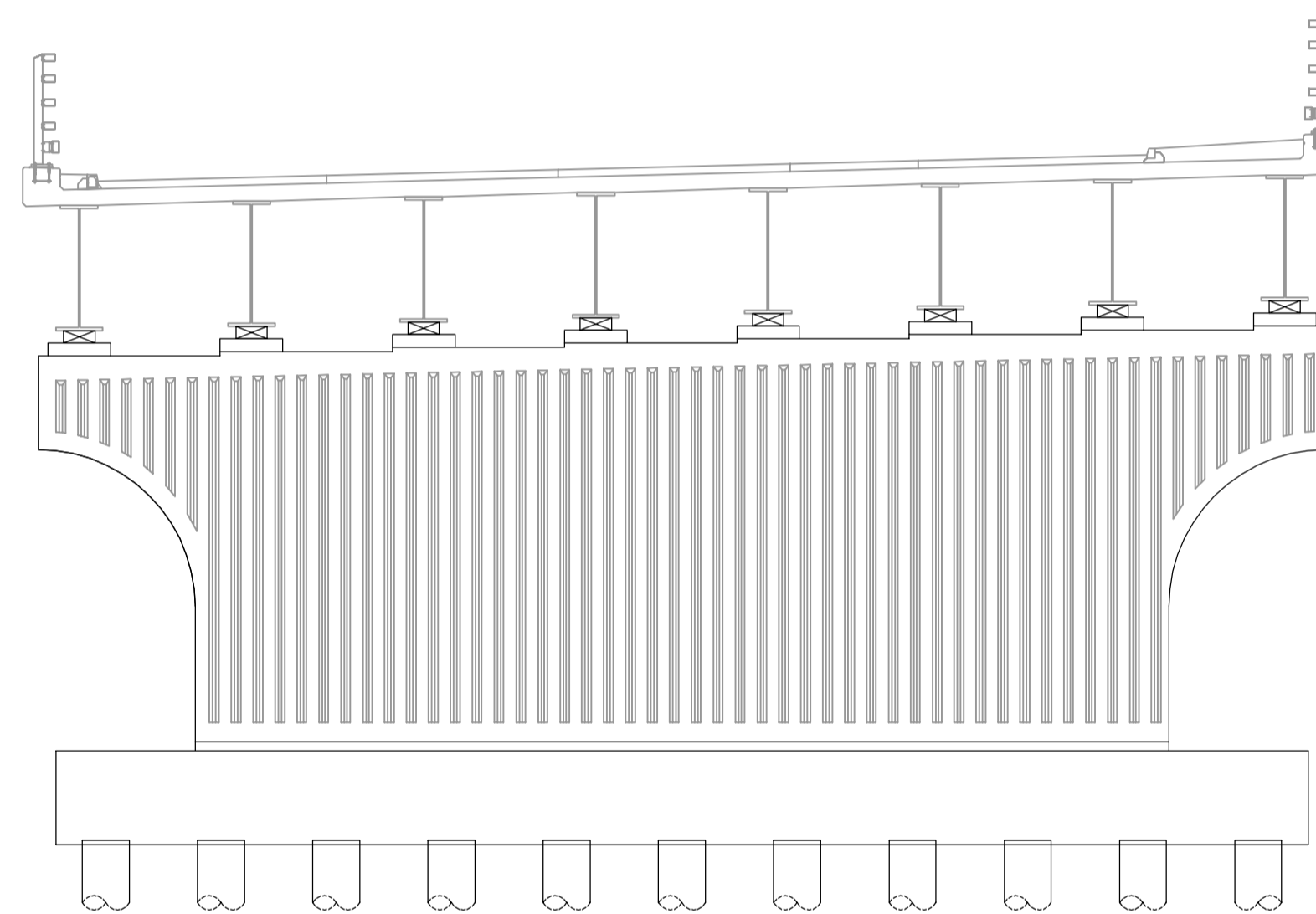

TYPICAL ABUTMENT ELEVATION
 SCALE 1:100

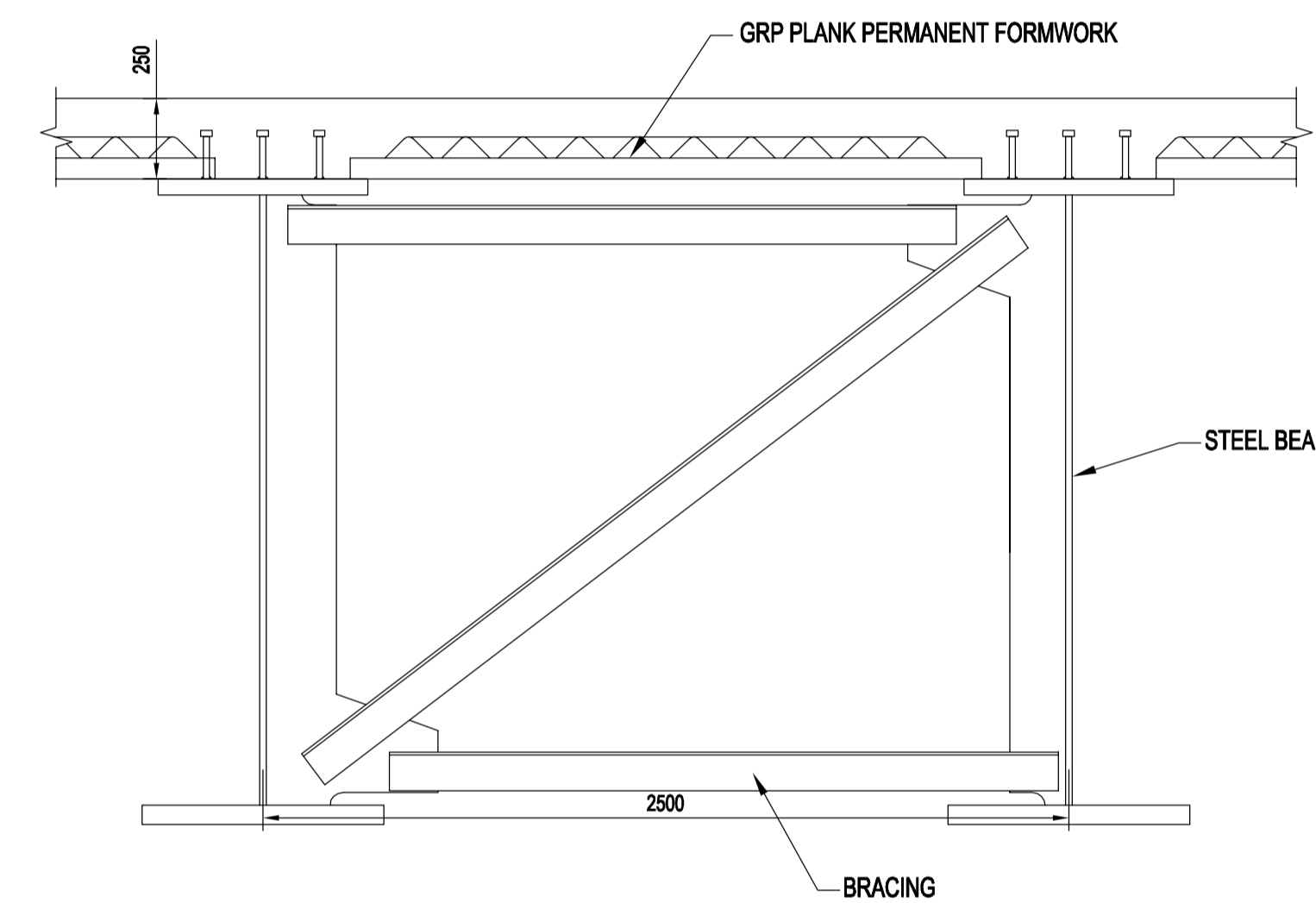

TYPICAL OMNIA PLANK DETAIL ON SOUTH DECK
 SCALE 1:20

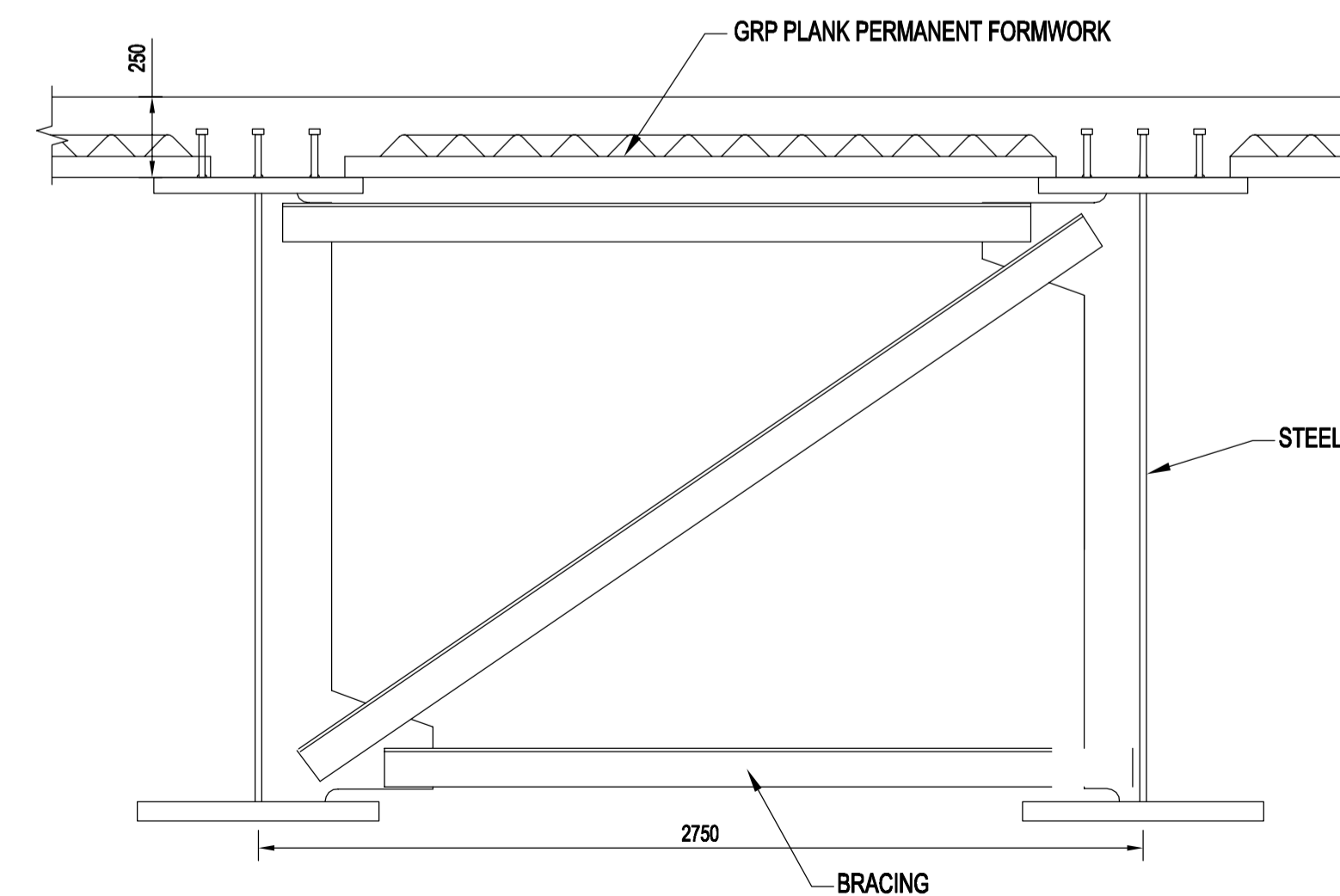

TYPICAL OMNIA PLANK DETAIL ON NORTH DECK
 SCALE 1:20

NOTES

- REFER TO SHEET 1 OF 2 FOR GENERAL NOTES.

SAFETY, HEALTH AND ENVIRONMENTAL SYMBOL LEGEND

▲	INDICATES A RESIDUAL RISK AS A WARNING

Stat	Rev	Date	Description	Des	Chk	App

Designer
WSP PARSONS BRINCKERHOFF
 Three White Rose Office Park, Millshaw Park Lane, Leeds, LS11 0DL
 Tel: +44 (0)113 395 6200, Fax: +44 (0)113 395 6201
<http://www.wspgroup.com>

Client
highways england

Project Title
A1 BIRTLEY TO COAL HOUSE

Drawing Title
**ALLERDENE OPTION 3 - 3 SPAN
 GENERAL ARRANGEMENT
 (SHEET 2 OF 2)**

Scale	Drawn	Designed	Checked	Approved
AS SHOWN (A1)	JW	JL	RM	HM
Size	Date	Date	Date	Date
A1	XX/XX/XXXX	XX/XX/XXXX	XX/XX/XXXX	XX/XX/XXXX
Status	PRELIMINARY			
Drawing Number	-			
Suitability	S0			
Revision	P0			

Appendix H

COSTAIN BUILDABILITY REVIEW – OPTIONS ST001-ST004

Appendix H-1

**COSTAIN BUILDABILITY REVIEW – OPTIONS
ST001-ST004**

Costain has been asked to review four bridge options to replace the existing Allerdene Bridge carrying the existing A1 over the East Coast Mainline (ECML). All the Options (ST001-004) are on off-line solution.

Recommended Pre-Constructon activites

1. Complete all land purchases and legal agreements with Network Rail (NR) in advance of the works.
2. Statutory Undertakers diversions need to be completed before construction works begin.
3. The gas main should be diverted ahead of the bridge construction works commencing.
4. Agreements with Network Rail (NR) regarding land access issues are completed and adequate.
5. Extensive GI needed. See the drawings produced for the construction of Allerdene Bridge for extent of grouting and mine workings.
6. Agree and install any NR track monitoring equipment. Agree and complete any condition surveys of OLE or trackside equipment.
7. Exam/Inspect the abandoned Underground Gas Storage Cellars. Their construction is unknown.

Construction sequence.

Enabling works

1. The A1 northbound carriage way requires traffic management to allow narrow lane running. This creates a safety zone ahead of installation of temporary works as detailed further below.
2. Additional barriers are needed on the offside of the existing northbound carriageway to provide an enhanced Vehicle Restraint System next to the railway and excavations.
3. Site clearance and preparation of the working area under the footprint of the new bridge and road alignment. This includes preparation of piling platforms for new foundation construction and installation of sheet piles for temporary works to support the existing northbound carriageway.
4. Construct access roads to both sides of the railway for labour, plant and materials. Construct lay down areas for storage and assembly of materials such as formwork and reinforcement. Establish office, welfare and parking facilities on both side of the railway.
5. Establish and install all NR protection including fencing, hoarding to establish safe working zones. Erect fence 3m from infrastructure.
6. Take possession of all land required adjacent and within the railway as agreed or purchased as part of the works.

7. Install sheet piling temporary works to the offside of the existing northbound carriageway to support the carriage way during construction of the new bridge. These sheet piles will probably be anchored back under the existing carriageway. A piling platform may be required. Construction of this platform and a piling method will need agreement with NR as it is in the vicinity of the railway and at existing road level.

Foundation Construction.

1. Ground strengthening / void grouting works.
2. Pile installation. A safe method of working is required to prevent piling rig overturning onto the railway. Piles are required for the wing walls as well. Consideration should be given to pile location to allow access for their construction.
3. Pile cap construction. The pile cap needs to be constructed as close to the railway as possible to reduce the overall span of the bridge. Temporary works (sheet piles) may be required to support the railway land whilst allowing the piles to be broken down and blinding to be placed. Back blinding to the vertical face of the pile cap adjacent to the railway is another ground support option. Breaking down of new piles. RC works to pile cap. Concrete pour. Waterproofing and backfill. Ensure adequate compaction and safe provision of earthworks materials to the excavated area.

Abutment, Wing Wall, Leaf Pier and Bank Seat Construction.

1. All insitu reinforced concrete works .Ensure pour heights are designed into the build sequence. This may also effect reinforcement design of rebar lengths and mechanical connection details rather than lap lengths. Shutter height design to meet requirements to prevent incursion on to the railway in the event of failure.
2. Design of the reinforced concrete structures are to consider imposed loads from cranes used either during construction of the new bridge or deconstruction of the old bridge at a later date.

Bridge Deck Construction.

Options 2, 3 and 4 all require the construction of an insitu concrete deck on steel beams. The beams are to be lifted in to position in pairs. Due to their size the beams need to be brought to site individually. A fabrication area is therefore required on site where the beams can be joined into pairs for lifting in to position. A transportation method is also needed to bring the paired beams to the lifting location within the lift radius of the crane(s).

Depending on the option chosen and further design development the suitability of the following methods can be continually assessed. The maximum weight of the paired beams with associated pre-installed temporary works is the main governing factor along with lift radii determining the choice and capacity of the required lifting equipment.

It is proposed that the paired beams would all be lifted into position during railway possessions. This is effectively from 01:00 to 05:00 Saturday night. One pair of beams would be lifted in to place during each possession. There are eight pairs of beams so eight possessions are required. Contingency possessions are also required for risks such cancellation due to weather or NR requirements and restrictions.

Option 2 - Variation A.

Tandem lift with mobile cranes

It is proposed to use the lifting capability of the largest telescopic mobile cranes available in the UK working in tandem. These are LTM11200 mobile cranes .

For this Option the fabrication yard would be on the alignment of the new carriageway between Allerdene Bridge and Smithy Lane Bridge. The paired beams would have to be delivered to the existing northbound carriageway on SPMT's. This would require closure of the existing northbound carriageway. An overnight diversion of traffic is required or contraflow could be installed on the existing southbound carriageway.

The tandem lifting cranes can install all the new southbound carriageway beams assuming pairs of beams are delivered to the 'pick up location' on the closed northbound carriageway. They can also install two of the paired beams on the new northbound carriageway using the same positions. See Sketch 01 below.

In order to facilitate the installation of the final two pairs of beams they would need to be double handled. This means lifting both remaining pairs of beams to a temporary staging location. The preinstalled new northbound pairs 1 and 2 would be utilised. By temporarily setting down the final two pairs of beams on them it will allow the repositioning one of the LTM11200 machines to increase capacity for the final install.

Once repositioned the two cranes will have the capacity to lift the beams from the temporary set down location and relocate them into their permanent position. See Sketch 02 below.

Schedule

Mob and setup 2 x LTM11200	- 1 day
Install pair of bridge beams New Southbound 1 closure	- 1 night
Install pair of bridge beams New Southbound 2 closure	- 1 night
Install pair of bridge beams New Southbound 3 closure	- 1 night
Install pair of bridge beams New Southbound 4 closure	- 1 night
Install pair of bridge beams New Northbound 1 closure	- 1 night
Install pair of bridge beams New Northbound 2 closure	- 1 night
Temporarily position bridge beams New Northbound 3 and 4 onto New Northbound 1 and 2	- 1 night closure
Reposition west side LTM11200	- 1 day
Install pair of bridge beams New Northbound 3 closure	- 1 night
Install pair of bridge beams New Northbound 4 closure	- 1 night
Demob and disassemble 2 x LTM11200	- 1 day

The relative disadvantage of the telescopic mobile option is that these cranes are lifting at near capacity with just the weight of the beams. Temporary works may not be accommodated in the weight of the lift. Additionally there are few of these machines in the UK which may cause availability issues. With the restriction of working over multiple Saturday night possession periods the relative cost of keeping the two mobile cranes will be high in comparison with a suitable crawler crane.

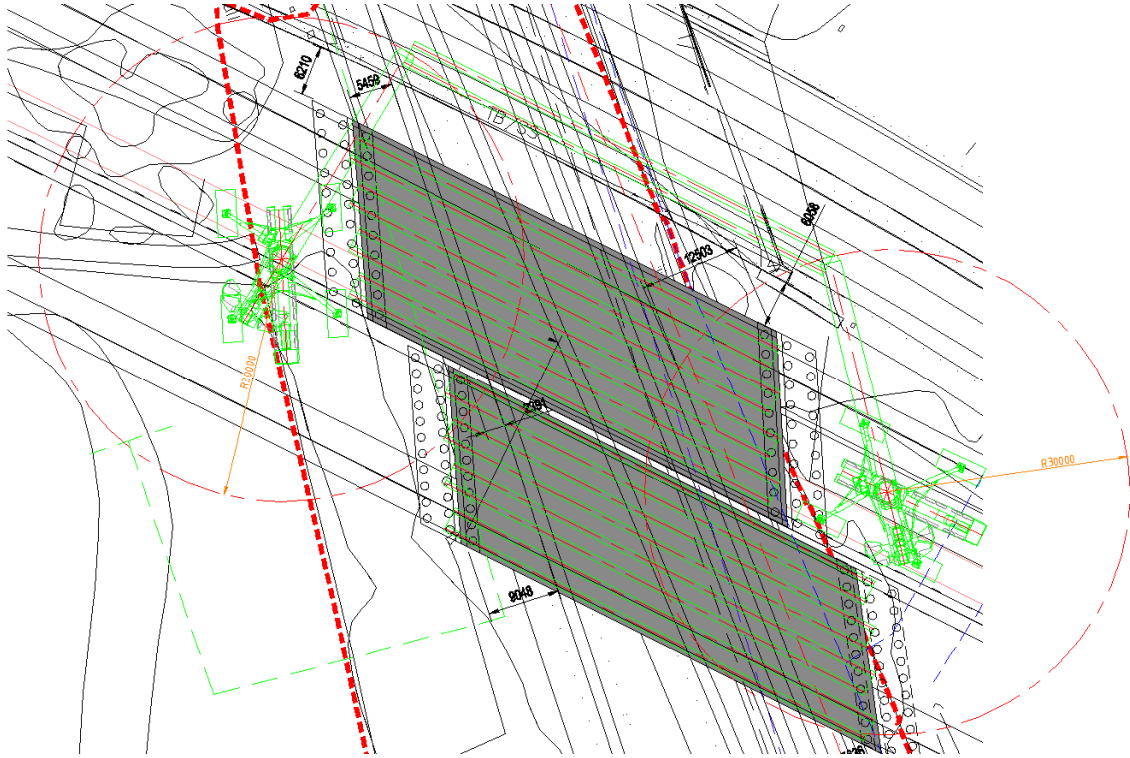

SKETCH 01. Crane can place all the s/b bridge beams. And the two most northerly pairs of beams on the new north bound bridge. The two most southerly pairs of beams are 'stored' on those of the newly place most northerly pair of the new n/b structure. See sketch 02 below for the next stage.

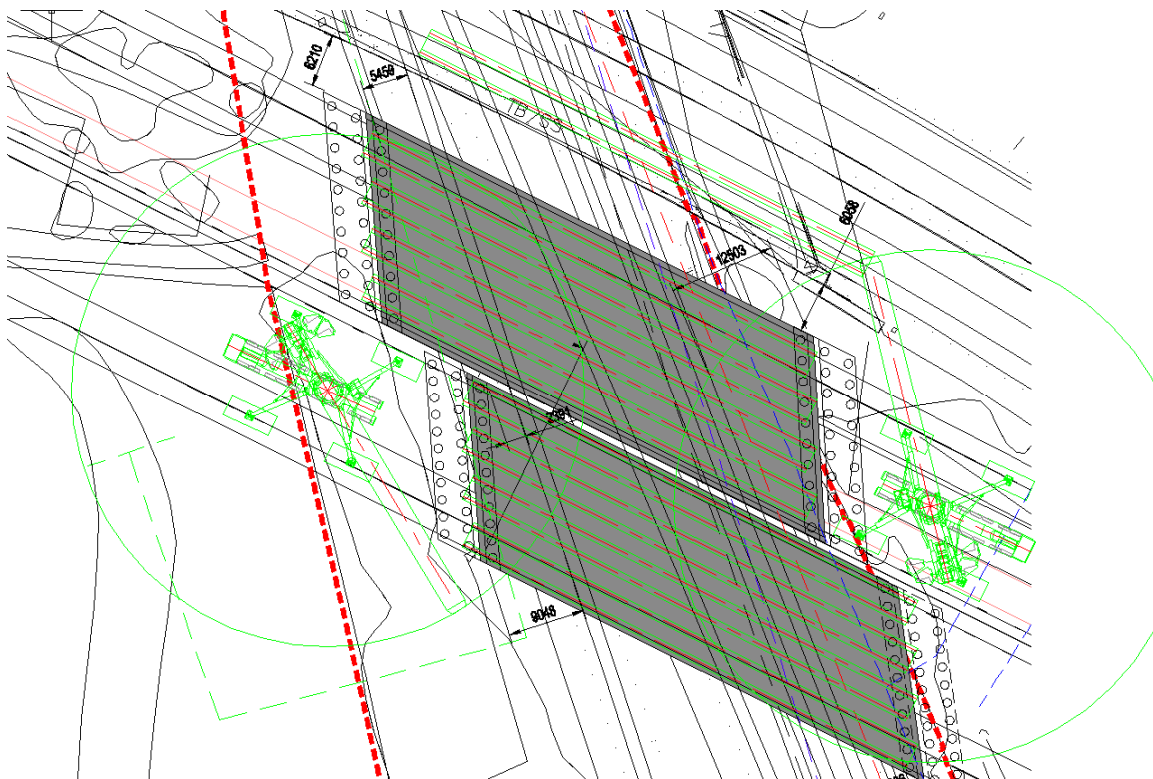

SKETCH 02. West crane relocated to allow beams to be moved from 'storage' on the initial two beam pairs of the new N/b structure. These two pairs of beams are lifted in to position completing the beam lifts.

Option 2 – Variation B

Single lift via crawler crane.

A suitably sized crawler crane could perform all of the lifts from a single location. The crane's increased capacity could accommodate the installation GRP panels as soffit formwork, parapet beam falsework and bracing.

A LR1750 crawler crane is proposed to install all of the paired beams from the east side of the new southbound carriageway. See Sketch 03 below. This machine would require some additional days to setup but is a more economical option overall assuming the beam installation would still be completed over consecutive weekends. For this Option the fabrication yard would again be on the alignment of the new carriageway between Allerdene Bridge and Smithy Lane Bridge.

The crawler crane can install all the new beams assuming pairs of beams are delivered to the 'pick up location' on the closed northbound carriageway.

Schedule

Mob and setup LR1750	– 5 days
Install pair of bridge beams New Southbound 1 closure	– 1 night
Install pair of bridge beams New Southbound 2 closure	– 1 night
Install pair of bridge beams New Southbound 3 closure	– 1 night
Install pair of bridge beams New Southbound 4 closure	– 1 night
Install pair of bridge beams New Northbound 1 closure	– 1 night
Install pair of bridge beams New Northbound 2 closure	– 1 night
Install pair of bridge beams New Northbound 3 closure	– 1 night
Install pair of bridge beams New Northbound 4 closure	– 1 night
Demob and disassemble LR1750	– 5 days

The crawler crane option will be more viable. This crane does need significantly more notice than the mobile cranes and may need to be mobilised from Europe but with early planning availability should not be an issue. Six to eight months is recommended as the minimum advanced booking period.

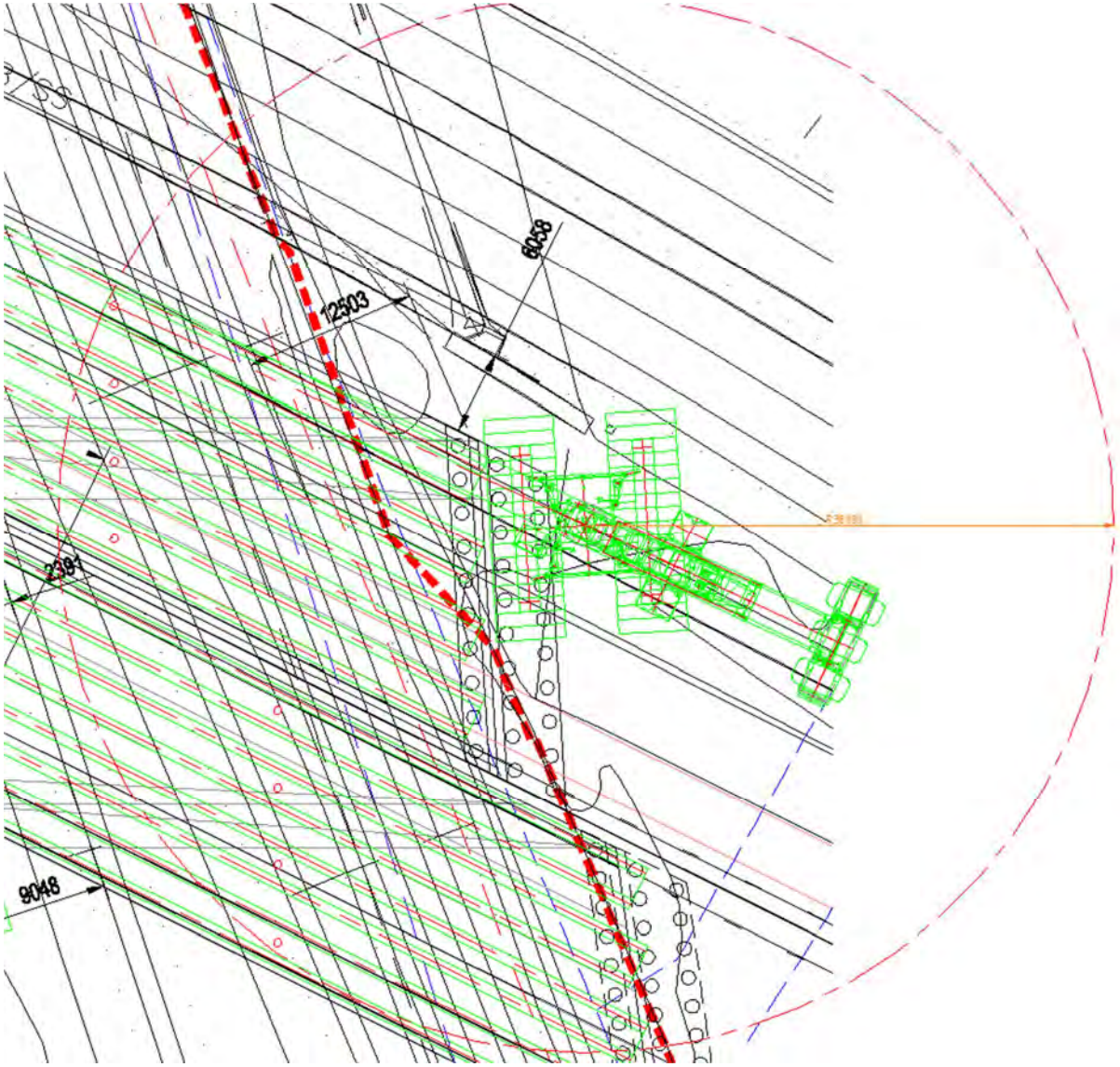

ST003 – 2 Span bridge.

The addition of the second span for this option means that the ground to the west of the central support is not raised. The land remains at about track level for future possible expansion by the railway.

A crane situated in this location that could place beams over the railway span and second span would be ideal. The two abutments could be constructed and beams placed without the need for backfilling before beam placement. It is proposed to use an LR1600 crawler crane in this instance. This is possible as the railway span is reduced to 50m on this option.

SPMT's would be required to bring paired beams to the crane for lifting. They would be brought to the rear of the west abutment and lifted off the SPMT's on a relatively short radius. As the crane slewed additional 'superlift' counterbalance would allow the crane to jib out further to place the beams at a greater radius. A governing factor in this choice of solution is the 33m working room allowing space for the crane and additional counter weight. The attached LR1600-2 Data Sheet illustrates the relationship of the crane and superlift counter balance.

It is proposed to install a pair of 50m beams during a possession and then immediately install the corresponding 33m section outside of the possession assuming lifting next to the track outside of possession. Once both pairs of beams are installed the crane would crawl back ready to install the next set of pairs during the following possession.

With this option a similar schedule to that advised previous would apply assuming the 33m span lift can take place outside of the possession lift window.

Schedule

Both spans

Mob and setup LR1600	- 5 days
Install pair of bridge beams New Southbound 1 + 33m span night closure	- 1
Install pair of bridge beams New Southbound 2 + 33m span night closure	- 1
Install pair of bridge beams New Southbound 3 + 33m span night closure	- 1
Install pair of bridge beams New Southbound 4 + 33m span night closure	- 1
Install pair of bridge beams New Northbound 1 + 33m span night closure	- 1
Install pair of bridge beams New Northbound 2 + 33m span night closure	- 1
Install pair of bridge beams New Northbound 3 + 33m span night closure	- 1
Install pair of bridge beams New Northbound 4 + 33m span night closure	- 1
Demob and disassemble LR1600	- 5 days

ST004 – 3 Span Bridge.

The 3 span option would be similar to Option 3. The central span over the railway and the west span would be installed as Option 3.

The east span beams can be installed using an LTM1750 mobile crane. Assuming the east span beams can be installed out of possession as they aren't above the railway it would be possible to install the eight 8no. 33m span paired beams in say eight days. Additional time may be required to allow the beams to be brought to site, paired and temporary works added. Just in time planning of this activity could reduce the construction period and crane costs.

The additional schedule for the smallest suitable crane to install the east beams load is provided below. A lighter load for the 33m spans is likely so perhaps a smaller crane could be used in this instance.

Schedule

West and central span.

Mob and setup LR1600	– 5 days
Install pair of bridge beams New Southbound 1 + 33m span West night closure	– 1
Install pair of bridge beams New Southbound 2 + 33m span West night closure	– 1
Install pair of bridge beams New Southbound 3 + 33m span West night closure	– 1
Install pair of bridge beams New Southbound 4 + 33m span West night closure	– 1
Install pair of bridge beams New Northbound 1 + 33m span West night closure	– 1
Install pair of bridge beams New Northbound 2 + 33m span West night closure	– 1
Install pair of bridge beams New Northbound 3 + 33m span West night closure	– 1
Install pair of bridge beams New Northbound 4 + 33m span West night closure	– 1
Demob and disassemble LR1600	– 5 days

East span.

Mob LTM1750 mobile crane	– 1 day
Install pair of bridge beams New Southbound 1 33m span East	– 1 day
Install pair of bridge beams New Southbound 2 33m span East	– 1 day
Install pair of bridge beams New Southbound 3 33m span East	– 1 day
Install pair of bridge beams New Southbound 4 33m span East	– 1 day
Install pair of bridge beams New Northbound 1 33m span East	– 1 day
Install pair of bridge beams New Northbound 2 33m span East	– 1 day
Install pair of bridge beams New Northbound 3 33m span East	– 1 day
Install pair of bridge beams New Northbound 4 33m span East	– 1 day
Demob LTM1750	– 1 day

ST001 –Network Arch bridge: Complete bridge launch

Option 1 requires the installation of two tied arch bridge structures, one for each carriageway. The tied arch structures need to be slid into position across the railway. Each structure is likely to need a nose and tail – that is additional steel work cantilevered in front of the bridge, to aid sliding and landing the nose, and at the rear to act as a counter balance.

Sliding this structure will need a temporary central pier situated in the railway land most likely between the two central lines. Working on the railway is a risk the contract should avoid if possible. Construction of a central pier and its following deconstruction after use are significant additional risks and items requiring considerable additional design. Additional possessions are required for these works. The existing OLE adds another hazard. The risks associated with these works have previously been recorded elsewhere in the risk register, are well known and should be avoided.

Ideally this bridge would be built as one structure and slid into position. Given the curvature of the existing road layout and the overall length of the structures it is practical to construct a bridge for each carriageway. The bridges would need to be constructed in line with the launch direction. This would be on the west approach to the new northbound structure.

The southbound structure would be built first on the proposed northbound carriageway. It would be launched from this position onto the north bound abutments. From the north abutments it would be 'skidded' over the abutments in a northerly direction to its final position.

Once installed the same operation for the new northbound structure is repeated except the 'northerly skidding' isn't required.

Building the structures consecutively requires significant additional time in the programme. An improvement could be made if the structures could be built concurrently and adjacent to each other. To create the extra space required significant additional earthworks would be required. A 'platform' would be built effectively being an 'extra-wide' hard shoulder on embankment to the proposed northbound A1 carriageway north of Allerdene Bridge. Detailed planning would be needed to assess the buildability, risks and craneage requirement to allow the two structure to be built in this location. Further service diversions may be required and the brook in this area would need to be managed.

If the two structures could be built adjacent one would be built directly in line with the slide path. After the installation of the former the second structure would have to be driven to the slide path when required using SPMTs. The full installation operations could be conducted during one visit of the specialist installation contractor.



LTM11200-9.1

Client
Project
Subject

SAP Nr.
Doc. Nr.
Ref. mark.sadler

Page 1/1
Date 11/8/2016
Rev. 00

Crane configuration:

Make: *Liebherr*
Type: *LTM11200-9.1*
Selected chart: *T3Y*

Boomlength: *46.4*
BoomType: *50-100-100*
JibLength: *0.5*
JibAngle: *0*
Adaptor: *2.2*
Carrier: *13.0x13.0*
Counterweight: *202*

Upper rotation: *-405.261*
Lift height: *0*

Lift radius: *30*
Lift capacity: *87*

Elevation

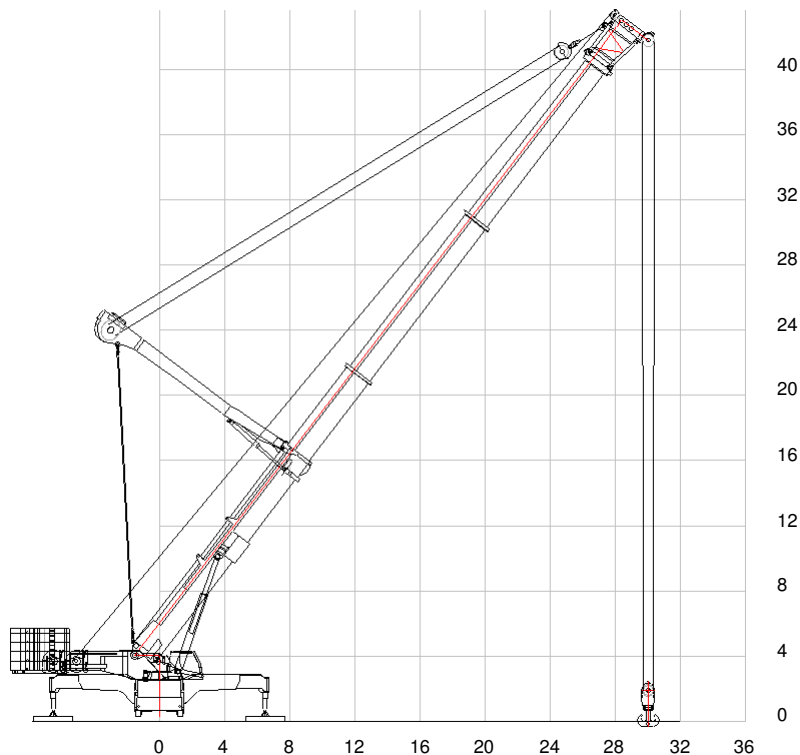

Load configuration:

Title: *Lift*
Load name: *Item-1*
:
Load: *70*
Hook block: *9.5*
Auxiliary: *0*

Rigging: *2*

Total: *81.5*
Percentage[%]: *93.7*

Plan view

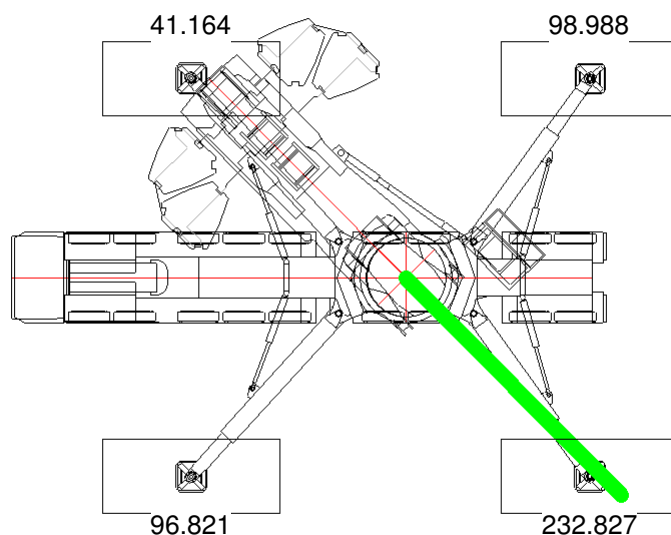

Ground bearing pressures:

Mat height: *0.29*
Mat length: *5.8*
Mat width: *2.4*

Max. GBP under mats: *17.0*



LR1750

Client
Project
Subject

SAP Nr.
Doc. Nr.
Ref. mark.sadler

Page 1/1
Date 11/8/2016
Rev. 00

Crane configuration:

Make: *Liebherr*
Type: *LR1750*
Selected chart: *SDB*

Boomlength: *63*
Carrier: *8.8m*
CenterCwt: *95*
Counterweight: *220*
SL-Cwt: *400*
SL-Radius: *20*
SL-Type: *Tray*

Upper rotation: *-158.508*
Lift height: *36.535*

Lift radius: *38*
Lift capacity: *230*

Elevation

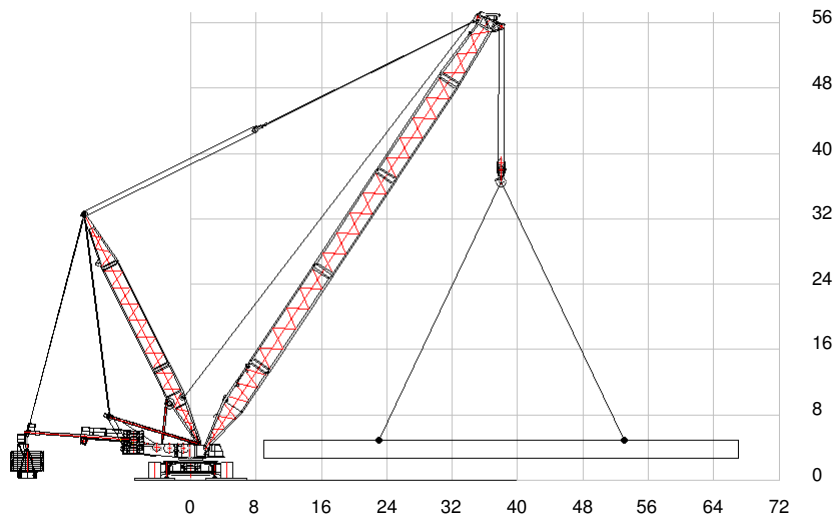

Load configuration:

Title: *Lift*
Load name: *Item-1*
:
Load: *200*
Hook block: *16*
Auxiliary: *0*

Rigging: *0*

Total: *216*
Percentage[%]: *93.9*

Plan view

Ground bearing pressures:

Mat height: *0.2*
Mat length: *1*
Mat width: *5*

Max. GBP under mats: *18.5*

WARNING:
Outriggers and Fixed Jib (SDWVB) charts available on request

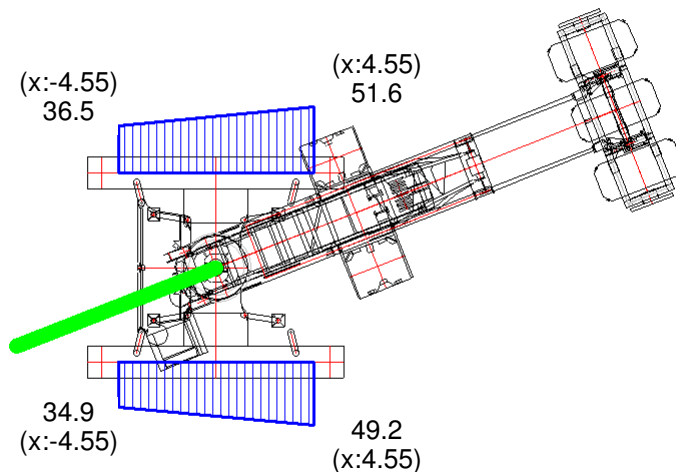



LR1600-2

Client
Project
Subject

SAP Nr.
Doc. Nr.
Ref. mark.sadler

Page 1/2
Date 11/10/2016
Rev. 00

Crane configuration:

Make: *Liebherr*
Type: *LR1600-2*
Selected chart: *SDB*

Boomlength: *60*
Carrier: *8.7x8.4*
CenterCwt: *65*
Counterweight: *150*
SL-Cwt: *350*
SL-Radius: *18*
SL-Type: *Tray*

Upper rotation: *0*
Lift height: *34.849*

Lift radius: *34*
Lift capacity: *226*

Elevation

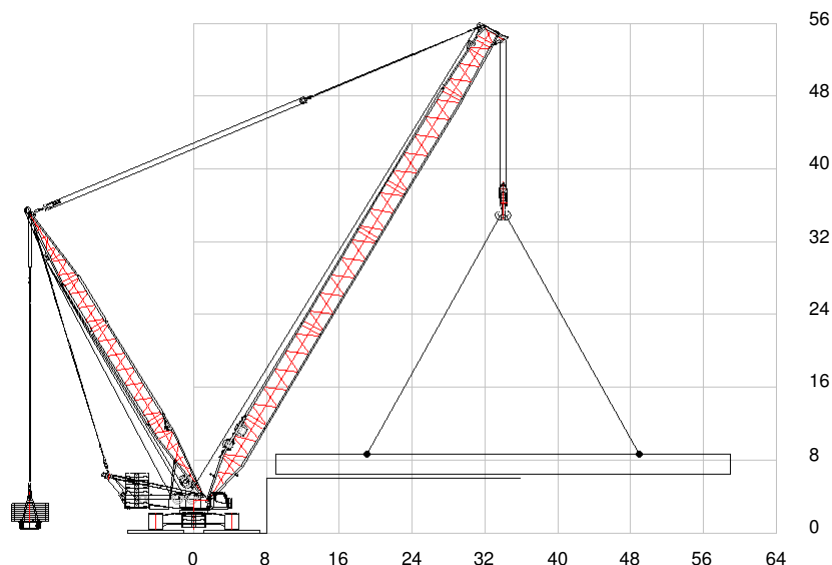

Load configuration:

Title: *Lift*
Load name: *Item-1*
:
Load: *200*
Hook block: *16*
Auxiliary: *0*

Rigging: *5*

Total: *221*
Percentage[%]: *97.8*

Plan view

(Mats omitted for clarity)

Ground bearing pressures:

Mat height: *0.305*
Mat length: *1.219*
Mat width: *6.096*

Max. GBP under mats: *17.4*

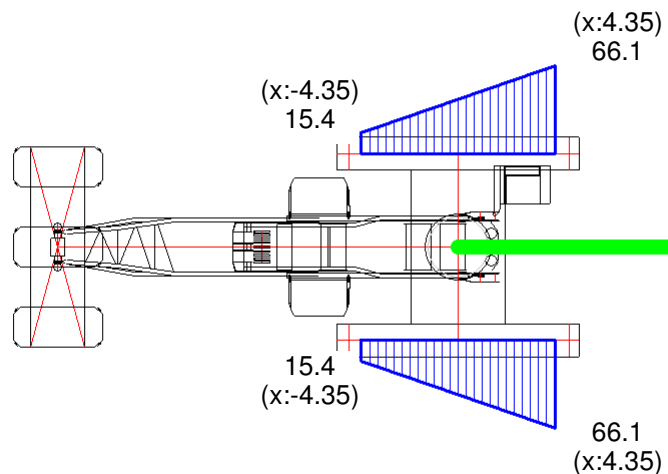



LR1750

Client
Project
Subject

SAP Nr.
Doc. Nr.
Ref. mark.sadler

Page 2/2
Date 11/10/2016
Rev. 00

Crane configuration:

Make: *Liebherr*
Type: *LR1750*
Selected chart: *SDB*

Boomlength: *56*
Carrier: *8.8m*
CenterCwt: *95*
Counterweight: *220*
SL-Cwt: *400*
SL-Radius: *20*
SL-Type: *Tray*

Upper rotation: *0*
Lift height: *35.49*

Lift radius: *34*
Lift capacity: *266*

Elevation

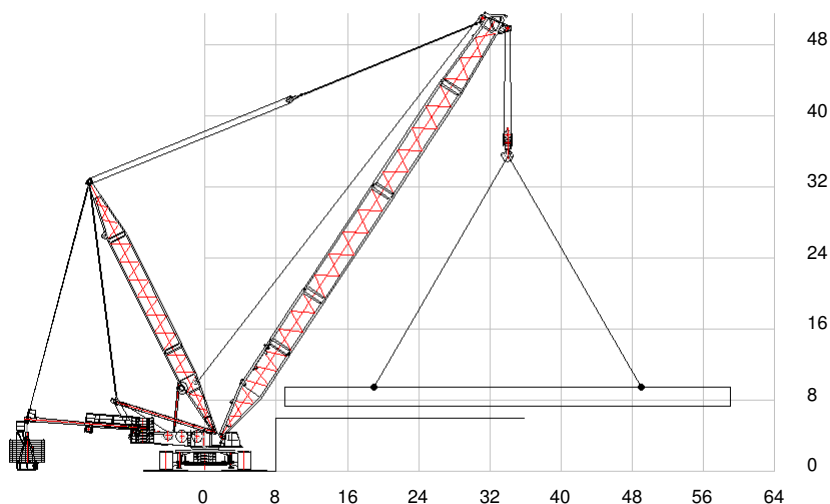

Load configuration:

Title: *Lift*
Load name: *Item-1*
:
Load: *200*
Hook block: *16*
Auxiliary: *0*

Rigging: *5*

Total: *221*
Percentage[%]: *83.1*

Plan view

(Mats omitted for clarity)

Ground bearing pressures:

Mat height: *0.2*
Mat length: *1*
Mat width: *5*

Max. GBP under mats: *30.6*

WARNING:
Outriggers and Fixed Jib (SDWVB) charts available on request

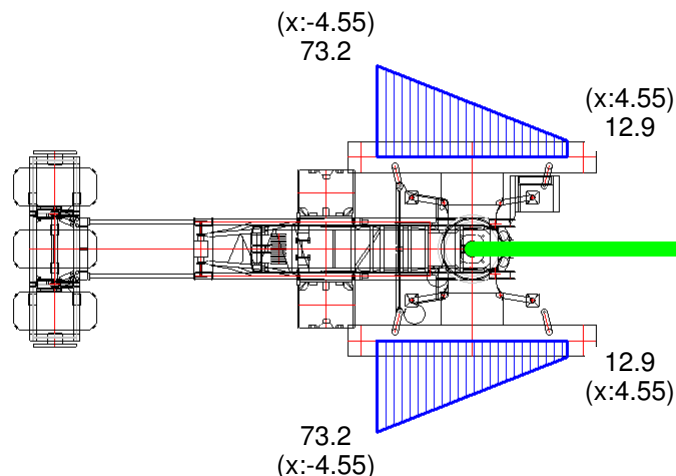



LTM1750-9.1

Client
Project
Subject

SAP Nr.
Doc. Nr.
Ref. mark.sadler

Page 1/1
Date 11/10/2016
Rev. 00

Crane configuration:

Make: *Liebherr*
Type: *LTM1750-9.1*
Selected chart: *TY35*

Boomlength: *32.7*
BoomType: *0+46+92+*
Carrier: *12x12m*
Counterweight: *204*
Lines: *22*

Upper rotation: *0*
Lift height: *13*
Number of parts: *22*

Lift radius: *9*
Lift capacity: *215.8*

Load configuration:

Title: *Lift*
Load name: *Item-1*
:
Load: *200*
Hook block: *5.35*
Auxiliary: *0*

Rigging: *4*

Total: *209.35*
Percentage[%]: *97*

Ground bearing pressures:

Mat height: *0.23*
Mat length: *4.5*
Mat width: *2.4*

Max. GBP under mats: *16.0*

CONSIDER THE RADIUS OF THE SUPERFLIFT OR Y-GUY WHEN PLANNING A LIFT!

Two-block distance is has been estimated due to lack of information.

Elevation

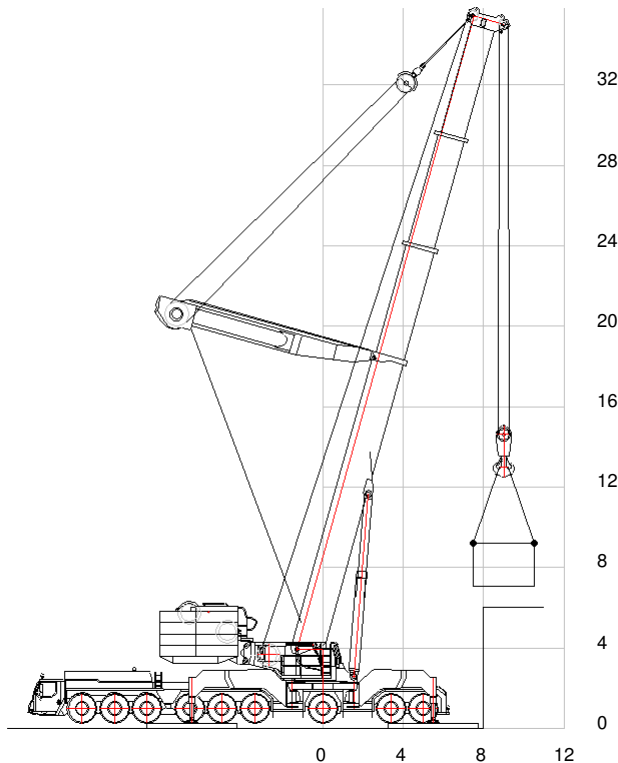

Plan view

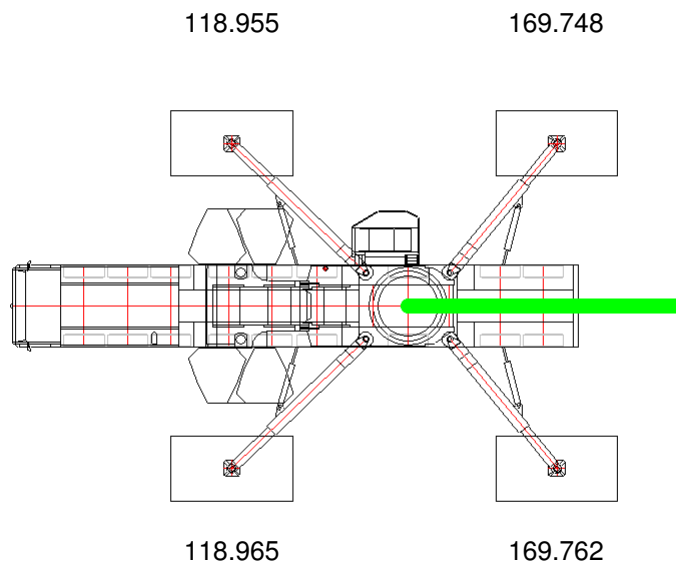

Appendix I

MEETING MINUTES – NWR/HE/WSP PB

Appendix I-1

MEETING MINUTES – NWR/HE/WSP PB

MEETING NOTES



Job Title	A1 Birtley to Coal House
Project Number	70015226
Date	18 October 2016
Time	13.30
Venue	Network Rail - Stephenson House, York
Subject	Allerdene Railway Bridge
Client	Highways England
Present	<ul style="list-style-type: none"> ██████████ – Network Rail ██████████ – Network Rail ██████████ – Network Rail ██████████ – Network Rail ██████████ – Highways England – PM ██████████ – Highways England – PTS Structures ██████████ – Costain ██████████ – WSP Parson Brinkerhoff – PM ██████████ – WSP Parsons Brinkerhoff – Structures ██████████ – WSP Parsons Brinkerhoff – Structures ██████████ – WSP Parsons Brinkerhoff – OLE
Apologies	None
Distribution	As above plus ██████████

Address line 1
 Address line 2
 Address line 3
 Address line 4
 Tel: +0 (0) 0000 000 000
 Fax: +0 (0) 0000 000 000
 www.wsp-pb.com

MATTERS ARISING

ACTION

1.0 INTRODUCTIONS

1.1 Introductions were made

2.0 PROJECT OVERVIEW

2.1 ██████ gave a brief overview of the scheme proposals and the potential impacts on Allerdene Railway Bridge. All scheme options will provide 4 lanes of traffic in each direction between Junction 65 (Birtley) to Junction 66 (Eighton Lodge) and Junction 66 (Eighton Lodge) to Junction 67 (Coal House). Provision for 3 lanes of traffic in each direction will be provided through Junction 66 (Eighton Lodge) and Junction 67 (Coal House).

2.2 There are currently 2 options under consideration, and both are identical with the exception of the proposed location of the replacement Allerdene Railway Bridge. Option 1 includes for an on line replacement of the existing structure. The replacement structure will be significantly wider than the existing structure and the finished road level will also have to be raised to achieve minimum clearance requirements for Network Rail. Option 1 would also require a temporary structure to be constructed either to the north of the existing bridge to ensure that 2 lanes of traffic can be maintained in each direction at peak periods during construction. It is likely that the demolition of the existing Allerdene Railway Bridge will be on construction programme critical path. Option 1 is now referred to as Option 1b.

MATTERS ARISING	ACTION
<p>2.3 This option is also likely to heavily impact on the Gas Transfer ~Station to the North West of Allerdene Railway bridge as this site is still operational. Northern Gas Networks are currently generating cost estimates</p>	
<p>2.4 Option 2 includes a new bridge to be constructed to the south of the existing Allerdene Bridge. This structure will also be significantly wider than the existing bridge, however as this structure can be constructed remotely from the existing road thereby potentially reducing temporary works which would likely result in a reduced construction programme. It is also likely that the demolition of the existing bridge will not be on the critical path of the construction programme. Option 2 is now referred to as Option 1a.</p>	
<p>2.5 Option 3 which proposed a new alignment for the A1 to the south of the existing alignment between Junction 66 (Eighton Lodge) and the west of Junction 67 (Coal House) including a remodelled Junction 67 to the south of the existing junction has now been discarded following the completion of the Options Identification stage. Following the completion of detailed cost estimates for each option in Stage 1, Option 3 was deemed unaffordable.</p>	
<p>2.6 ■ noted that Highways England's current aspiration is to commence construction before March 2020. The anticipated construction period for Option 1a is 44 months and for Option 1b is 49 months. This excludes "advanced works" to undertake stats diversions as required.</p>	
<p>2.7 At present, following the work undertaken to date, including the recent Public Exhibition, It is likely that Option 1a will be the preferred option.</p>	
<p>3.0 PROPOSED STRUCTURE</p>	
<p>3.1 WSP PB have submitted 2 initial reports to Network Rail outlining the preferred option for the proposed replacement structure and proposals for updating the OLE equipment. ■ outlined the key principles of the proposed structure.</p>	
<p>3.2 The above led to a discussion around the constraints associated with the new bridge and the OLE equipment which can be summarised as follows:</p> <ul style="list-style-type: none"> • The minimum clearance from the rail to the contact wire should be 4.7m. • It is approximately 1.0m from the contact wire to the top of the sagged catenary wire. • It is approximately 2.0m from the contact wire to the top of the masts. • Network Rail would ideally like an additional 1m clearance from the top of the catenary wire or top of masts based on the location of the bridge) to the underside of the bridge. • The distance between the masts cannot be more than 50m. • WSP PB proposal currently assumes that masts will extend between the beams of the proposed structure. Network Rail would ideally like an additional 1m clearance from the top of the mast to the underside of the bridge resulting in a total of approximately 6.7m clearance from the rail to the underside of the bridge. WSP PB are to reassess the proposal to take account of this aspiration. • It was accepted by Network Rail that if Option 1a is to progress that the OLE under the existing bridge may remain in a temporary state until the existing bridge is demolished (potentially 2 years). • Network Rail noted that acceptable gradients for change in contact wire should be provided even during the temporary state. • Network Rail would prefer if non-standard equipment was not adopted on the scheme, as this would result in increased maintenance training and costs for Network Rail operatives. • It should be physically impossible for any plant or equipment to fail/collapse and land within 3m of any Network Rail Plant or apparatus. • It is up to HE to risk assess and mitigate the proposed construction methods for the 	WSP PB

MATTERS ARISING	ACTION
<p>new bridge.</p> <ul style="list-style-type: none"> The Bridge AIP should acknowledge that signal sighting has been considered. Bonding needs to be considered to transfer the induced current in the deck back in to the rails. It should be noted that the railway lines are split into sections. The end of each section creates a short circuit with locates the train on the track. 	WSP PB
<p>3.3 WSP PB are to review the current proposals based on the constraints listed above. A review of the highways alignment will be undertaken to determine the maximum finished road level that could be achieved over the railway. It was noted that the highway alignment has to tie in to Kingsway Viaduct which will be remaining in the proposed scheme. An assessment of the positioning of OLE masts will be undertaken to determine if a clearance of 6.7m can be avoided. It will also be investigated if the proposed bridge decks for the new structure can be separated to allow interim OLE masts can be positioned. It was acknowledge the this would require moving the westbound carriageway channel further to the south.</p>	
<p>3.4 ■ stated that a submission for Land Requirements to undertake the work could be submitted now to obtain property clearance. This will highlight at an early stage if Network Rail have any proposals for the land required and would highlight any clashes at an early stage. The submission for property clearance should include a GA and a summary of the land requirements with a clear indication of what the land is need for (ie access, future maintenance or permanent works etc). WSP PB will prepare this submission on behalf of HE. A response to the land requirements submission will take between 10 and 12 weeks.</p>	
<p>4.0 DEMOLITION OF EXISTING STRUCTURE/POSSESSIONS</p>	
<p>4.1 Possessions on the East Coast Mainline will be problematic and are likely to be in line with the Rules of the Route (ROR). The ROR for the King Edward VII bridge which carries the East Coast Mainline over the River Tyne are currently as follows:</p> <ul style="list-style-type: none"> Sunday 00.01 to 07.45 Christmas Eve approximately 23.00 to Boxing Day approximately 06.00. There is the potential to negotiate an extension to these periods. Extensions will need to be supported by a robust Business Case. If works are planned in excess of 5 years in advance, it is possible to modify the train timetables to incorporate the works. 	■
<p>5.0 ANY OTHER BUSINESS</p>	
<p>5.1 ■ noted that A-One+ have a possession planned for maintenance works to Allerdene Bridge in the near future. The possession is being organised by Noel Beverage of A-One+. AM noted that it might be possible to utilise this possession to undertake topographical survey within Network Rail's boundary if required. ■ to determine if survey data is required and NW to organise access with HE OD.</p>	

NEXT MEETING

To be advised.

Appendix J

RESPONSE TO AONE + ALLERDENE BRIDGE QUERIES

Appendix J-1

MEETING MINUTES – NWR/HE/WSP PB

MEMO

TO: Nicola Wilkes – Highways England
FROM: WSPPB A1B2CH Design Team
SUBJECT: A1B2CH ALLERDENE BRIDGE – OFFLINE VS HYBRID OPTION
DATE: 30 March 2017

Below are details of the formal response to the Area 14 MAC Allerdene bridge queries raised during/after the A1B2CH progress meeting dated 17/03/17.

Formal Comments received (via email) from the Area 14 MAC/WSPPB Response

Risk

The proposed scheme has a very high risk rating due to the large scale of grouting up of mine workings and large earthworks required at the beginning of the scheme, these are the two activities which would have a high risk of delays due to unforeseen extra work and weather influences, Delays mean changes to programme, compensation events and missed milestone dates further down the programme (crane lifts within booked possessions), hence the outturn costs will most likely end up way above the initial projected costs.

WSPPB Response: We note the concerns regarding grouting, however the risk/complexities associated with demolition of the existing bridge and the interface with NWR appears to have been misjudged.

The issues with open mines and grouting are foreseen risk within the area and have been accounted for within the risk register. The proposal for part of the new Allerdene bridge being constructed online (Hybrid Option) would not mitigate the risk associated with grouting as one of the decks would still be required to be constructed offline for which grouting shall be required.

6.75m clearance

This is a very high clearance which I can only presume is for network rail to position OLE stanchions under the bridge to avoid the cables having to be suspended from the bridge deck. One of the design features which I can't understand is the 800mm clearance between decks however, this could be utilised in another way to HE's advantage. The OLE stanchion could be positioned centrally between the deck and the top of the column could fit between the decks, then a stanchion placed directly at the side of each deck. The deck clearance could then be lowered to the point that the stanchion is still below the deck surface. This would allow a reduction of approx 1m in clearance, consequently reduce the embankment height and abutment height saving large amounts of construction time and substantial cost savings.

WSPPB Response: The decks need to be separated as a single deck would be too long to sustain the thermal movements. The separate decks also allows for the spans to be staggered to minimise the clearance/span over the railway infrastructure to ensure they remain within the limits of an integral bridge form.

An 800mm gap was provided to provide sufficient working room to cast the parapet plinth. This was based on discussion with the support Contractor during the development of the Allerdene bridge replacement options. The feasibility of a cover slab between the two decks can be reviewed at detailed design.

The 6.7m clearance was stipulated by NWR to accommodate the OLE without the need to suspend from the structure and to future proof the line for future developments in train technology. At this stage the HE has advised that we provide a solution that satisfies this clearance criterion.

Critical path

It was mentioned that the demolition of the old bridge would be removed from the critical path by building twin decks first. Thereby opening up the 8 lanes. This is only an issue of all the works to the whole scheme. Highway from Birtley to Coalhouse roundabout, and all the bridges (Coalhouse interchange, North Dene, Longbank, Eighton Lodge interchange) widening works are to be completed in the same time frame, otherwise it is irrelevant. There will be 8 lanes at Allerdene railway but restrictions 2 plus 2 everywhere else, negating any benefits at Allerdene for the additional substantial costs.

WSPPB Response: The issue/concern is not related to the provision of sufficient running lanes (2+2) during the works. The proposal is to de-risk the complexities and construction issues associated with an online option that requires demolition and removal of the existing bridge prior to a new structure being installed.

Further complexities associated with retrofit works to raise the substructure and impact on the form of structure (as discussed below) are also mitigated.

Demolition works

It is preferable to have the lifting points for the crane as close as possible to the object to be lifted. By moving the new decks 15m away this decreases the lift capacity of the crane and means a larger crane will be needed possibly with a ballast cradle.

WSPPB Response: We have liaised with the support Contractor and confirmed that the distance between the new and existing decks satisfies both the build ability of the new bridge and removal of the existing.

Grouting works

The old bridge had the mine workings grouted up, this would probably have extended 10m to 15m around the immediate footprint of the bridge by moving the bridge to 15m from the existing bridge you are removing any benefit the old works would be able to give and again increasing the costs

WSPPB Response: We note that the current footprint of Allerdene bridge and the approaches have been strengthened by previous grouting works. However even with a Hybrid option, grouting would be required at the new offline bridge location and beyond.

It is anticipated this will extend into the area between the existing and new deck footprint and therefore the expected cost/saving between a hybrid and offline option would be circa 20-25%. However any saving would need to be offset against the increase programme and cost associated with the online bridge construction and the risk/complexities associated with bringing the existing bridge demolition onto the critical path.

The table below details potential issues associated with some of the proposal raised by the Area 14 MAC during the progress meeting dated 17/03/17.

<u>Issues</u>	<u>Comments</u>
<p>Demolition of the existing bridge</p>	<p>The demolition of the existing bridge is complicated by the following:</p> <ul style="list-style-type: none"> • Structural deck is substandard and has been retrospectively strengthened at the half joints • Spans over the ECM will require multiple weekend possessions to remove or a full blockade (over 2 years to book). Possession works are high risk and adverse weather or other factors (limited working window) can significantly reduce time available to safely cut and remove beams on a piece meal basis • The crash deck (will contain any loose debris, minimise site clearance over the track) will not negate the requirement for possessions when lifting beams out over the ECM.
<p>Re-use of the existing sub structure element – piers and abutments</p>	<ul style="list-style-type: none"> • Having reviewed the archive drawings, the bridge is on a 45deg skew, therefore reuse of the existing substructure would rule out integral forms of construction. • This results in a structural form that shall require major maintenance every 25-30 years over its 120 service life to replace bearings. The operation to replace bearing shall also require jacking points to be incorporated in the design (circa 48No. locations – 12 at each end support + 12 at each intermediate piers) • The WLC associated with a 3 span structure (with

	<p>bearings/leaking joints) will be significantly greater than an integral form of construction (no bearings – no replacement cost).</p> <ul style="list-style-type: none"> • Reduced maintenance liabilities is a key design requirement by the HE PTS and is something we are trying to incorporate via weathering steel girders (no painting) integral bridge deck (no bearings). • The reuse of the existing sub structure will be further complicated by the level difference. The current structure has a 4.8m clearance. We need to provide a 6.7m clearance. Therefore the existing substructure elements will have to be modified retrospectively to provide the clearance required. It is not as straight forward as simple removing the deck and installing new beams on existing elements.
<p>Online bridge deck – with infilling of the side spans and modifications to the piers</p>	<ul style="list-style-type: none"> • To simplify the structural form the side spans could be in filled (introduces another construction operation/cost) and the existing piers can be taken down and reconstructed on a new footprint thereby allowing for an integral bridge form to be considered. <p>The construction of new end supports at a new location would negate assumed benefits associated with reusing existing substructure elements. Any new supports would require piled foundations due to ground conditions and therefore savings associated with piling works would not be realised with a on line option.</p> <ul style="list-style-type: none"> • The cost and programme implications with a new hybrid bridge construction would be greater in comparison to the 2No. bridge decks being constructed offline that is not dependant on the demolition of the existing bridge.
<p>Level difference accommodation</p>	<ul style="list-style-type: none"> • Construction of the new online deck would require works to raise the level of the approaches leading up to and beyond the bridge (circa 4m taking account of the clearance + construction depth). <p>We note we are doing this for the offline bridge alignment, however this would need to done for 2No. discrete alignments for the hybrid option thereby</p>

	impacting the complexity/cost with the earthwork/retaining structure requirements.
--	--

To date WSPPB have substantially value engineered the complexity and cost of the original offline proposal inherited at the commencement of the scheme. This has been achieved by the following:

- Retention of the coal house junction – avoid reconstruction of Kingsway Viaduct and the associated roundabout structures.
- Retention of Smithy Lane bridge
- Reduction in the land take in comparison to the previous off line Allerdene bridge option
- Reduction in the structural footprint of the replacement Allerdene bridge

The current preferred offline option would significantly de-risk and simplify the construction of a complex bridge over the East Coast Mainline. In the long term it would also allow for a more robust structure with limited future maintenance liabilities to be handed over to the Area 14 MAC. Based on the above WSPPB consider the offline replacement of Allerdene bridge to be the preferred solution.

Appendix K

STANTON CROSS BRIDGE DATA SHEET

Appendix K-1

STANTON CROSS BRIDGE DATA SHEET

Stanton Cross Development – New Bridge Design

GALLIFORD TRY

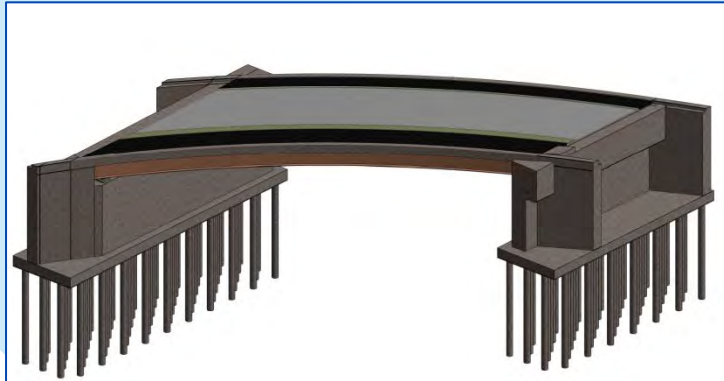

LOCATION

Wellingborough, England, UK

CLIENT

Galliford Try –D&B contract

STATUS

2016

WSP | PB DELIVERY TEAM

Bridge Infrastructure Team – Leeds Based

COSTS & FEES

Design - £80k

Construction - £5m

OVERVIEW

A new housing development, Stanton Cross planned to the east of Wellingborough required a road over the Midland Main Line (road over rail bridge) as one of the main access routes to the site. Based on the preliminary feasibility studies (previously completed by WSP|PB) a single span curved composite bridge was considered for the detailed design. The bridge required reinforced soil wing walls on three sides for the earthworks and was designed to meet Northamptonshire County Council and Network Rail requirements.

WSP|PB were commissioned to design the bridge and associated wingwalls and also provide technical support during the construction phase.

SERVICES

- Feasibility studies
- Detailed design of curved steel concrete composite bridge – management of the technical approval and CAT3 check process
- Development of Level 2 BIM models to support the construction stage and clash detection

OUTCOME

WSP | PB produced designs for the curved steel bridge which met the requirements of various stakeholders. A 4.5m setback was chosen to mitigate the need for derailment design and further setback from the track was incorporated to provide space for future expansion of the line.

WSP|PB multidisciplinary in house design capabilities ensured the design progressed and, where necessary, modified efficiently in order to meet the tight programme and commencement of the construction phase.

The use of FE analysis (LUSAS, Midas) enables a structurally efficient bridge design to be progress for construction. The structure was designed considering multiple construction stages which allowed for efficient erection of steel work and casting of parapets, reducing the amount of disruptive possessions required.

Reinforced soil wing walls were designed to provide a cost effective solution for the scheme and reduce maintenance requirements over the whole life of the structure. The use of access galleries to inspect bearings also reduces the need for Network Rail possessions and working at height for future maintenance based inspections.

Stanton Cross Development – New Bridge Design

GALLIFORD TRY

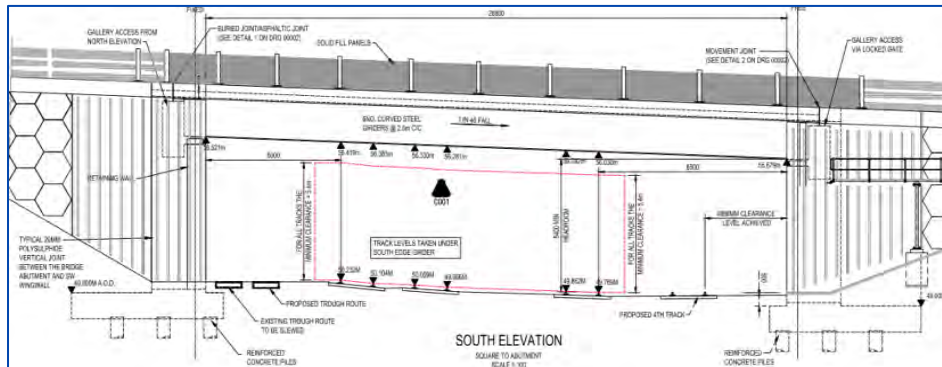

FEATURES / ADDED VALUE

WSP|PBs in house BIM capabilities enabled 3-D models to be developed and utilised for both visualisation (planning application support) and construction stage assessments.

In house knowledge and understanding of NWR working/structural requirements ensured approval were sought and requirements were incorporated without significant impact of the design programme.

WSP|PB in depth knowledge of UK technical approval requirements (in accordance with BD2/12) for new bridge/highway structure designs, ensured the technical approval requirements of NCC was accommodated with no complication/disruption to the design programme.

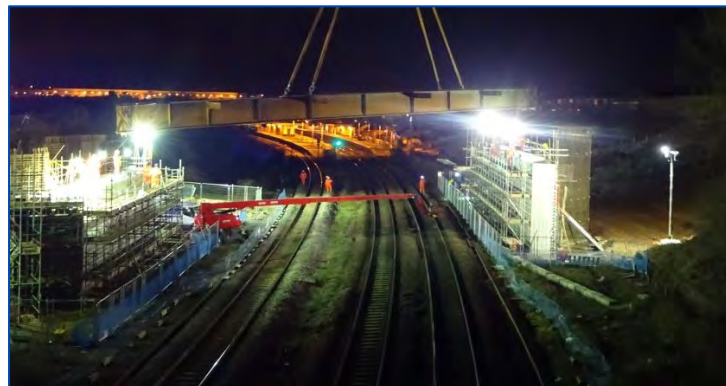

WSP|PB CONTACTS

Hitan Mistry, Structures Team Leader

Email: Hitan.Mistry@wspgroup.com

Rakesh Mehta, Structures Design Lead

Email: Rakesh.Mehta@wspgroup.com

Appendix L

DESIGNERS RISK ASSESSMENT – ALLERDENE BRIDGE

Appendix L-1

**DESIGNERS RISK ASSESSMENT – ALLERDENE
BRIDGE**

Guidance notes (see guidance notes page for more details)

Design risk management should be an integral part of the overall design development and designers should think of it in terms of considering constructability, maintainability, etc. Designers only need to document their consideration of risks in this simple risk register format. There is no requirement for quantitative design risk assessments to be carried out/documentated and these should be avoided.

* Risks should be considered in a logical sequence relating to the location/operational environment, constructability/installability, operability (normal/emergency), maintainability (inc. routine cleaning, replacement, etc.), and alteration/decommissioning/dismantling/demolition, and should be categorised against those headings.

CIRIA guidance documents C662, C663, C611, C607, etc. provide a useful checklist and detailed guidance on the identification of risks to be considered during design and how those risks might be addressed - see detailed guidance notes for more details

⁵ Significant residual risks are those which are unusual, not obvious, difficult to manage, or where critical design assumptions apply. The documentation by designers of residual risks that cover well-known and understood hazards should be avoided

Ref	Risk Category* (and Phase where appropriate, e.g., location/environment, construction, operation, maintenance, alteration/demolition)	Work Element/Location (where appropriate)	Hazard or Risk Issue Identified	Risk Management Owner	Design ERIC Action Required (e.g., hazard elimination/risk mitigation action, information to be provided to others)	Significant Temporary Works Requirements/Management Arrangements and/or any Special Erection/Installation Sequences or Requirements	Design Action Status/Final Resolution Notes (e.g., traceability of ERIC action, communication of significant residual risk, critical design criteria, etc.)	Significant Residual Risk ⁵ (Y/N)	Date Logged/Reviewed	Raised By
001	Construction	Allerdene Rail Bridge	Working at height	Contractor	Use of GRP/GRC planks will minimise the working at height. Consideration to be given to lifting of girders in pairs with the planks in place between girders. The formwork for the string course and worker protection barriers will also be in place before the lifting of the edge beam. This procedure will further reduce working at height and provide a safe working platform.	Large assembly room required on site to deliver girders and set in pairs prior to lift. Crane and associated pad required.	Note on drawing highlight risk associated with works at height - particularly during the beam lift.	Y	20/09/2016	Rakesh Mehta
002	Construction	Allerdene Rail Bridge	Personnel and Plant Encroaching the Railway	Contractor	All works to be designed so that they can be constructed within safe working zones or during railway possessions as agreed with NR.	Temporary work minimised by use of lifting/launching of steel beams	Works information to state requirement for some possession working. Contractor team to be made aware of NR working environment risks (PTS training) . Note to be placed on drawings	Y	20/09/2016	Rakesh Mehta/Hitan Mistry
003	Construction/Operation/Maintenance	Allerdene Rail Bridge	Damage to services, electrocution	Contractor	Service requirements to be confirmed prior to constructions. Details to be included in appendix 1/16 of the works information. All services to be located above the soffit to simplify access without disruption to the railway.	None	Appropriate note/reference to be put on drawings relating to the proposed service ducts provided and their location. Appropriate note/reference to be put on drawing for the location of existing services.	N	20/09/2016	Rakesh Mehta
004	Construction	Allerdene Rail Bridge	Long beam will require strict delivery arrangements and transportation to site will be problematic, leading to potential road side incidents.	Designer	Detailed design to ensure fabricated girders are manageable not excessively long etc) to ensure they can be delivered to site with minimal logistical risks.	Access to construction area to be designed as part of TTM plan.	Contractors to consider method of delivery and erection. Defined loading and unloading areas to be shown on drawings	N	20/09/2016	Rakesh Mehta
005	Construction	Allerdene Rail Bridge	Heavy lifting - steel beams - risk of unstable load due to lifting points not aligning with centre of gravity	Designer / Contractor	The beams will be lifted in pairs to minimise the risk of instability and high torsion buckling of single beams. Design to consider designated lifting points to limit risk on instability.	Appropriate craneage to be used with a lifting plan. Contractor will need to ensure cranes are adequately sized and positioned.	Heavy lifting risk to be recorded on drawings	Y	20/09/2016	Rakesh Mehta/Hitan Mistry
006	Construction	Allerdene Rail Bridge	Deep excavations for open/pad foundation for abutment construction. Potential risk of collapsing of excavation, entrapment of personnel, overturning of plant and vehicles.	Designer	CFA/ bored piled foundation for abutments eliminates risk of deep excavations	Temporary works minimised		N	20/09/2016	Rakesh Mehta
007	Construction	Allerdene Rail Bridge	Working with concrete - in-situ concrete deck construction require handling of large volumes of concrete. Shuttering requires significant temporary works. Also large reinforcement cages with dangers from impaling and lifting of bars, working at heights etc.	Designer	In-situ concrete works for the bridge deck has been limited by the proposed installation of steel beams which reduces concrete operations on site. The in-situ deck slab would use permanent formwork that eliminates additional site operations associated with the removal of formwork.		Details of steel beams (size/length etc) to be defined on drawings.	N	20/09/2016	Rakesh Mehta
008	Construction	Allerdene Rail Bridge	Site vehicles using public highways to transport excess materials to disposal sites. Mud on roads, airborne contamination during/after transit	Contractor	Identify agreed route where disruption will be minimised and how the site will be accessed by construction traffic during the works.	Wheel washing facility to be used on site to minimise mud tracked onto road network. Tarpaulins and straps to be checked before deliveries leave site.	Contractor to plan all site deliveries and make suppliers aware of these. To be defined in TTM plan.	N	20/09/2016	Rakesh Mehta
009	Construction	Allerdene Rail Bridge	Instability/movement of GRP deck planks, create gaps and risk of tools/materials falling onto the live railway	Contractor	Concreting to be done in a controlled manner, to ensure planks are not dislodged	Contractor to implement a suitable SSOV	Risk to be added to drawings	Y	20/09/2016	Rakesh Mehta/Hitan Mistry
010	Maintenance	Allerdene Rail Bridge	Maintenance of bearings induce risk associated with working at height/Live Railway	Designer	Proposed structure is integral. Therefore the risks associated with maintenance of bearing and expansion joints are eliminated.	-	-	N	20/09/2016	Rakesh Mehta
011	Maintenance	Allerdene Rail Bridge	Painting of structural members induce risk associated with working at height/disruption to railway.	Bridge Owner	Proposed structure comprise weathering steel girders. Therefore the risks associated with maintenance painting operations are eliminated.	-	-	N	20/09/2016	Rakesh Mehta
012	Demolition	Allerdene Rail Bridge	Removal of deck during demolition leading to sudden collapse.	Demolition contractor/ designer	Design to consider demolition sequence. Contractor should demolish superstructure reverse to construction sequence.	-	-	N	20/09/2016	Rakesh Mehta

Appendix M

INDICATIVE CONSTRUCTION SEQUENCE

Appendix M-1

INDICATIVE CONSTRUCTION SEQUENCE

DO NOT SCALE

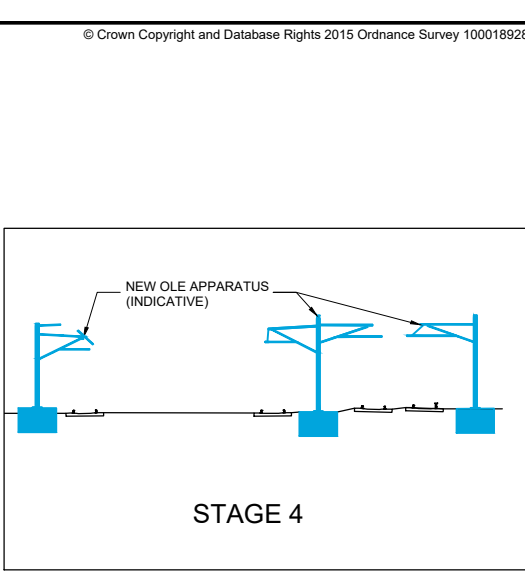
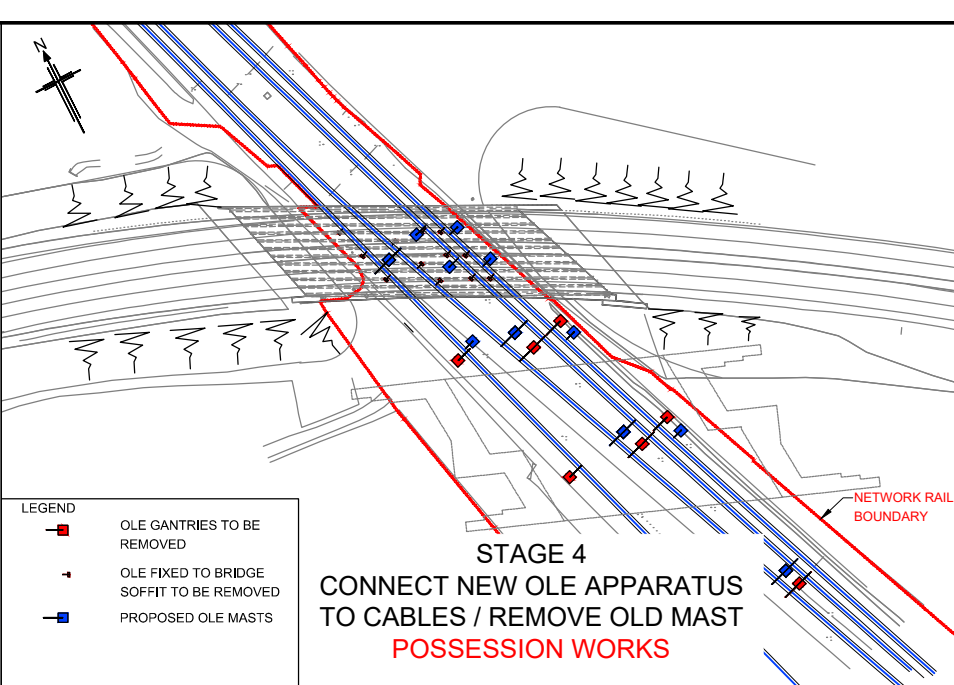
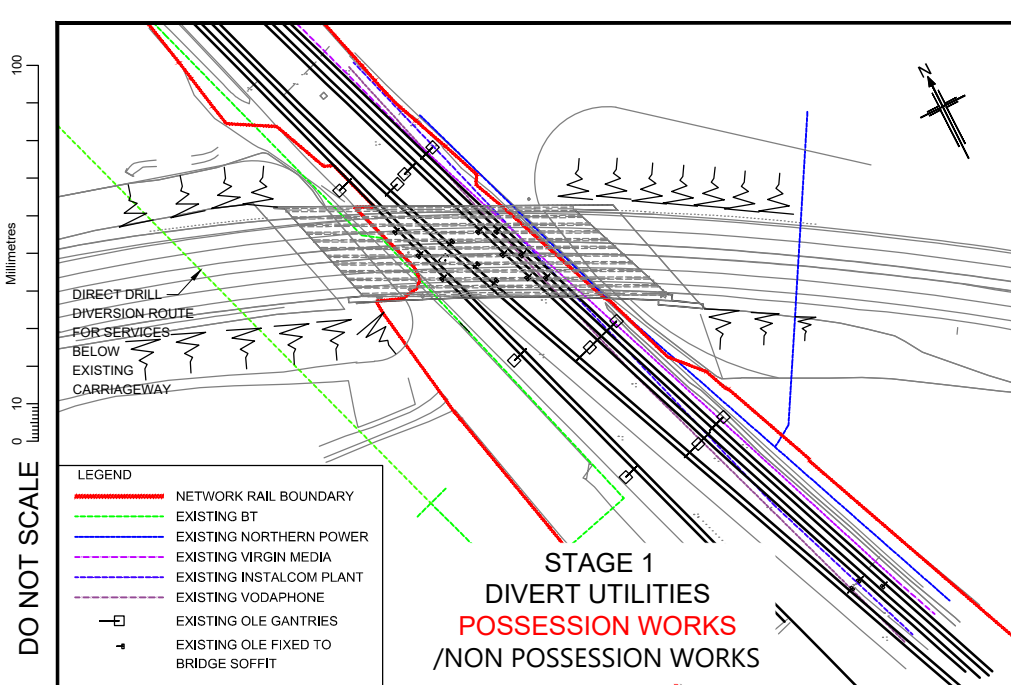

NOTES

- 1) INDICATIVE CONSTRUCTION SEQUENCE FOR THE NEW ALLERDENE BRIDGE CONSTRUCTION IS PROVIDED ON DRG NO. HES51462-WSP-SBR-BCH-DR-S-00010 TO 00013.
- 2) THE INDICATIVE SEQUENCE HAS BEEN DEVELOPED BASED ON COLLABORATION WITH THE SUPPORT CONTRACTOR DURING THE PCF STAGE 2 SCHEME DEVELOPMENT.
- 3) THE FINAL APPOINTED PRINCIPAL CONTRACTOR SHALL BE RESPONSIBLE FOR THE DEVELOPMENT AND IMPLEMENTATION OF THE PROPOSED CONSTRUCTION SEQUENCE.
- 4) DETAILS OF THE VARIOUS CONSTRUCTION STAGES HIGHLIGHTED IN THE INDICATIVE SEQUENCE IS PROVIDED BELOW.

STAGE 1 DIVERT UTILITIES (POSSESSION/NON POSSESSION WORKS): ALL SERVICES IMPACTING THE WORKS SHALL BE IDENTIFIED AND DIVERTED TO ACCOMMODATE THE WORKS. THE CONTRACTOR SHALL BE RESPONSIBLE FOR THE DIVERSION OF ALL SERVICES IMPACTING THE WORK.

STAGE 2 INSTALL NEW OLE BASES (POSSESSION WORKS): FOUNDATION AND BASES FOR THE NEW OLE MAST SHALL BE INSTALLED IN ACCORDANCE WITH THE OLE DESIGN, DETAILS ARE PROVIDED IN THE OLE GRIP 3 REPORT (NO.HES51462-WSP-SBR-BCH-RP-E-1700-043). THE FOUNDATIONS AND BASES SHALL BE DESIGNED IN ACCORDANCE WITH NETWORK RAIL (NR) TAA REQUIREMENTS.

STAGE 3 INSTALL NEW OLE GANTRY MASTS (POSSESSION WORKS): THESE SHALL COMPRISE PROPRIETARY SYSTEMS THAT HAVE BEEN APPROVED BY NR.

STAGE 4 CONNECT NEW OLE APPARATUS TO CABLES/REMOVE OLD MASTS (POSSESSION WORKS): THIS SHALL ENSURE OLE PROVISIONS ARE IN PLACE UPON INSTALLATION OF THE NEW BRIDGE AND DEMOLITION OF THE EXISTING.

STAGE 5 INSTALL ENABLING WORKS FOR THE BRIDGE ABUTMENTS CONSTRUCTION (NON POSSESSION WORKS): ANTICIPATE ENABLING WORKS IN THE FORM OF SHEET PILES SHALL BE REQUIRED TO FACILITATE THE BRIDGE ABUTMENT CONSTRUCTION. THE DESIGN OF THIS SHALL REQUIRE BOTH HE/NR TAA INPUT. IT IS ASSUMED THE SHEET PILES SHALL REMAIN INSITU UPON COMPLETION.

STAGE 6 INSTALL PILES FOR THE BRIDGE ABUTMENTS (NON POSSESSION WORKS): ANTICIPATE TRACK MONITORING SHALL BE REQUIRED DURING THIS STAGE TO ENSURE THE MOVEMENT OF THE TRACK REMAINS WITHIN ACCEPTABLE LIMITS.

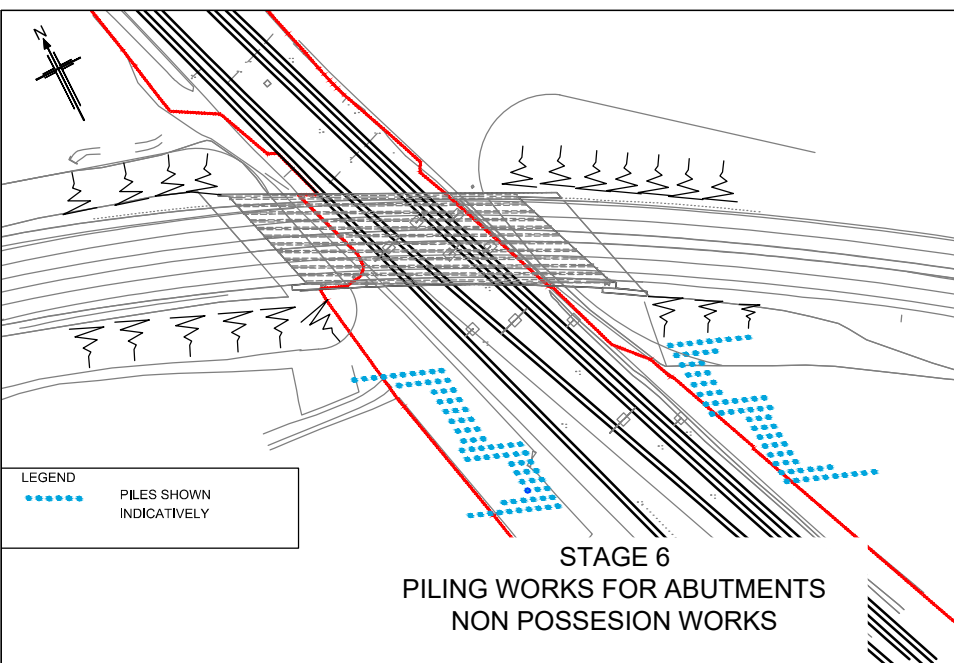
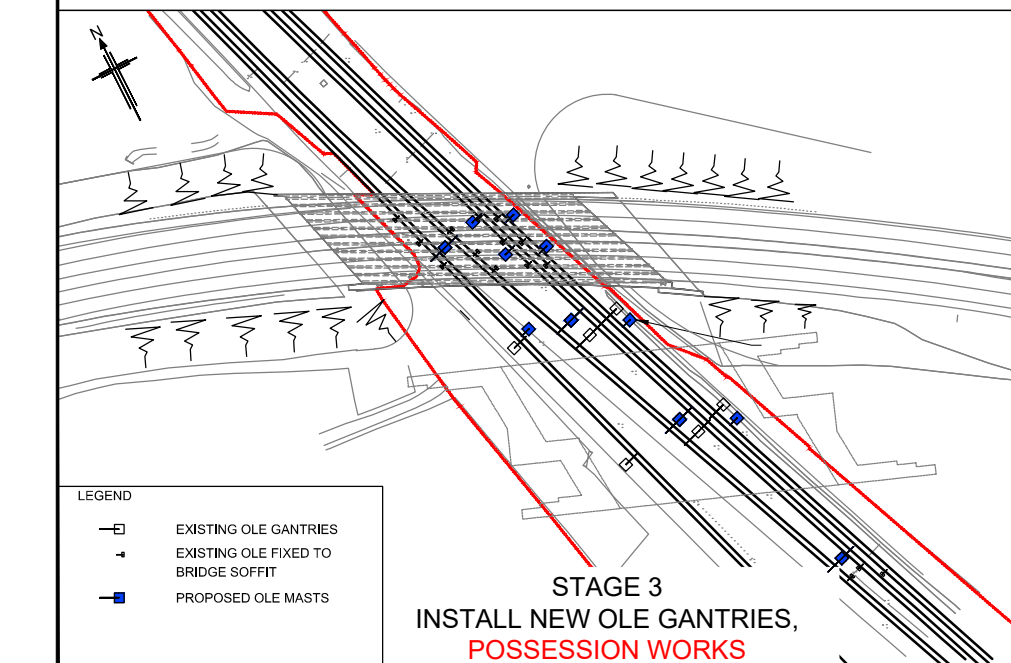
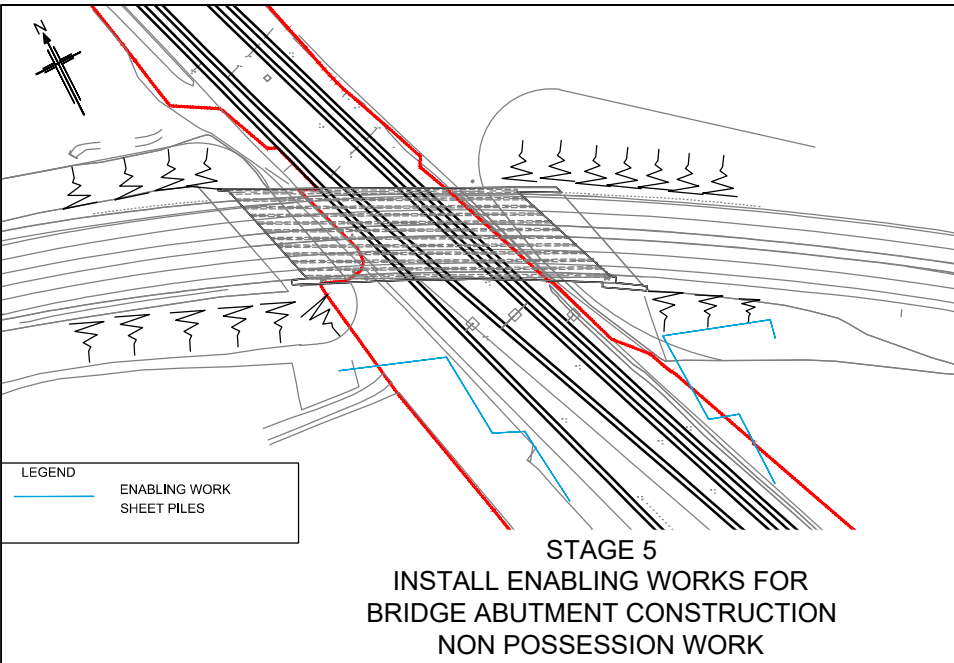
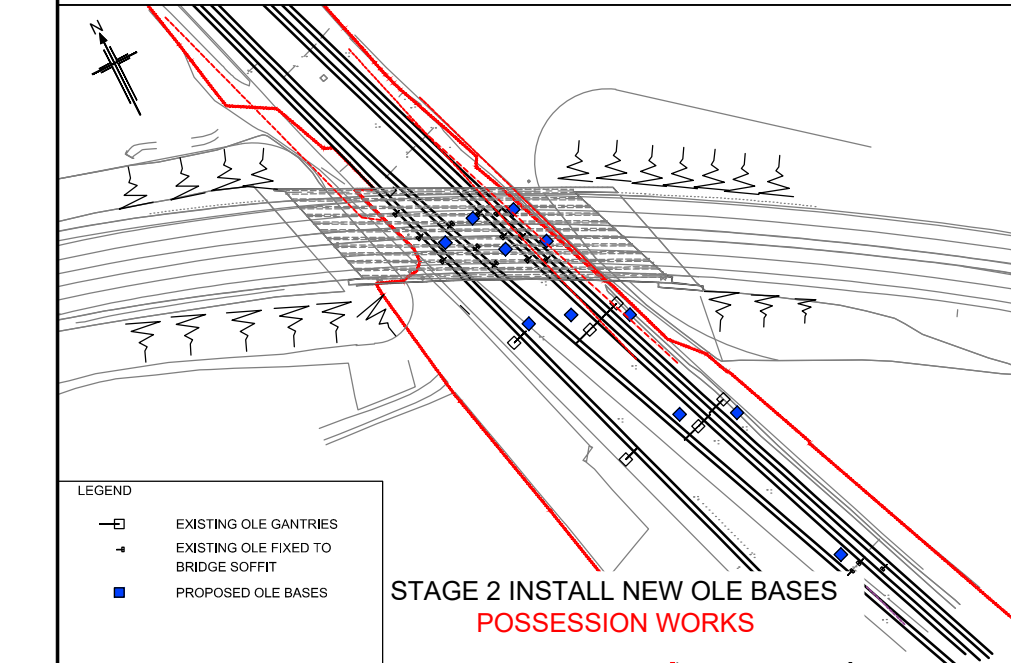

Rev.	Date	Description	By	Chk'd	App'd
P01.1	11/11/16				

WSP Three White Rose Office Park, Millshaw Park Lane, Leeds, LS11 0DL
Tel: +44 (0)113 395 6200

PARSONS BRINCKERHOFF

© WSP UK Ltd www.wsp-pb.com

Client: **Working on behalf of**
highways england

Project Title		A1 BIRTLEY TO COALHOUSE			
Drawing Title		ALLERDENE OFFLINE REPLACEMENT SINGLE SPAN INTEGRAL BRIDGE INDICATIVE CONSTRUCTION SEQUENCE SHEET 1 OF 4			
Scale	Drawn	Checked	Approved	Authorised	
N/A	---	---	---	---	
Original Size	Date	Date	Date	Date	
A1	---	---	---	---	
Drawing Status			Initial Status or WIP		Suitability
					S0
Drawing Number	Project	Originator	Volume	Project Ref. No.	
HE551462	WSP	SBR			
BCH	DR	S	00010	Revision	
				P01.1	

DO NOT SCALE

Millimetres
0 10 100

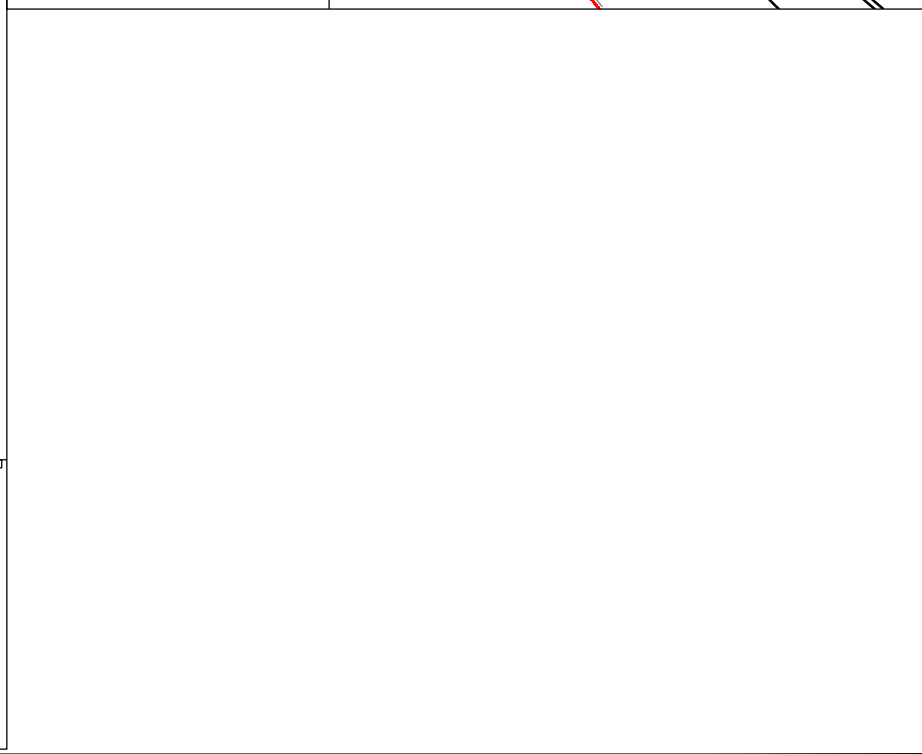
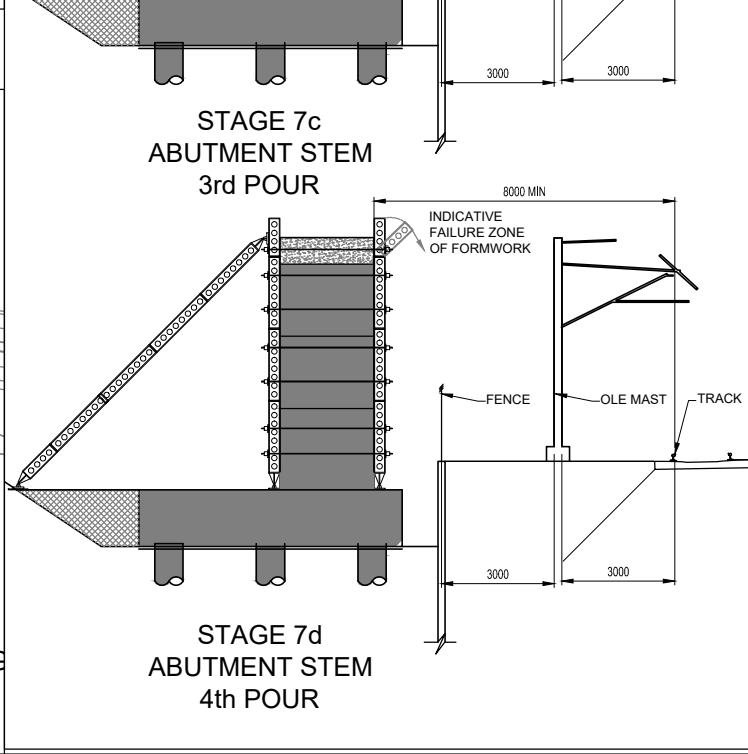
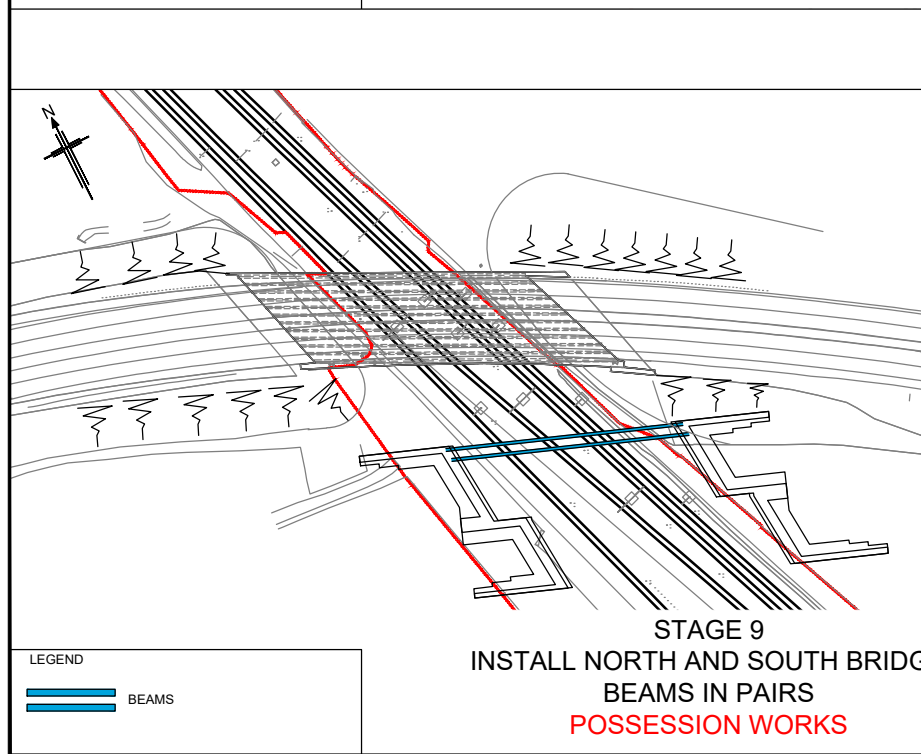
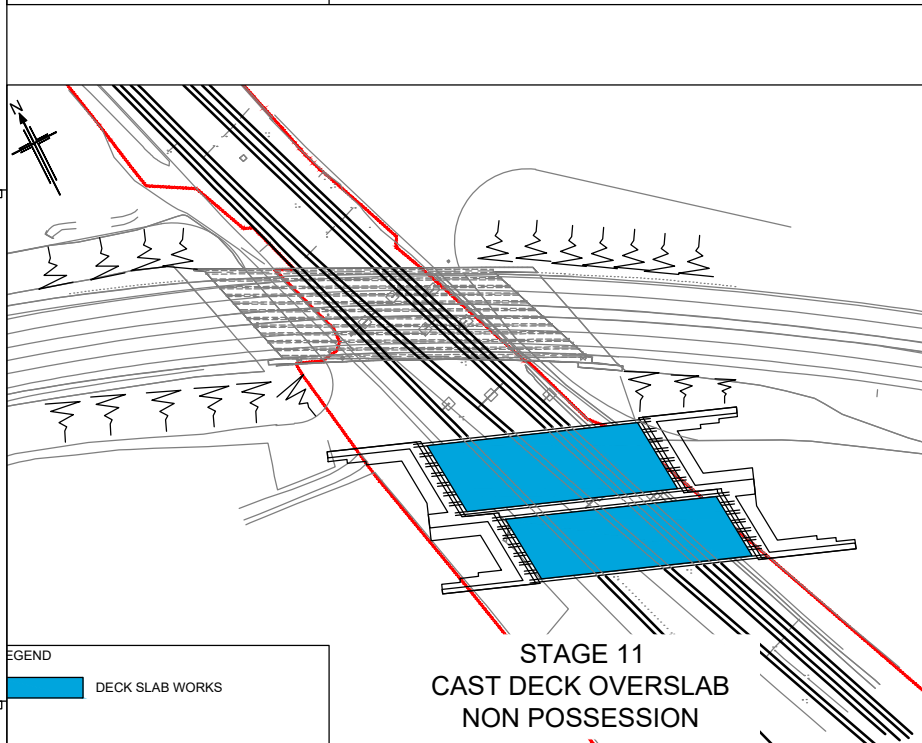
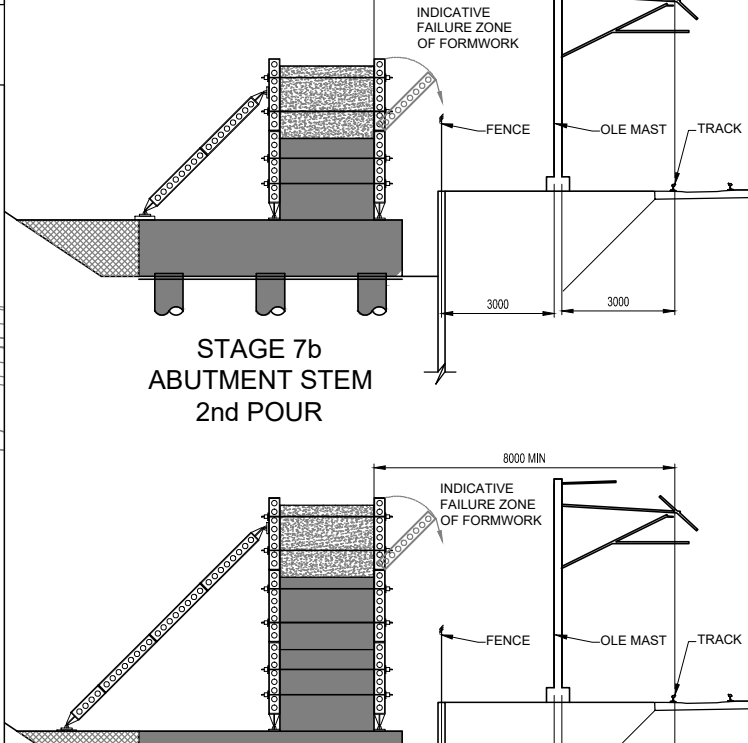
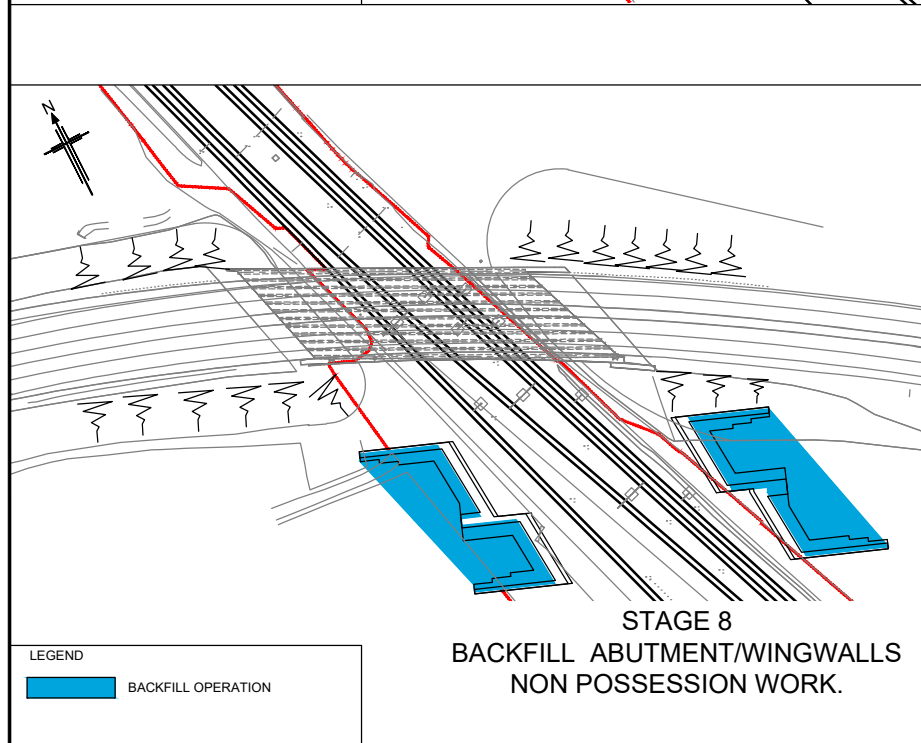
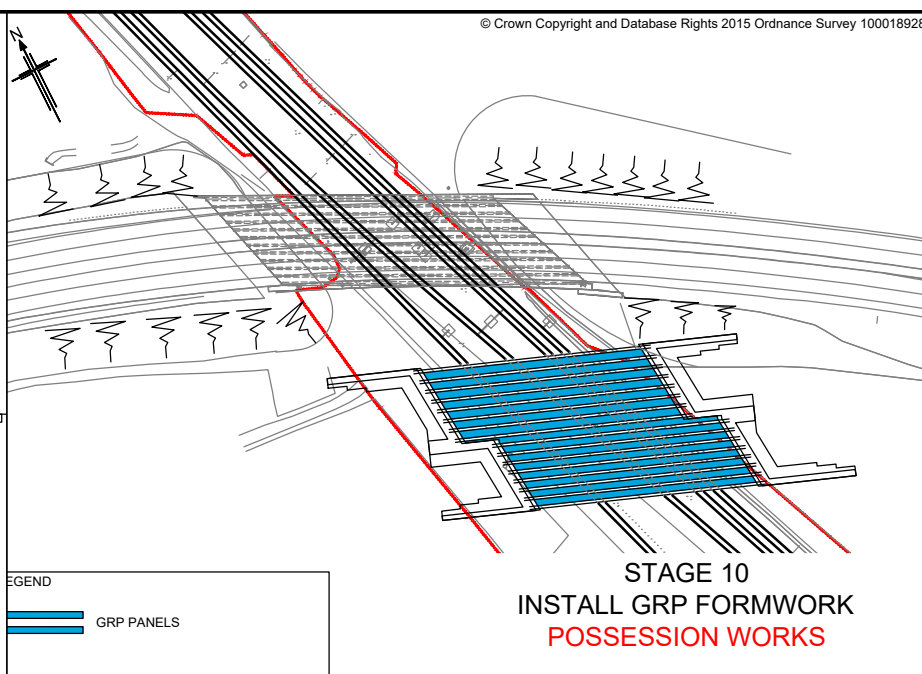
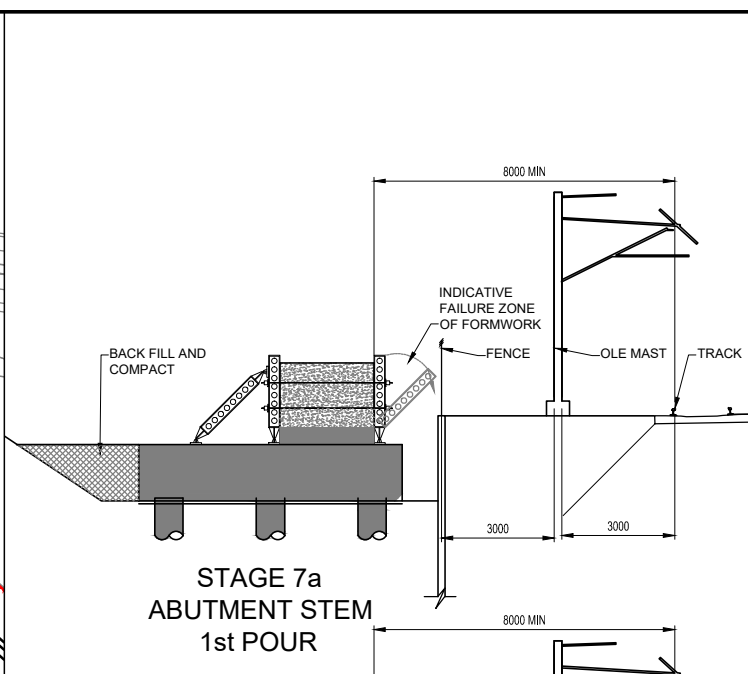
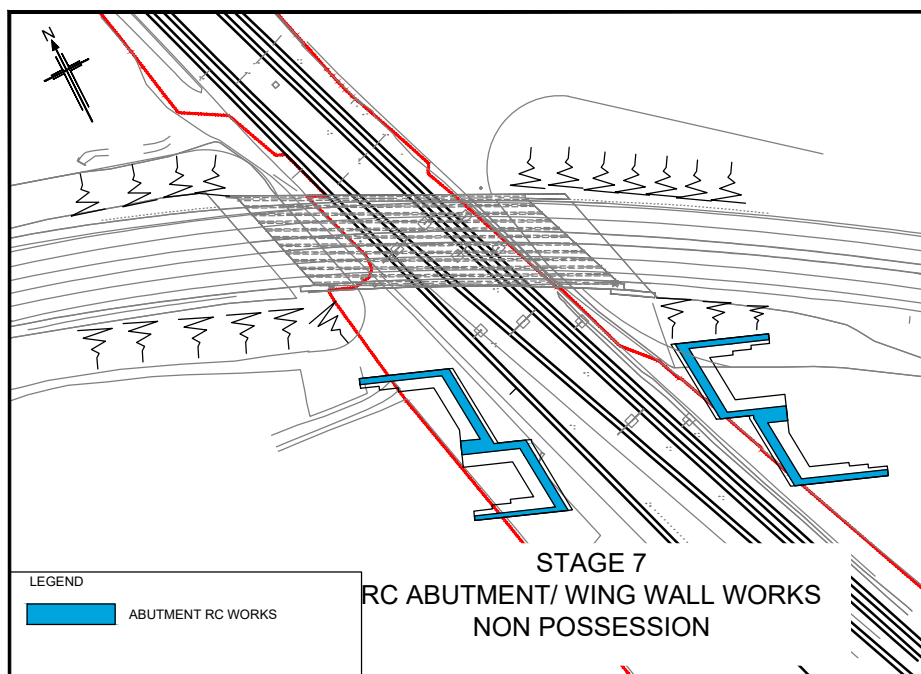

- NOTES
- 1) INDICATIVE CONSTRUCTION SEQUENCE FOR THE NEW ALLERDENE BRIDGE CONSTRUCTION IS PROVIDED ON DRG NO. HES51462-WSP-SBR-BCH-DR-S-00010 TO 00013.
 - 2) THE INDICATIVE SEQUENCE HAS BEEN DEVELOPED BASED ON COLLABORATION WITH THE SUPPORT CONTRACTOR DURING THE PCF STAGE 2 SCHEME DEVELOPMENT
 - 3) THE FINAL APPOINTED PRINCIPAL CONTRACTOR SHALL BE RESPONSIBLE FOR THE DEVELOPMENT AND IMPLEMENTATION OF THE PROPOSED CONSTRUCTION SEQUENCE
 - 4) DETAILS OF THE VARIOUS CONSTRUCTION STAGES HIGHLIGHTED IN THE INDICATIVE SEQUENCE CONT.

STAGE 7 RC ABUTMENT/WINGWALL WORKS (NON POSSESSION WORKS): ABUTMENTS TO BE CAST IN STAGES TO LIMIT RISK OF FORMWORK FALLING WITHIN 3M OF THE NEAREST OLE LINE/RUNNING RAIL

STAGE 8 PART BACKFILL TO ABUTMENT/WINGWALLS (NON POSSESSION WORKS)

STAGE 9 NORTH AND SOUTH BRIDGE BEAMS IN PAIRS (POSSESSION WORKS): TEMPORARY WORKS IN THE FORM OF A CRANE LIFTING PAD SHALL BE REQUIRED. THE POSITION/SIZE OF THE CRANE TO BE CONFIRMED

STAGE 10 INSTALL GRP FORMWORK (POSSESSION WORKS): PERMANENT FORMWORK SHALL PROVIDE A WORKING PLATFORM FROM WHICH WORKS CAN BE UNDERTAKEN OUTSIDE POSSESSION FOR THE CASTING FOR THE RC DECK SLAB

STAGE 11 CAST RC DECK SLAB: DECK TO BE CAST UP TO THE EDGE CANTILEVERS/PARAPET UP STAND (NON POSSESSION WORKS)

Rev.	Date	Description	By	Chk'd	App'd
P01.1	11/11/16				

Three White Rose Office Park,
 Millshaw Park Lane,
 Leeds, LS11 0DL
 Tel: +44 (0)113 395 6200
 © WSP UK Ltd www.wsp-pb.com

Client

 Working on behalf of
**highways
england**

Project Title
A1 BIRTLEY TO COALHOUSE

Drawing Title
**ALLERDENE OFFLINE REPLACEMENT
SINGLE SPAN INTEGRAL BRIDGE
INDICATIVE CONSTRUCTION SEQUENCE
SHEET 2 OF 4**

Scale	Drawn	Checked	Approved	Authorised	
N/A	---	---	---	---	
Original Size	Date	Date	Date	Date	
A1	---	---	---	---	
Drawing Status	Initial Status or WIP				Suitability
					S0
Drawing Number	Project	Originator	Volume	Project Ref. No.	
HE551462	WSP	SBR		Revision	
Location	Type	Role	Number	P01.1	
BCH	DR	S	00011		

DO NOT SCALE

100
0 10
Millimetres

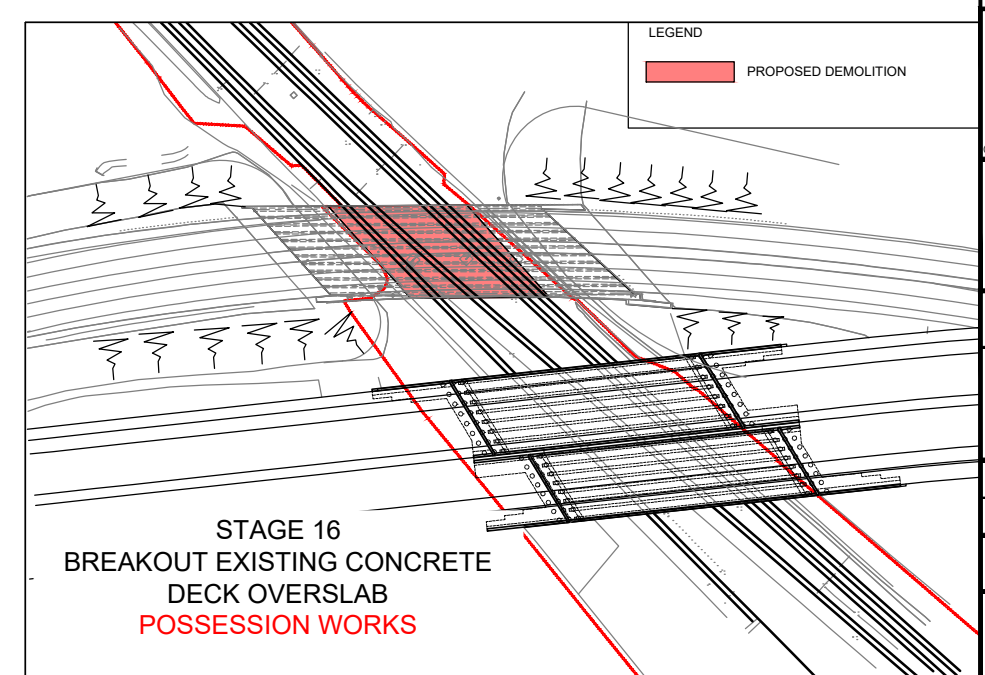
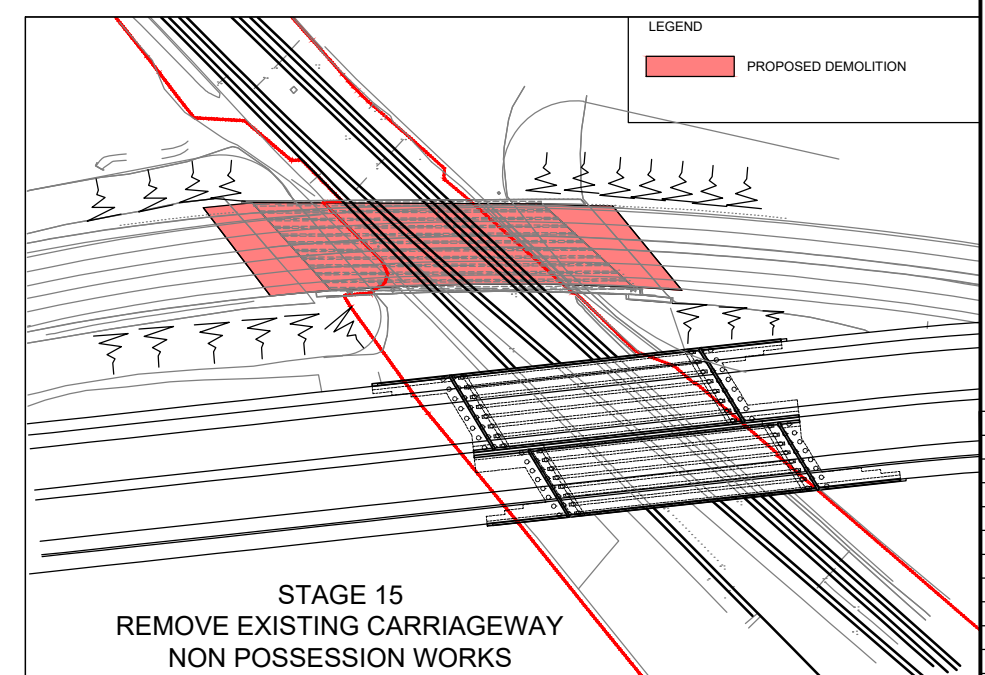
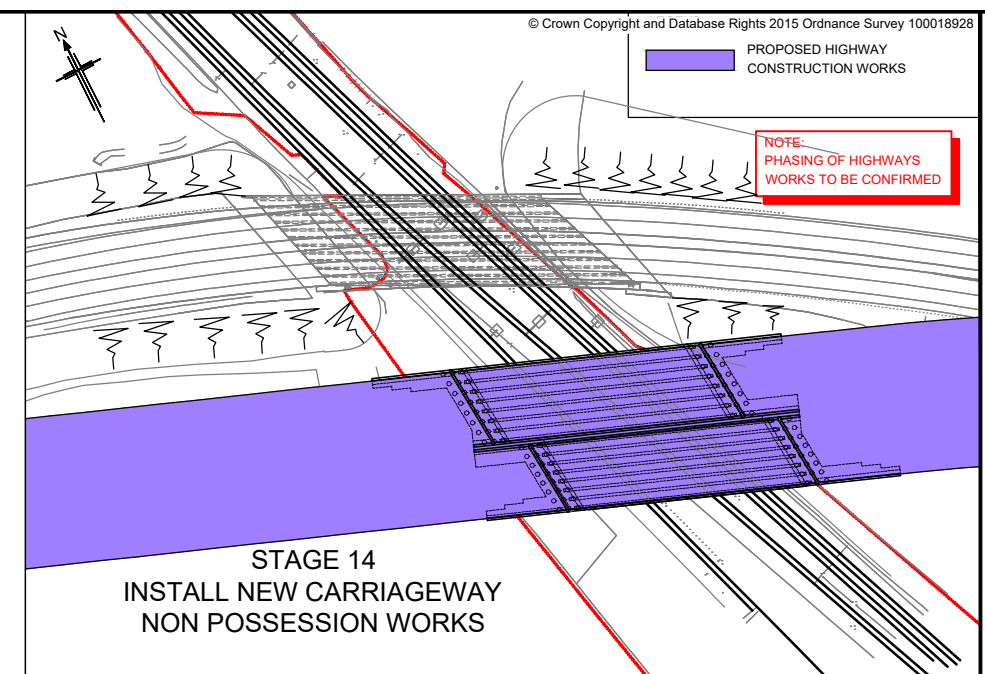
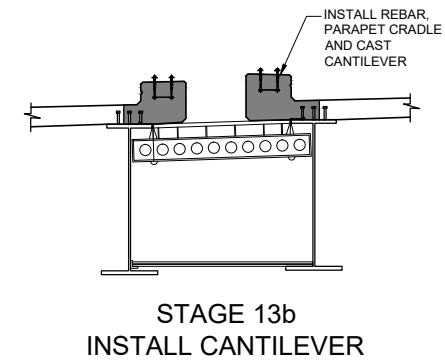
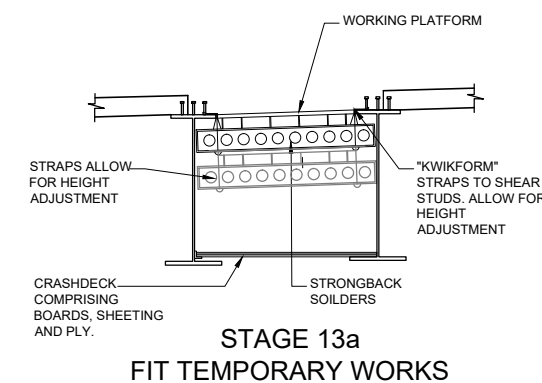
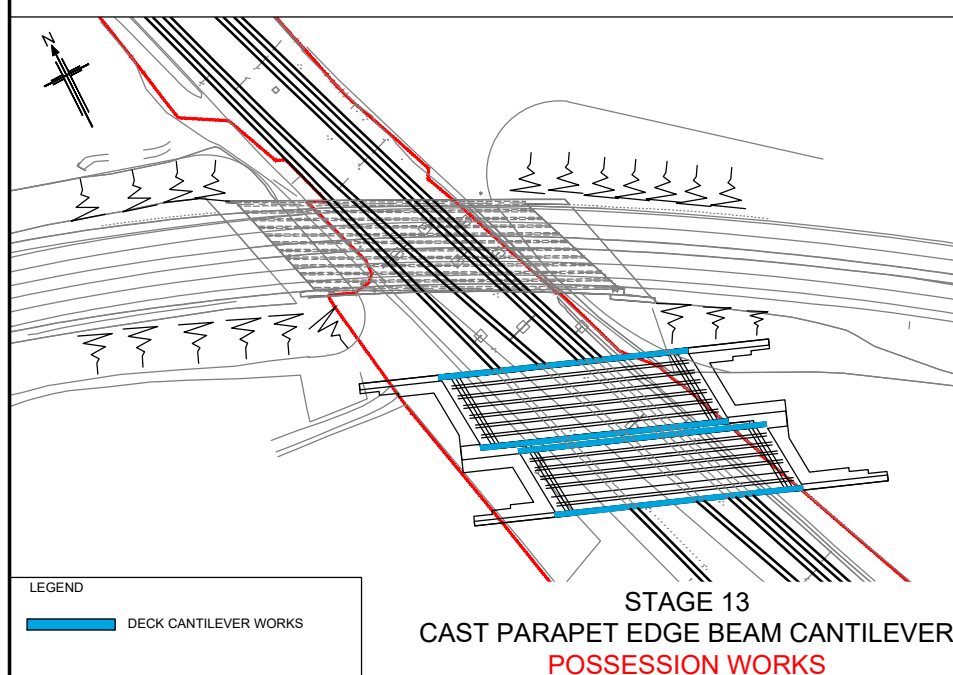
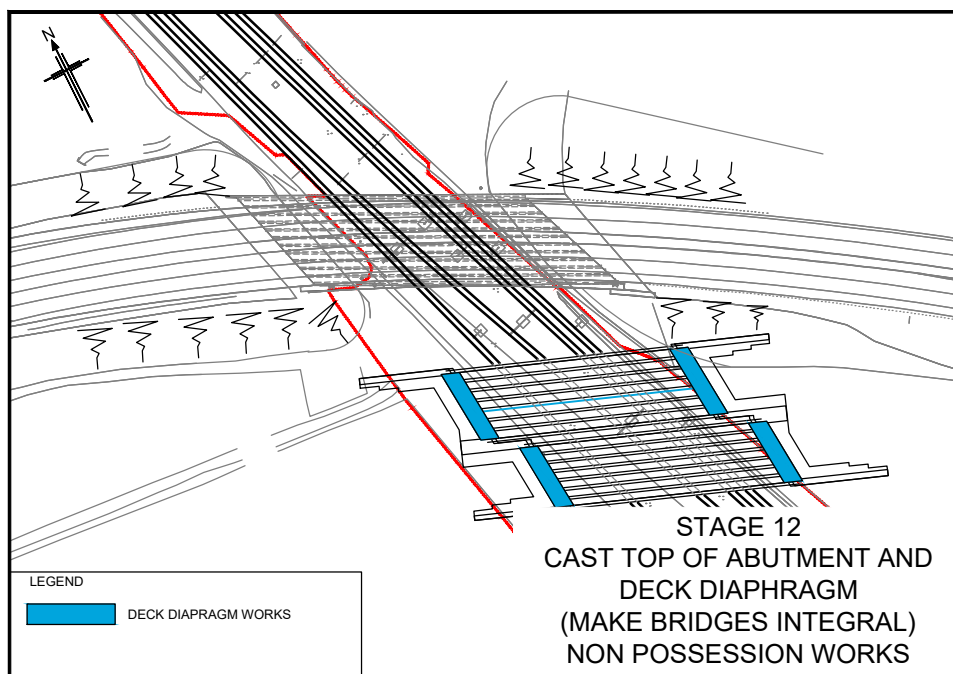

NOTES

- INDICATIVE CONSTRUCTION SEQUENCE FOR THE NEW ALLERDENE BRIDGE CONSTRUCTION IS PROVIDED ON DRG NO. HE551462-WSP-SBR-BCH-DR-S-00010 TO 00013.
- THE INDICATIVE SEQUENCE HAS BEEN DEVELOPED BASED ON COLLABORATION WITH THE SUPPORT CONTRACTOR DURING THE PCF STAGE 2 SCHEME DEVELOPMENT.
- THE FINAL APPOINTED PRINCIPAL CONTRACTOR SHALL BE RESPONSIBLE FOR THE DEVELOPMENT AND IMPLEMENTATION OF THE PROPOSED CONSTRUCTION SEQUENCE.
- DETAILS OF THE VARIOUS CONSTRUCTION STAGES HIGHLIGHTED IN THE INDICATIVE SEQUENCE CONT.

STAGE 12 CAST FOR OF ABUTMENT/DECK DIAPHRAGM, MAKE BRIDGE INTEGRAL (NON POSSESSION WORKS)

STAGE 13 CAST PARAPET UPSTAND/CANTILEVER (POSSESSION/NON POSSESSION WORKS): THE CASTING OF THE INNER CANTILEVERS BETWEEN THE TWO ADJACENT DECKS COULD BE UNDERTAKEN OUTSIDE POSSESSION SHOULD SIMILAR TEMPORARY WORKS BE DEPLOYED AS SHOWN ON THE DRAWING. WORKS TO INSTALL EDGE PARAPETS WOULD ALSO BE UNDERTAKEN AT THIS STAGE

STAGE 14 CARRIAGEWAY WORKS (NON POSSESSION WORKS): INCLUDES WATERPROOFING/SURFACING AND CONSTRUCTION OF VERGES TO THE BRIDGE AND EARTHWORKS AND CARRIAGEWAY WORKS FOR THE APPROACHES TO THE NEW A1 HIGHWAY ALIGNMENT. UPON COMPLETION TRAFFIC ON THE EXISTING A1 ALIGNMENT SHALL BE DIVERTED ONTO THE NEW ALIGNMENT TO FACILITATE THE DEMOLITION OF THE EXISTING BRIDGE.

STAGE 15 REMOVE EXISTING CARRIAGEWAY: FROM THE EXISTING REDUNDANT ALLERDENE BRIDGE DECK

STAGE 16 BREAKOUT THE EXISTING CONCRETE DECK OVERSLAB, CENTRAL SPAN (POSSESSION WORKS): REMOVAL OF THE RC DECK TO THE CENTRAL SPAN SHALL REQUIRE CAREFUL CONSIDERATION TO AVOID DAMAGE TO THE RAIL INFRASTRUCTURE

Rev.	Date	Description	By	Chk'd	App'd
P01.1	11/11/16				

WSP
PARSONS BRINCKERHOFF

Three White Rose Office Park,
Millshaw Park Lane,
Leeds,
LS11 0DL
Tel: +44 (0)113 395 6200

© WSP UK Ltd www.wsp-pb.com

Client
Working on behalf of
highways england

Project Title
A1 BIRTLEY TO COALHOUSE

Drawing Title
ALLERDENE OFFLINE REPLACEMENT
SINGLE SPAN INTEGRAL BRIDGE
INDICATIVE CONSTRUCTION SEQUENCE
SHEET 3 OF 4

Scale	Drawn	Checked	Approved	Authorised
N/A	---	---	---	---
Original Size	Date	Date	Date	Date
A1	---	---	---	---
Drawing Status				Suitability
Initial Status or WIP				S0
Drawing Number	Project	Originator	Volume	Project Ref. No.
HE551462	WSP	SBR		
Location	Type	Role	Number	Revision
BCH	DR	S	00012	P01.1

Appendix N

UPDATED INTEGRAL BRIDGE GAS

Appendix N-1

**INTEGRAL BRIDGE OPTION (A) – GIRDER DEPTH
2.0M**

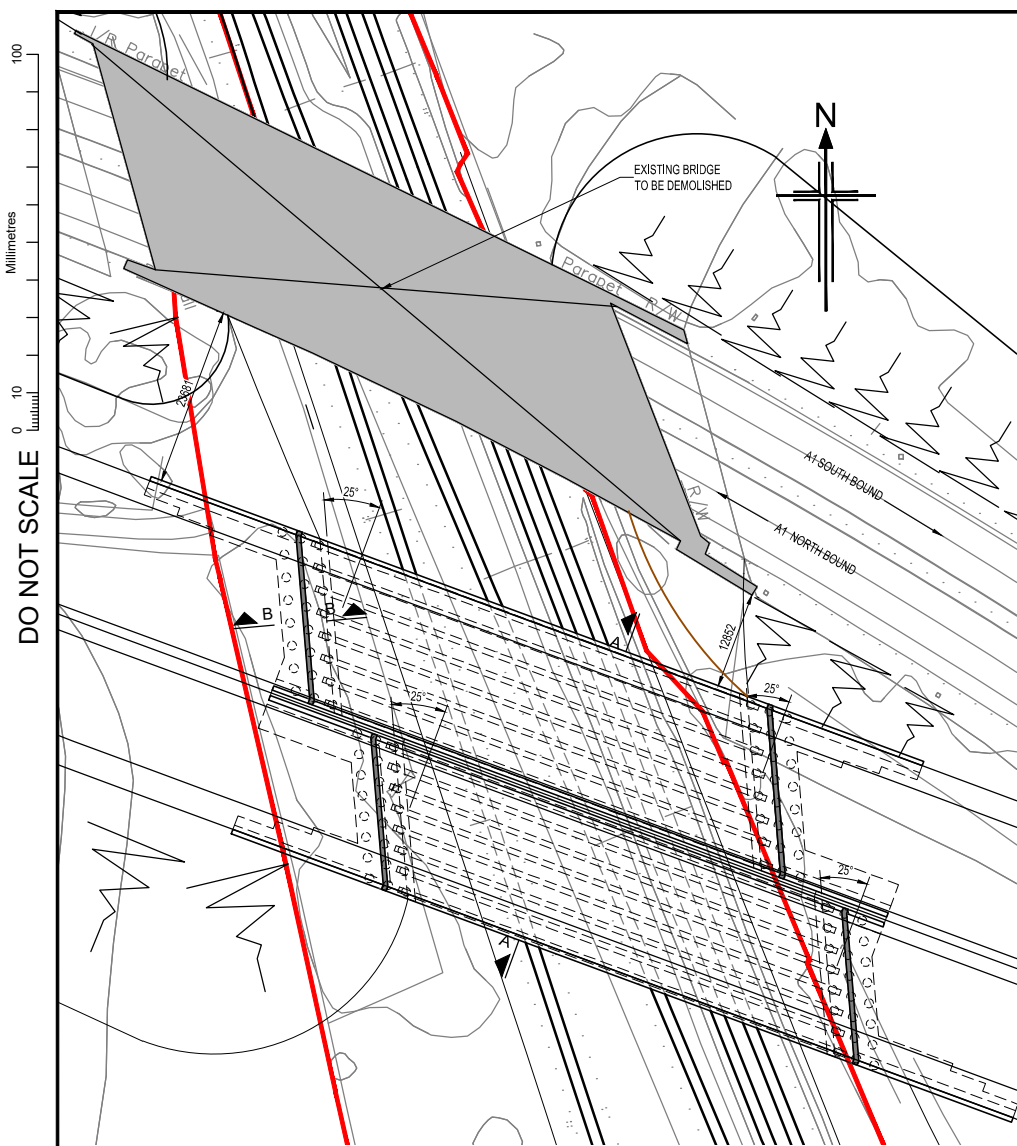

DO NOT SCALE

Millimetres
0 10 100

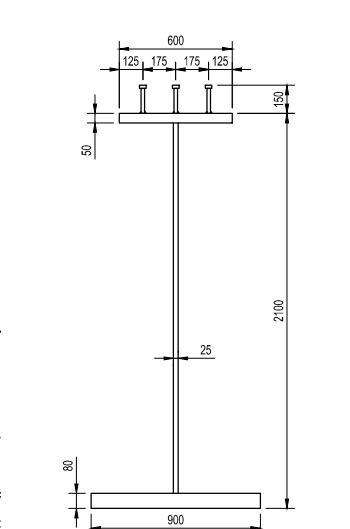

INDICATIVE TYPICAL WEATHERING STEEL GIRDER
SCALE 1:20

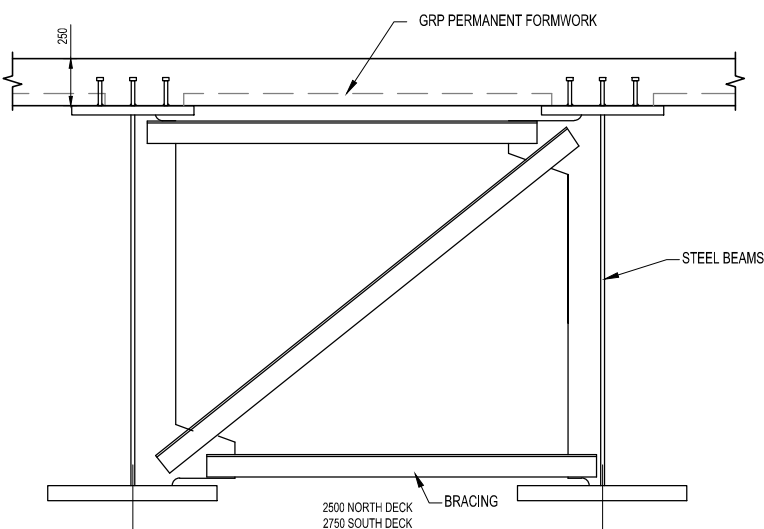

TYPICAL GRP FORMWORK DETAIL ON SOUTH DECK
SCALE 1:20

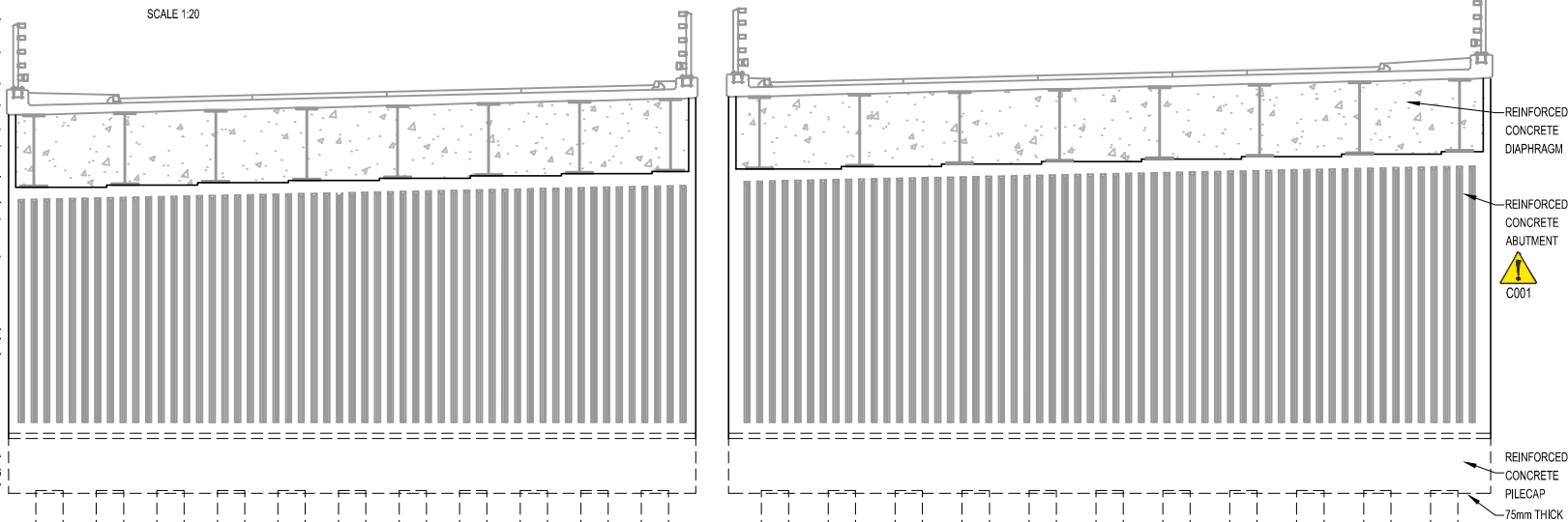

TYPICAL ABUTMENT ELEVATION
SCALE 1:100



KEY PLAN
SCALE 1:5000

- NOTES
- 1) INTEGRAL BRIDGE DETAILS SHOWN ARE BASED ON PRELIMINARY DESIGN CALCULATIONS. DETAILS SHALL BE FINALISED BASED ON COMPLETION OF THE DETAILED DESIGN AND CAT III CHECK
 - 2) ALL DIMENSIONS ARE IN MM UNLESS STATED OTHERWISE
 - 3) ALL LEVELS ARE IN METRES UNLESS STATED OTHERWISE
 - 4) DO NOT SCALE IN CASE OF ANY DOUBTS, OMISSIONS OR ERRORS SEEK CLARIFICATION FROM THE DESIGNER
 - 5) THE BRIDGE SHALL BE CONSTRUCTED IN ACCORDANCE WITH THE RELEVANT DRAWINGS AND SPECIFICATION FOR HIGHWAY WORKS (SHW)
 - 6) THE DESIGN OF ALL OLE WORKS TO BE ACCOMMODATED ARE DETAILED IN THE ALLERDENE RAILWAY BRIDGE OLE GRIP 3 REPORT
 - 7) THE CONTRACTOR SHALL BE RESPONSIBLE FOR THE DIVERSION OF ALL SERVICES IMPACTING THE WORKS. DETAIL OF SERVICES ARE SHOWN ON THE SERVICES INFORMATION DRAWINGS AND APPENDIX 1/16 OF THE SHW
 - 8) THE CONTRACTOR IS RESPONSIBLE FOR ALL TEMPORARY WORKS DESIGN AND INSTALLATION TO FACILITATE THE PERMANENT WORKS
 - 9) THE CONTRACTOR'S ATTENTION IS DRAWN TO THE FOLLOWING MWR CONSTRAINTS TO BE MAINTAINED DURING THE WORKS:
 - THE MINIMUM VERTICAL CLEARANCE FROM THE TOP OF THE RAIL TO THE DECK SOFFIT IS 6.7M
 - THE MINIMUM LATERAL CLEARANCE FROM THE RUNNING LINE TO THE PROVISION OF OLE MASTS IS 3.0M
 - THE MINIMUM SAFETY ZONE TO BE MAINTAINED FROM THE OLE MAST AND THE FENCE LINE (BEHIND WHICH THE BRIDGE SHALL BE CONSTRUCTED) IS 3.0M
 - THE MINIMUM LATERAL CLEARANCE BETWEEN THE RUNNING LINE AND THE FACE OF THE BRIDGE ABUTMENTS IN THE PERMANENT CONDITION IS 4.5M
 - 10) THE CONTRACTOR SHALL REFER TO THE PRE CONSTRUCTION H&S INFORMATION FOR DETAILS OF THE H&S RISKS AND HOW THESE HAVE BEEN REDUCED/ELIMINATED DURING THE DESIGN PROCESS. KEY RESIDUAL RISKS THAT HAVE NOT BEEN ELIMINATED ARE RECORDED IN THE H&S TABLE AND HIGHLIGHTED ON THIS DRAWING
 - 11) THE ABNORMAL LOAD CAPACITY OF THE STRUCTURE BASED ON THE DRAWING INFORMATION IS:
 - ABLE TO SUSTAIN THE SV196 WITH ASSOCIATED LM1 LOADING IN ADJACENT LANES
 - ABLE TO SUSTAIN THE SOV350 WITH ASSOCIATED LM1 LOADING IN ADJACENT LANES

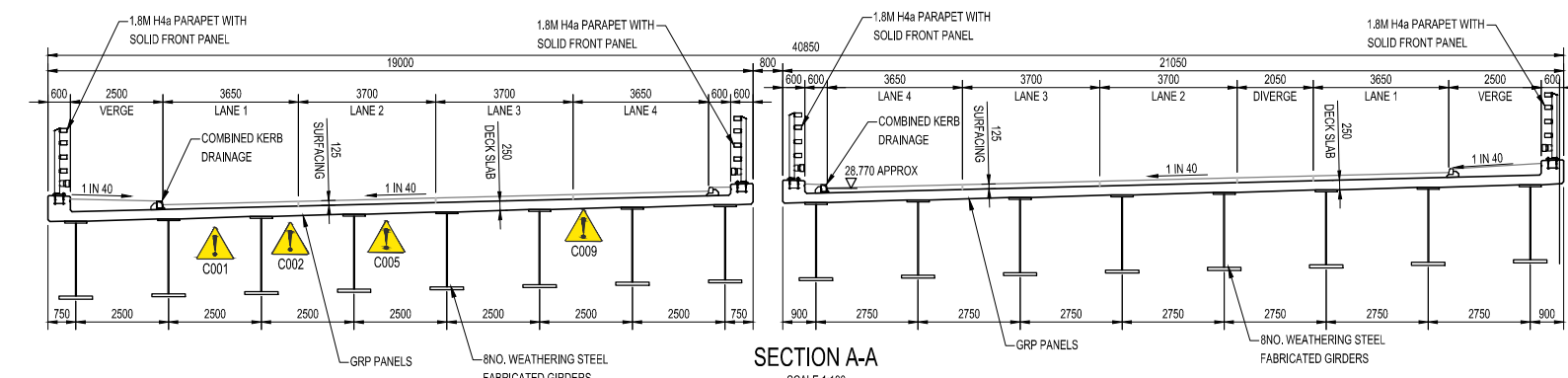

SECTION A-A
SCALE 1:100

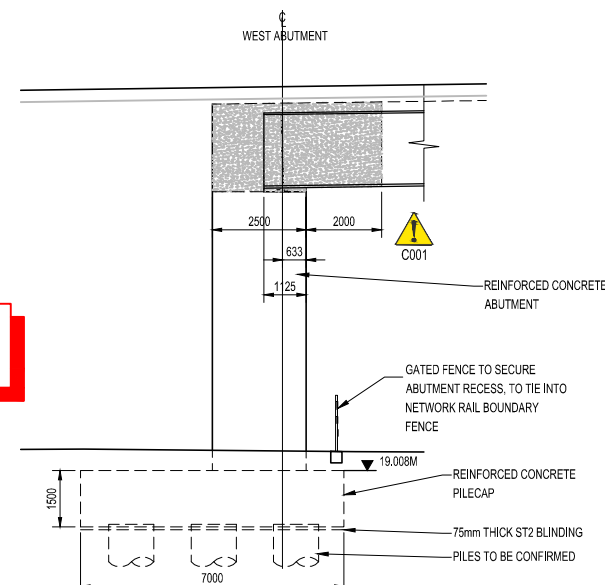

SECTION B-B
SCALE 1:100

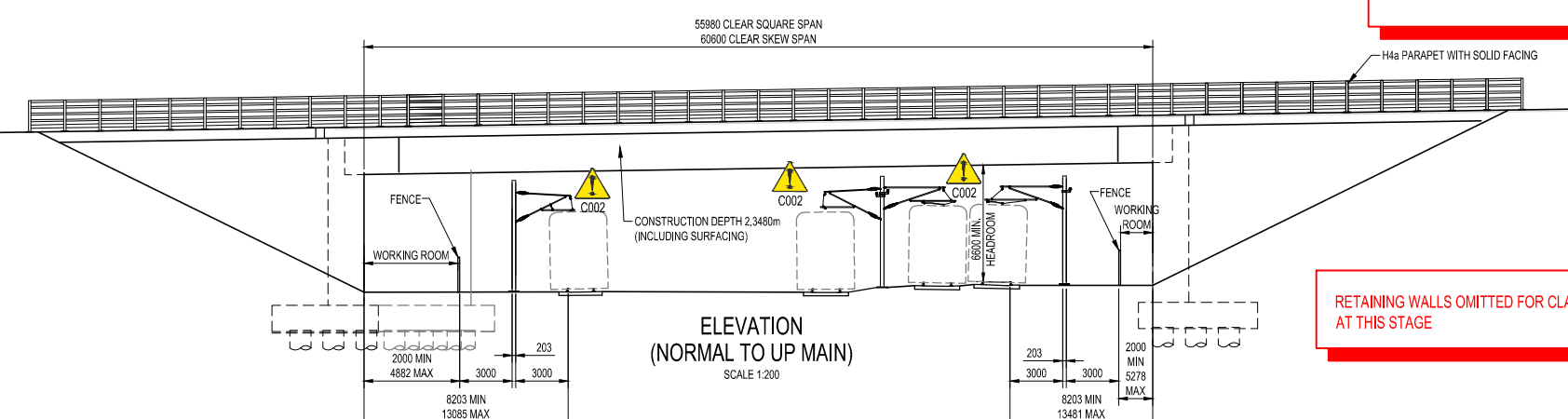

ELEVATION (NORMAL TO UP MAIN)
SCALE 1:200

BRACING OMITTED FOR CLARITY AT THIS STAGE

RETAINING WALLS OMITTED FOR CLARITY AT THIS STAGE

SAFETY, HEALTH AND ENVIRONMENTAL INFORMATION

IN ADDITION TO THE HAZARD RISKS NORMALLY ASSOCIATED WITH THE TYPES OF WORK DETAILED ON THIS DRAWING, NOTE THE FOLLOWING SIGNIFICANT RESIDUAL RISKS:

CONSTRUCTION	REF CODE - WORKING AT HEIGHT	REF CODE - PERSONNEL AND PLANT ENCODING THE L&R RAILWAY	REF CODE - HEAVY LIFTING - STEEL GIRDERS	REF CODE - STABILITY OF GRP DECK PLANS

SAFETY, HEALTH AND ENVIRONMENTAL SYMBOL LEGEND

Symbol	Description
	INDICATES A RESIDUAL RISK AS A WARNING

Rev.	Date	Description	By	Chk'd	App'd
P01.1	05/05/17				

WSP Three White Rose Office Park, Millshaw Park Lane, Leeds, LS11 0DL. Tel: +44 (0)113 395 6200

PARSONS BRINCKERHOFF

© WSP UK Ltd www.wsp-pb.com

Client: **Working on behalf of highways england**

Project Title: **A1 BIRTLEY TO COALHOUSE**

Drawing Title: **ALLERDENE OFFLINE REPLACEMENT SINGLE SPAN INTEGRAL BRIDGE GENERAL ARRANGEMENT GIRDER DEPTH 2.1M**

Scale	Drawn	Checked	Approved	Authorised
AS SHOWN	---	---	---	---

Original Size	Date	Date	Date	Date
A1	---	---	---	---

Drawing Status: Initial Status or WIP

Project Number: HE551462	Originator: WSP	Volume: SBR	Project Ref. No.
Location: BCH	Type: DR	Role: S	Revision: P01.1
	Number: 00028		

Appendix N-2

**INTEGRAL BRIDGE OPTION (B) – GIRDER DEPTH
2.1M**

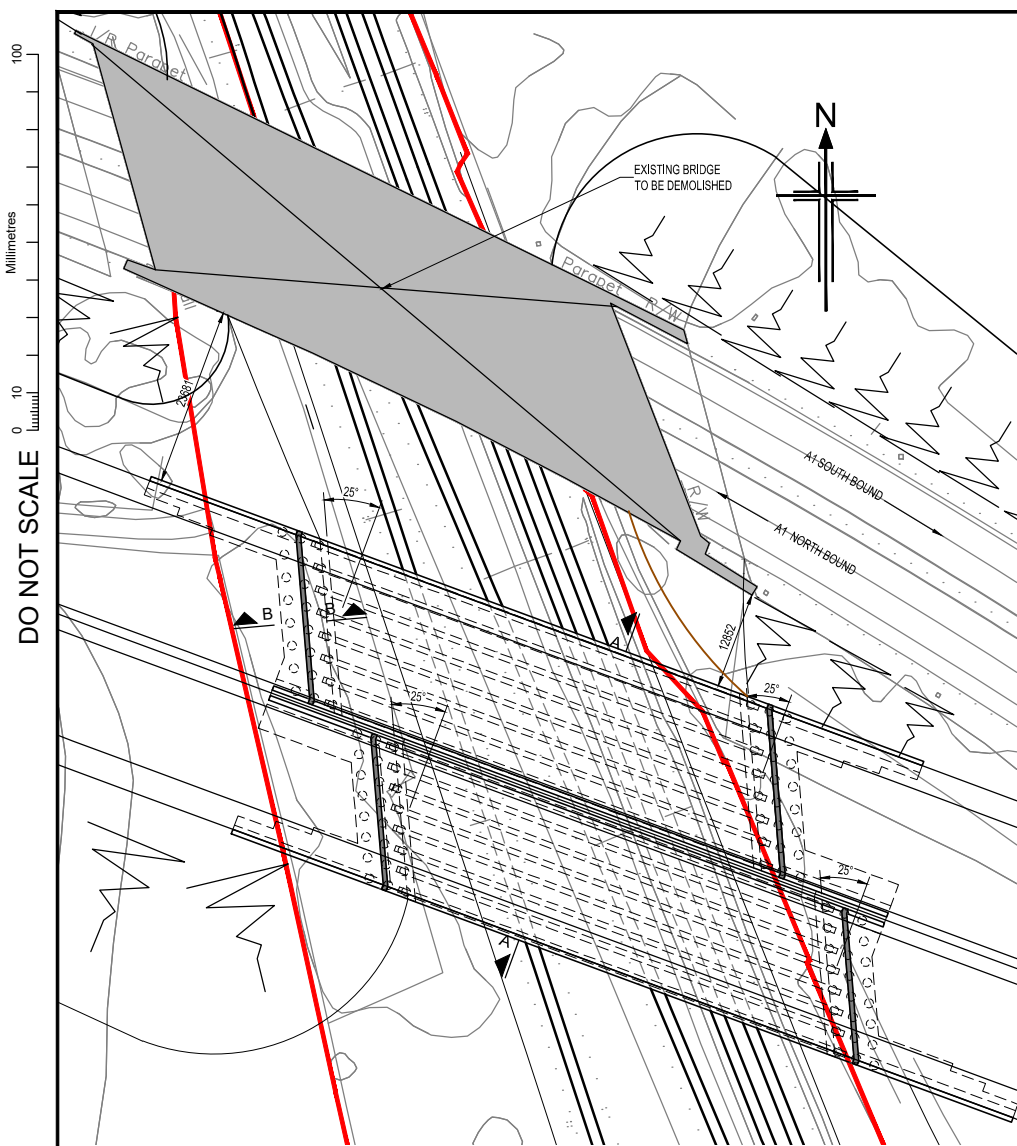

DO NOT SCALE

Millimetres
0 10 100

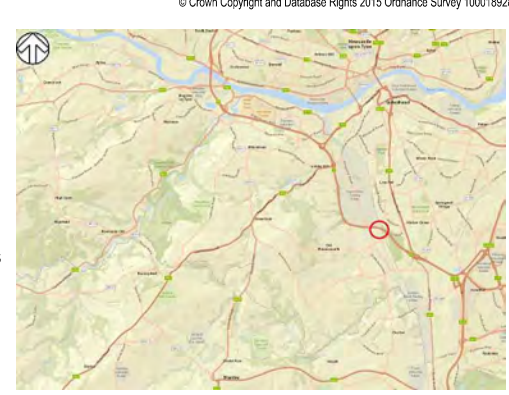
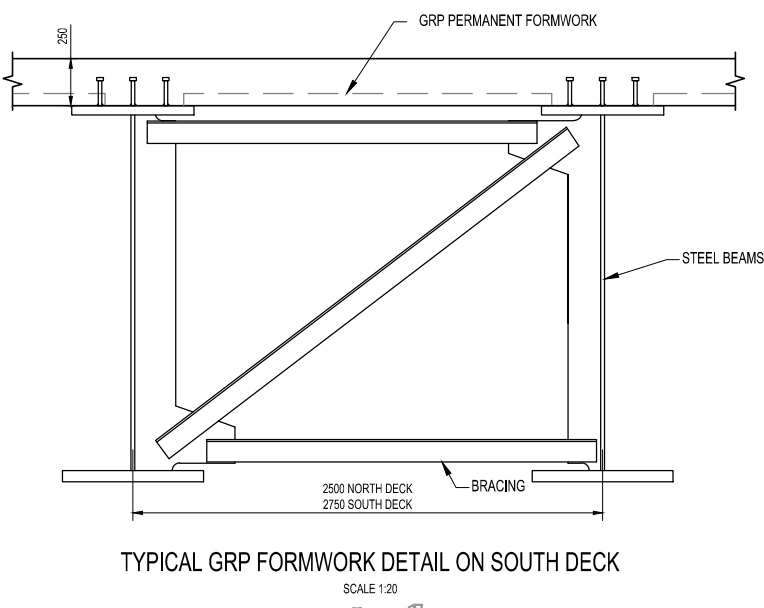
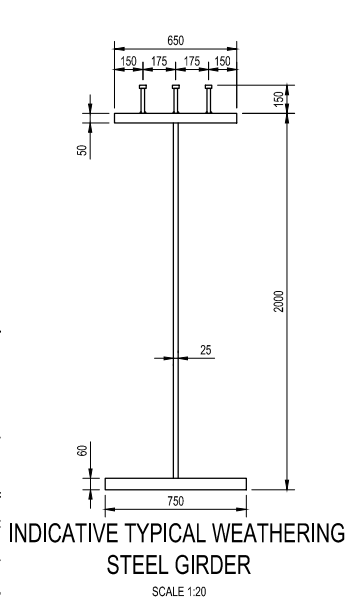

KEY PLAN
SCALE 1:5000

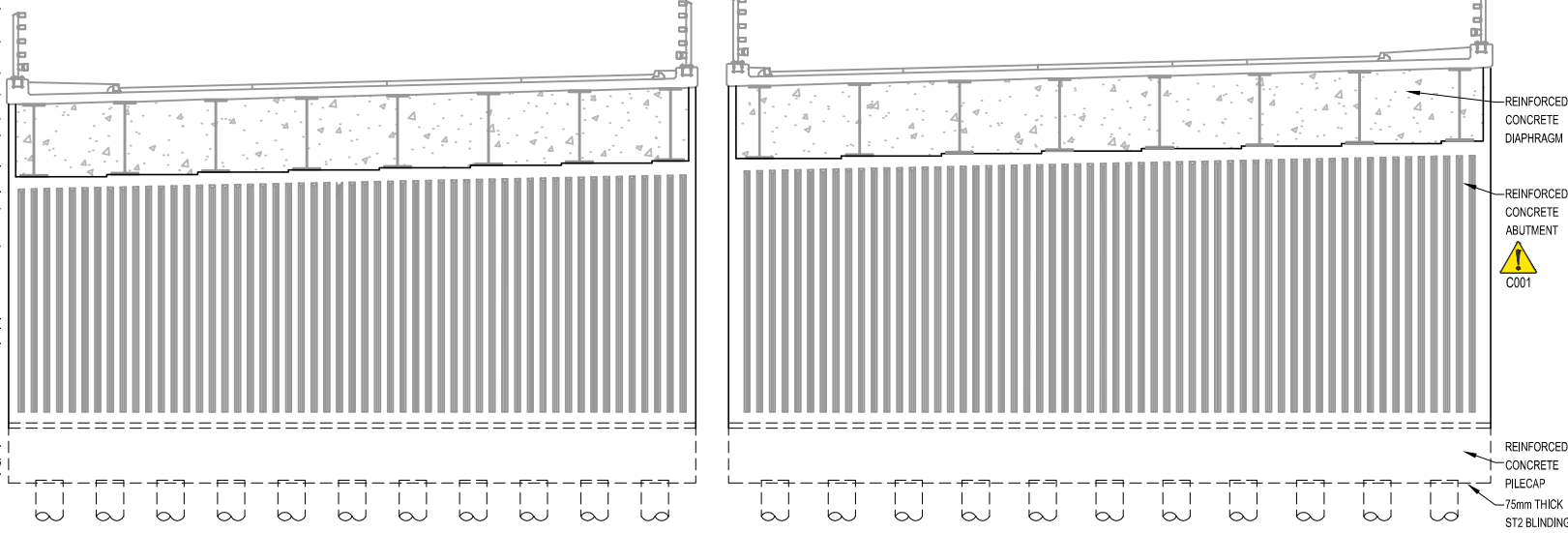

TYPICAL ABUTMENT ELEVATION
SCALE 1:100

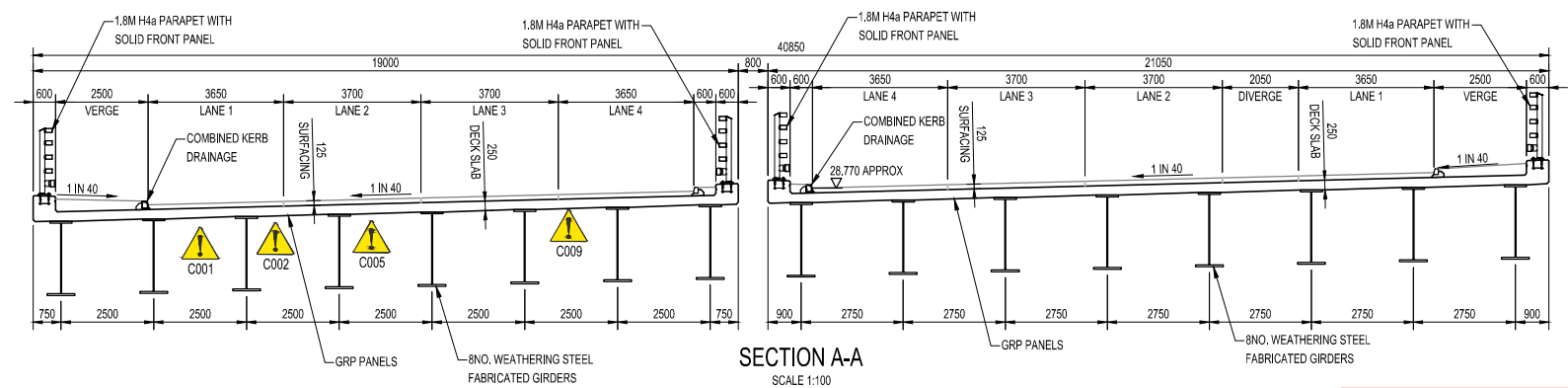

SECTION A-A
SCALE 1:100

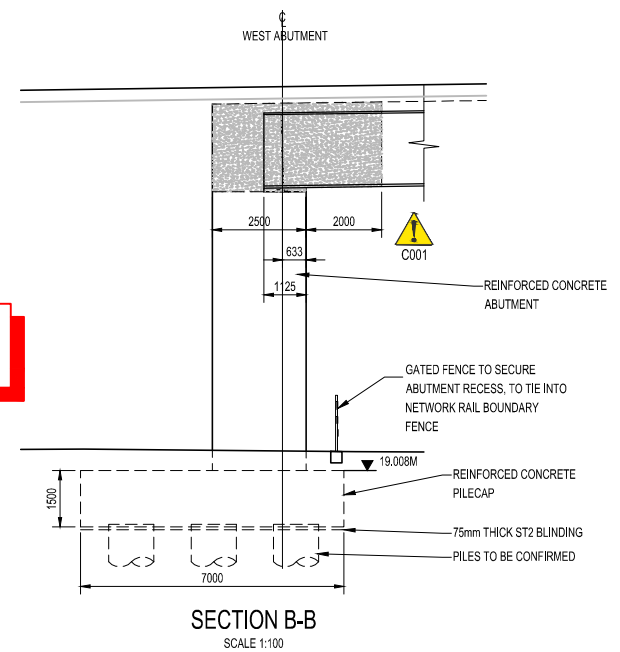

SECTION B-B
SCALE 1:100

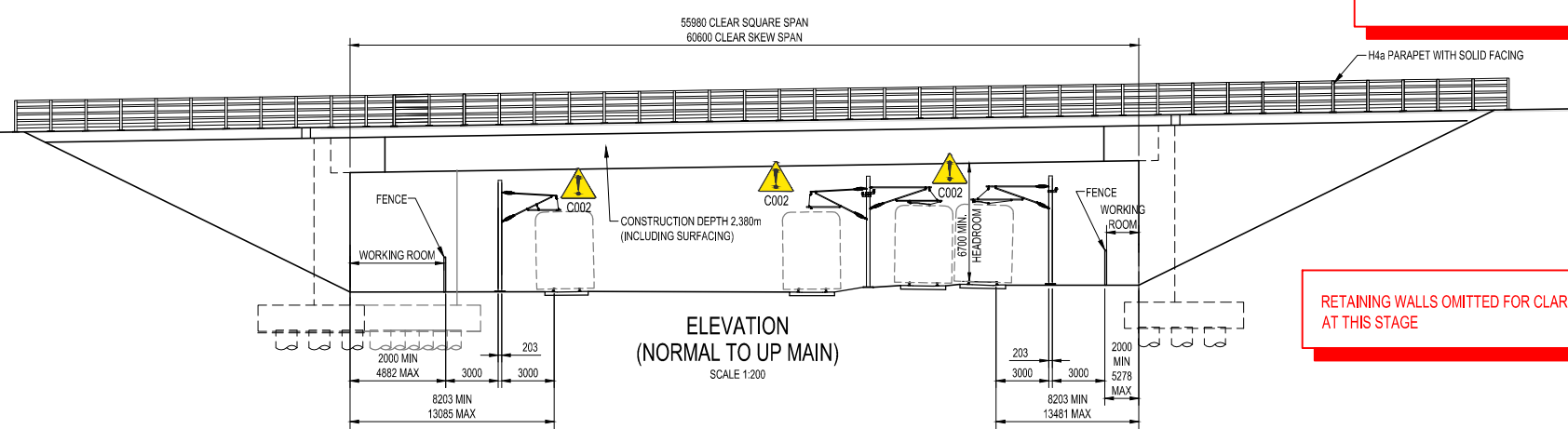

ELEVATION
(NORMAL TO UP MAIN)
SCALE 1:200

BRACING OMITTED FOR CLARITY AT THIS STAGE

RETAINING WALLS OMITTED FOR CLARITY AT THIS STAGE

- NOTES
- INTEGRAL BRIDGE DETAILS SHOWN ARE BASED ON PRELIMINARY DESIGN CALCULATIONS. DETAILS SHALL BE FINALISED BASED ON COMPLETION OF THE DETAILED DESIGN AND CAT III CHECK
 - ALL DIMENSIONS ARE IN MM UNLESS STATED OTHERWISE
 - ALL LEVELS ARE IN METRES UNLESS STATED OTHERWISE
 - DO NOT SCALE IN CASE OF ANY DOUBTS, OMISSIONS OR ERRORS SEEK CLARIFICATION FROM THE DESIGNER
 - THE BRIDGE SHALL BE CONSTRUCTED IN ACCORDANCE WITH THE RELEVANT DRAWINGS AND SPECIFICATION FOR HIGHWAY WORKS (SHW)
 - THE DESIGN OF ALL OLE WORKS TO BE ACCOMMODATED ARE DETAILED IN THE ALLERDENE RAILWAY BRIDGE OLE GRIP 3 REPORT
 - THE CONTRACTOR SHALL BE RESPONSIBLE FOR THE DIVERSION OF ALL SERVICES IMPACTING THE WORKS. DETAIL OF SERVICES ARE SHOWN ON THE SERVICES INFORMATION DRAWINGS AND APPENDIX 1/16 OF THE SHW
 - THE CONTRACTOR IS RESPONSIBLE FOR ALL TEMPORARY WORKS DESIGN AND INSTALLATION TO FACILITATE THE PERMANENT WORKS
 - THE CONTRACTOR'S ATTENTION IS DRAWN TO THE FOLLOWING MWR CONSTRAINTS TO BE MAINTAINED DURING THE WORKS
 - THE MINIMUM VERTICAL CLEARANCE FROM THE TOP OF THE RAIL TO THE DECK SOFFIT IS 6.7M
 - THE MINIMUM LATERAL CLEARANCE FROM THE RUNNING LINE TO THE PROVISION OF OLE MASTS IS 3.0M
 - THE MINIMUM SAFETY ZONE TO BE MAINTAINED FROM THE OLE MAST AND THE FENCE LINE (BEHIND WHICH THE BRIDGE SHALL BE CONSTRUCTED) IS 3.0M
 - THE MINIMUM LATERAL CLEARANCE BETWEEN THE RUNNING LINE AND THE FACE OF THE BRIDGE ABUTMENTS IN THE PERMANENT CONDITION IS 4.5M
 - THE CONTRACTOR SHALL REFER TO THE PRE CONSTRUCTION H&S INFORMATION FOR DETAILS OF THE H&S RISKS AND HOW THESE HAVE BEEN REDUCED/ELIMINATED DURING THE DESIGN PROCESS. KEY RESIDUAL RISKS THAT HAVE NOT BEEN ELIMINATED ARE RECORDED IN THE H&S TABLE AND HIGHLIGHTED ON THIS DRAWING
 - THE ABNORMAL LOAD CAPACITY OF THE STRUCTURE BASED ON THE DRAWING INFORMATION IS:
 - ABLE TO SUSTAIN THE SV196 WITH ASSOCIATED LM1 LOADING IN ADJACENT LANES
 - ABLE TO SUSTAIN THE SOV 350 ALONE WHEN TRAVELING CENTRALLY OVER THE BRIDGE (LANE 2/3)

SAFETY, HEALTH AND ENVIRONMENTAL INFORMATION

IN ADDITION TO THE HAZARD RISKS NORMALLY ASSOCIATED WITH THE TYPES OF WORK DETAILED ON THIS DRAWING, NOTE THE FOLLOWING SIGNIFICANT RESIDUAL RISKS:

CONSTRUCTION	REF CODE - WORKING AT HEIGHT	REF CODE - PERSONNEL AND PLANT ENCODING THE L&R RAILWAY	REF CODE - HEAVY LIFTING - STEEL GIRDERS	REF CODE - STABILITY OF GRP DECK PLANS

SAFETY, HEALTH AND ENVIRONMENTAL SYMBOL LEGEND

INDICATES A RESIDUAL RISK AS A WARNING

Rev.	Date	Description	By	CHK'd	App'd
P01.1	05/05/17				

WSP
PARSONS BRINCKERHOFF

Three White Rose Office Park,
Millshaw Park Lane,
Leeds,
LS11 0DL
Tel: +44 (0)113 395 6200

© WSP UK Ltd www.wsp-pb.com

Client
Working on behalf of
highways england

Project Title
A1 BIRTLEY TO COALHOUSE

Drawing Title
**ALLERDENE OFFLINE REPLACEMENT
SINGLE SPAN INTEGRAL BRIDGE
GENERAL ARRANGEMENT
GIRDER DEPTH 2.0M**

Scale	Drawn	Checked	Approved	Authorised
AS SHOWN	---	---	---	---

Original Size	Date	Date	Date	Date
A1	---	---	---	---

Drawing Status: Initial Status or WIP Suitability: S0

Drawing Number	Project	Originator	Volume	Project Ref. No.
HE551462	BCH	WSP	SBR	
		DR	S	00029
		Type	Role	Number

Revision: P01.1

Appendix O

EXISTING ALLERDENE BRIDGE – MAINTENANCE EXPENDITURE

Appendix O-1

ALLERDENE BRIDGE MAINTENANCE EXPEDITURE

Appendix O-2

**INTEGRAL BRIDGE OPTION (B) – GIRDER DEPTH
2.1M**



Appendix P

KEY CORRESPONDENCE

Appendix P-1

CLOSE OUT COMMENTS BETWEEN HE / WSP

Brunetti Barchetta, Giovanna

From: Sunderland, Martin <Martin.Sunderland@highwaysengland.co.uk>
Sent: 02 June 2017 15:40
To: Mistry, Hitan
Cc: Al-Shalechy, Shehed; Mulla, Imtiaz; Rawcliffe, Nigel; Wilkes, Nicola; Littlewood, James; Dennis, Stephen; Mehta, Rakesh; Jariwala, Mohammad Ibrahim
Subject: RE: A1B2CH: Structures : Submission of SOR for Allerdene Bridge Replacement 09-05-17

Dear Hitan

Thank you for the SOR for the Allerdene Railway Bridge: Replacement Study which was delivered to our offices on the 09/05/2017.

The report has been commissioned as part of the proposed upgrade of the A1 between J65 Birtley and J67 Coalhouse.

The report outlines the aims of the scheme, and the many challenges and constraints for either the modification of the existing Allerdene Bridge, or its demolition and reconstruction of a new structure either “on line” or “off line”.

The main challenges and constraints highlighted by the report are:

- The existing Allerdene Bridge is situated on the A1 just South of J67, and carries the A1 as a dual two lane road over the East Coast mainline, the existing bridge form is of complex multi-span construction containing half joints, and poses many challenges for its maintenance over this very important length of Network Rail infrastructure.
- That one of the main objectives of the scheme to meet operational requirements is to improve the existing highway at this location to a dual three lane rural all-purpose road, and it is accepted that it is not practicable to widen the existing bridge to accommodate the requirements of the proposed three lane highway.
- Network rail requirements for increased headroom at a new structure to suit modern Overhead Line Equipment (OLE), and this substantial increase in headroom rules out to some extent the “hybrid” option, which is also further ruled out by buildability issues around reuse of the existing sub-structure.

Taking into account the above and other issues detailed in the report I confirm agreement with the recommendations of the report that the off-line replacement be further developed.

Please accept this email communication on behalf of Highways England as confirmation of our acceptance of the report and its conclusions and recommendations.

Have a good weekend.

Regards

**Martin Sunderland, Senior Structures Advisor
Safety, Engineering and Standards**

Highways England | Lateral | 8 City Walk | Leeds | LS11 9AT

TEL 0300 470 6165

Web: <http://www.highways.gov.uk>



If you need help accessing this or any other Highways England information, please call **0300 470 4580** and we will help you.

© Crown copyright 2019.

You may re-use this information (not including logos) free of charge in any format or medium, under the terms of the Open Government Licence. To view this licence:

visit www.nationalarchives.gov.uk/doc/open-government-licence/

write to the Information Policy Team, The National Archives,

Kew, London TW9 4DU, or email

psi@nationalarchives.gsi.gov.uk.

This document is also available on our website at www.gov.uk/highways

If you have any enquiries about this document A1BirtleytoCoalhouse@highwaysengland.co.uk or call 0300 470 4580*.

*Calls to 03 numbers cost no more than a national rate call to an 01 or 02 number and must count towards any inclusive minutes in the same way as 01 and 02 calls.

These rules apply to calls from any type of line including mobile, BT, other fixed line or payphone. Calls may be recorded or monitored.

Registered office Bridge House, 1 Walnut Tree Close, Guildford GU1 4LZ
Highways England Company Limited registered in England and Wales number 09346363